

LODES

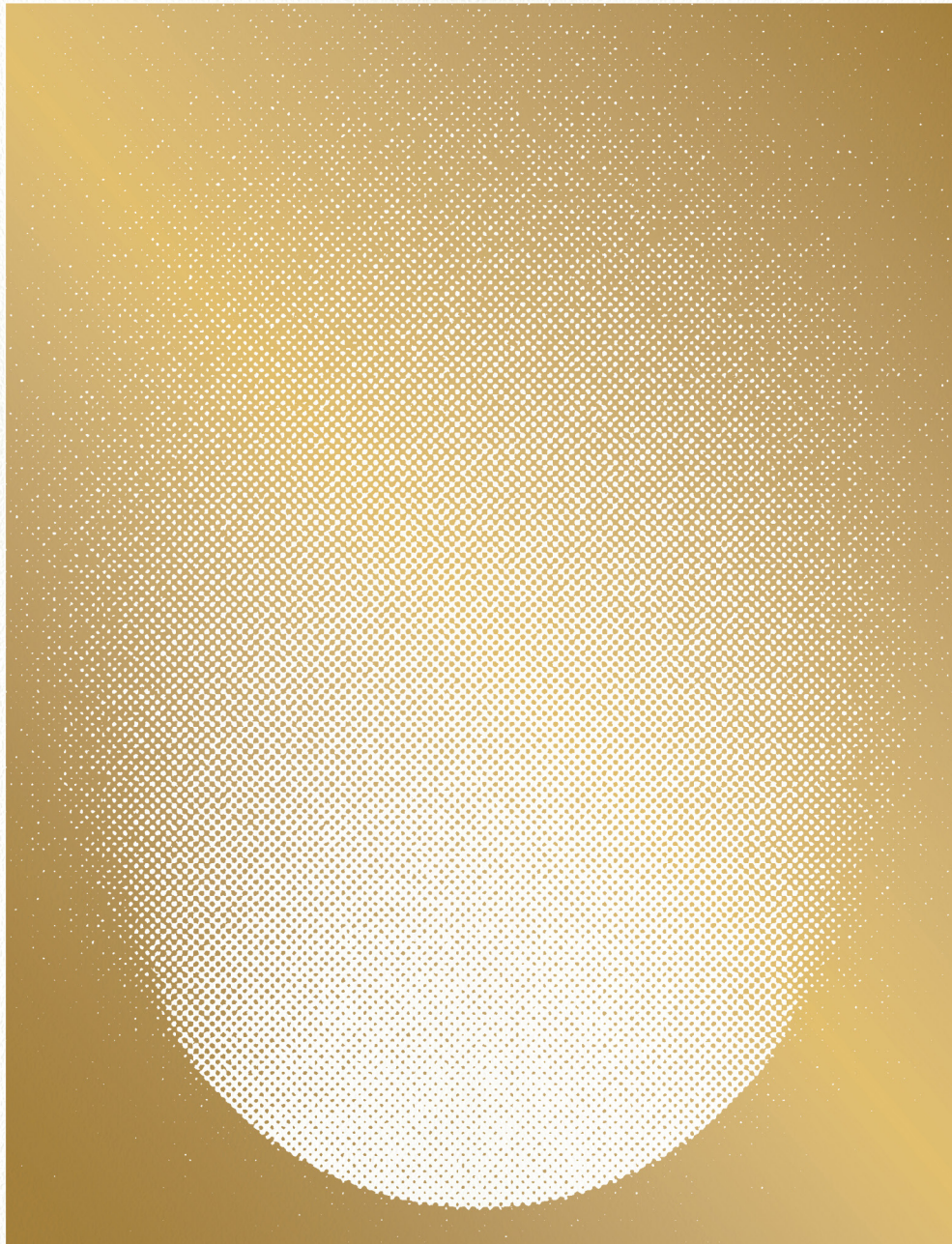

P.	PRODUCT NAME	CATEGORY
312	A Aile	Wall lamp
232	A-Tube	Cluster suspension lamp, Ceiling lamp
204	A-Tube Nano	Cluster suspension lamp
222	A-Tube Nano Duo	Cluster suspension lamp
380	B Blow	Table lamp
348	Bugia	Ceiling lamp
414	C Cima	Suspension lamp, Floor lamp
074	Cono di Luce	Suspension lamp, Table lamp
394	Croma	Floor lamp
386	E Easy Peasy	Cordless table lamp
034	Elara	Suspension lamp
404	F Flar	Table lamp, Floor lamp
370	H Hover	Table lamp, Floor lamp
176	I IVY I	Cluster suspension lamp
176	IVY V	Suspension lamp, Central cluster suspension lamp
166	J Jefferson	Cluster suspension lamp
192	JIM	Cluster suspension lamp, Suspension lamp
060	K Kelly	Suspension lamp, Wall lamp
270	Kelly Cluster	Cluster suspension lamp
362	L Laser	Wall lamp
292	N Nautilus	Ceiling lamp, Wall lamp
292	Nautilus Mini	Wall lamp
150	Nostalgia	Cluster suspension lamp
356	P Pin-Up	Wall lamp, Ceiling lamp
328	Puzzle	Wall lamp, Ceiling lamp
334	Puzzle Mega	Wall lamp, Ceiling lamp
318	Puzzle Round	Wall lamp, Ceiling lamp
242	R Rain	Cluster suspension lamp
110	Random	Cluster suspension lamp
020	Random Cloud	Suspension lamp
130	Random Solo	Cluster suspension lamp
046	S Sky-Fall	Suspension lamp
254	Spider	Cluster suspension lamp, Ceiling lamp
282	T Tidal	Ceiling lamp
088	V Volum	Cluster suspension lamp, Suspension lamp, Wall lamp, Ceiling lamp, Table lamp

ED. 2024 Collection Catalogue

1

LODES



2

Lodes designs and manufactures lighting solutions for both indoor and outdoor spaces. We design and manufacture light sources that enhance the quality of living for those who choose them in any environment and situation. We seek a balance between form and functionality to elevate every space with a distinctive decorative touch, without compromising on design or utility.

Lodes progetta e produce soluzioni illuminotecniche per arredare spazi interni ed esterni. Immaginiamo e realizziamo sorgenti luminose che migliorino la qualità dell'abitare di chi le sceglie, in qualsiasi ambiente e situazione. Cerchiamo l'equilibrio tra forma e funzionalità per valorizzare ogni spazio con un segno decorativo distintivo, senza compromessi né rinunce.

“For our *family*, light is a 70-year legacy.”

In Venice since 1950

Founded in 1950, *Lodes* narrates an evolutionary journey through three generations, from a pure passion for light to contemporary creations that seamlessly blend design and technological innovation. Our products are designed for optimal enjoyment of living spaces, emphasising ease of installation, immediate interaction, and energy efficiency. *Lodes* ensures quality throughout the supply chain, from material selection to production techniques, deliveries, and post-sales service. The company's transformation includes a significant rebranding initiative initiated in 2020. This cultural shift, stemming from the aspiration to explore new avenues and the commitment to continual learning from light, centres on research, design, and innovation to develop progressively versatile and innovative lighting solutions. Today, *Lodes* stands as one of Europe's foremost manufacturers of decorative lighting, operating in over 90 global markets.

A Venezia dal 1950

Nata nel 1950 dalla passione per il vetro del fondatore, *Lodes* racconta un percorso evolutivo attraverso tre generazioni, dalla pura passione per la luce alle creazioni contemporanee che coniugano design e ricerca tecnologica. I nostri prodotti sono pensati per godere appieno degli spazi di vita – facili da installare, immediati nell'interazione ed efficienti nei consumi – e realizzati attraverso una filiera controllata dalla scelta dei materiali e delle migliori tecniche di produzione, fino alle consegne e al servizio post-vendita. L'evoluzione dell'azienda passa anche attraverso un'importante fase di rebranding iniziata nel 2020. Questa rivoluzione culturale, nata dal desiderio di esplorare nuovi sentieri, dalla voglia di rinnovarsi e di continuare a studiare e a imparare dalla luce, mette al centro la ricerca, la progettazione e l'innovazione per creare soluzioni illuminotecniche sempre più versatili e innovative. Oggi *Lodes* è uno dei principali produttori europei di illuminazione decorativa, attiva in oltre 90 mercati di tutto il mondo.





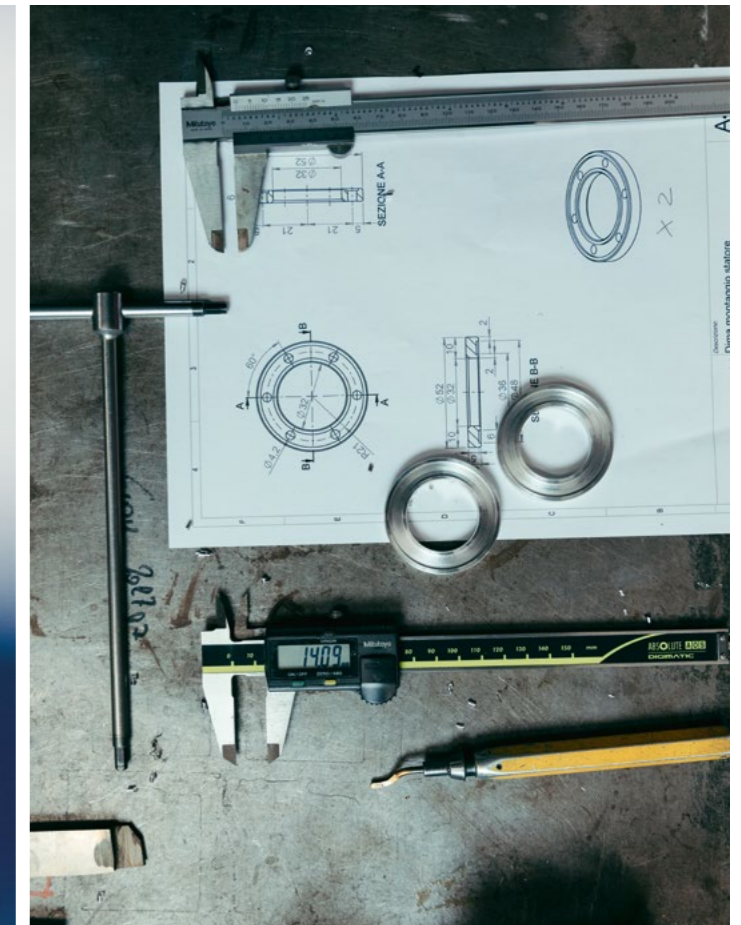













3

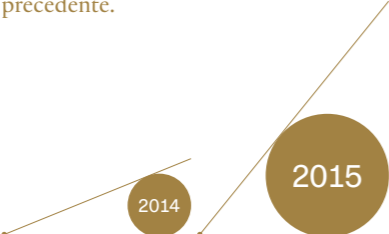

4

Lodes Timeline 1950–Today

<p>1950 Angelo Tosetto, Fabbrica di Lampadari was founded. ● Viene fondata la Angelo Tosetto, Fabbrica di Lampadari.</p> 	<p>2013 Massimiliano Tosetto is appointed General Manager of the company. ● Massimiliano Tosetto è nominato Direttore Generale di Studio Italia Design.</p>  <p>Massimiliano Tosetto</p>	<p>2019/2021 The partnership with designer <i>Luca Nichetto</i> resulted in products such as <i>Jefferson</i> and <i>Croma</i>. ● La collaborazione con il designer <i>Luca Nichetto</i> dà origine a prodotti quali <i>Jefferson</i> e <i>Croma</i>.</p>	<p>2022 Lodes announces its first collaboration with international architecture and design studio, <i>Snohetta</i>. The partnership sees the launch of a new lighting collection entitled <i>Volum</i>. ● Lodes annuncia la sua prima collaborazione con lo studio internazionale di architettura e design <i>Snohetta</i>. Il frutto di questa sinergia è la nuova collezione <i>Volum</i>.</p>  <p>Volum, design by Snohetta, 2022</p>	<p>2022 Lodes presents <i>Elara</i> and <i>Hover</i>. ● Lodes presenta <i>Elara</i> e <i>Hover</i>.</p>  <p>Elara, design by Nika Zupanc, 2022 Hover, design by YOY, 2022</p>	<p>2023 <i>Volum</i> table, Archiproducts Design Awards 2023.</p>  <p>archiproducts DESIGN AWARDS</p>
<p>1985 Angelo's three children take over the company and change its name to Tre-T Lighting. ● I tre figli di Angelo Tosetto rilevano l'azienda e cambiano il nome in Tre-T Illuminazione.</p>	<p>2014 The company develops proprietary AC-line voltage LED modules. ● L'azienda sviluppa moduli LED proprietari a tensione di rete.</p> 	<p>2020, 2021 <i>Easy Peasy</i> and <i>Cima</i>, two new Lodes collections debut in the spirit of the relationship between light and space. ● <i>Easy Peasy</i> e <i>Cima</i>, debuttano due nuove collezioni Lodes nel segno delle relazioni tra luce e spazio.</p>  <p>Easy Peasy, design by Luca Nichetto, 2020 Cima, design by Marco Dessi, 2021</p>	<p>2022 Lodes presents <i>Flar</i> and <i>IVY</i>, two new collections that tell of the relationship between light, space and people. ● Lodes presenta <i>Flar</i> e <i>IVY</i>, due nuove collezioni che raccontano della relazione tra la luce, lo spazio e le persone.</p>  <p>Flar, design by Patrick Norguet, 2022 IVY I and V, design by Vittorio Massimo, 2022</p>	<p>2023 Lodes presents <i>Tidal</i> and the extension of the <i>Volum</i> collection. ● Lodes presenta <i>Tidal</i> e l'estensione della famiglia <i>Volum</i>.</p>  <p>Tidal, design by Needs Studio, 2023 Volum, design by Snohetta, 2023</p>	<p>2023 <i>Hover</i> lamp by YOY has been shortlisted for the Dezeen Awards 2023.</p>  <p>dezeen awards 2023</p>
<p>1997 Andrea Tosetto, one of the three siblings, takes over the company, renames it Studio Italia Design, and transfers the headquarters to Marcon. Andrea embraces a more contemporary language, and transitions to digital design. ● Andrea Tosetto, uno dei tre fratelli, assume il comando dell'azienda, cambia nome in Studio Italia Design e trasferisce la sede a Marcon. Andrea predilige uno stile più contemporaneo e introduce la progettazione digitale.</p>  <p>Andrea Tosetto</p>	<p>2015 The <i>Kelly</i> suspension lamp by <i>Andrea Tosetto</i> is added to the catalogue. ● La lampada a sospensione <i>Kelly</i> disegnata da <i>Andrea Tosetto</i> entra in catalogo.</p>  <p>Kelly, design by Andrea Tosetto, 2015</p>	<p>2021 The Diesel Living with Lodes line makes its debut to mark the global exclusive collaboration between Diesel and Lodes. ● Debutta la linea Diesel Living with Lodes, frutto dell'esclusiva collaborazione globale tra Diesel e Lodes.</p> 	<p>2022 <i>Flar</i>, Archiproducts Design Awards 2022.</p>  <p>archiproducts DESIGN AWARDS 2022</p>	<p>2023 Lodes announces strategic expansion in <i>North America</i> – new branch in <i>New York</i>. ● Lodes annuncia l'espansione strategica in <i>Nord America</i>: una nuova filiale a <i>New York</i>.</p>	<p>2024 The firm has been again selected as one of the most dynamic Italian companies according to the survey "Campioni della crescita 2024", published in La Repubblica's "Affari & Finanza". ● Lodes è stata nuovamente selezionata come una delle aziende italiane più dinamiche secondo l'indagine "Campioni della crescita 2024" pubblicata su "Affari & Finanza" de La Repubblica.</p>
<p>2004 Massimiliano Tosetto, Andrea's son, joins the company as Export Sales Manager. ● Massimiliano Tosetto, figlio di Andrea, entra in azienda come Responsabile commerciale estero.</p>	<p>2015 Turnover doubles vs the previous year. ● Raddoppio del fatturato rispetto all'anno precedente.</p> 	<p>2022 The Company saw an increase of +13% in terms of turnover. ● L'azienda ha visto un incremento del business pari al +13%.</p>	<p>2022 Lodes lands in <i>Milan</i>. The first Lodes' space in the world. ● Lodes arriva a <i>Milano</i>. Il primo spazio Lodes al mondo.</p> 	<p>2023 Lodes presents <i>Cono di Luce</i> in collaboration with <i>Ron Arad</i>. ● Lodes presenta <i>Cono di Luce</i> in collaborazione con <i>Ron Arad</i>.</p>  <p>Cono di Luce, design by Ron Arad, 2023</p>	<p>2024 The <i>flagship</i> spaces in <i>Paris</i> and <i>Cologne</i>, dedicated to professionals, customers & partners, promote moments of interaction and discussion on light and solutions designed by the company. ● Gli <i>spazi espositivi</i> a <i>Parigi</i> e <i>Colonia</i>, dedicati a clienti, partner e collaboratori, promuovono momenti di scambio e condivisione sulla luce e sulle soluzioni progettate dall'azienda.</p>

Mastery

Our choice materials are *glass* and *metal*, carefully shaped and crafted to meet the specific requirements of each project. *Mastery* represents the expertise accumulated through years of direct experience. The choice of using different materials and processing techniques that combine innovation and skills acquired over time allows *Lodes* to create enduring and meaningful lighting solutions.

5

Mestiere

Vetro e metallo sono i nostri materiali d'elezione, che plasmiamo e lavoriamo in funzione delle specifiche esigenze di ogni progetto. Il *Mestiere* è il saper fare consolidato attraverso l'esperienza diretta nel corso degli anni. La scelta di utilizzare materie diverse e tecniche di lavorazione che uniscono innovazione e abilità acquisite nel tempo consente a *Lodes* di creare soluzioni illuminotecniche durevoli e ricche di significato.

6

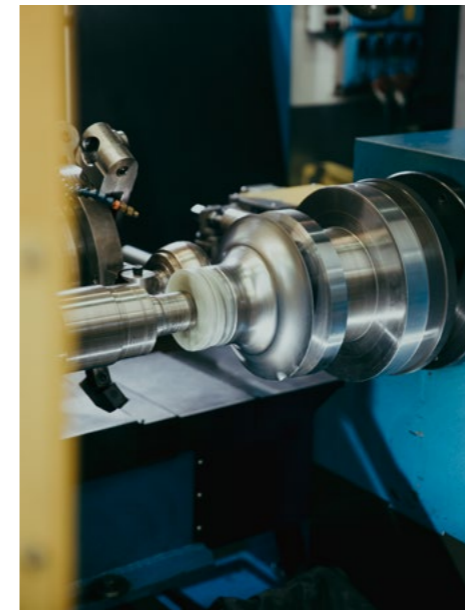

7

Metals are among the most resistant materials in the world. By combining skills perfected over the years and contemporary techniques, *Lodes* is able to shape them according to the specific needs of each project, giving life to luminous creations that blend design and durability over time.

8



I *metalli* sono tra i materiali più resistenti al mondo: unendo abilità perfezionate negli anni e tecniche contemporanee, *Lodes* riesce a plasmarli in funzione delle specifiche esigenze di ogni progetto per dar vita a creazioni luminose che coniugano design e resistenza nel tempo.



9

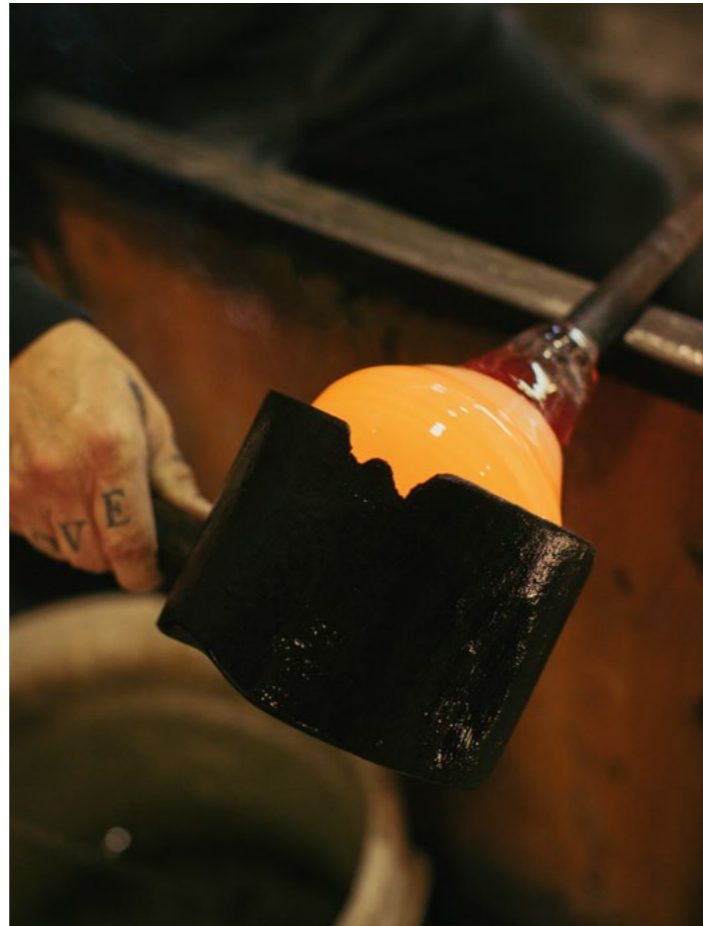

10



11

Blowing is an ancient *glassmaking* technique that finds one of its highest expressions in Venice, the territory of *Lodes*. The company's founder passed on the secrets learned from master glassblowers and the passion for this refined art to contemporary generations, who continue to use the age-old technique of glassblowing in many collections in the catalogue.

La *soffiatura* è un'antica tecnica di lavorazione del vetro che trova una delle sue alte espressioni proprio a Venezia, il territorio di *Lodes*. Il fondatore dell'azienda ha trasmesso i segreti appresi dai mastri vetrai e la passione per questa raffinata arte alle generazioni contemporanee, che continuano a utilizzare la millenaria tecnica della soffiatura in molte collezioni a catalogo.



12



13

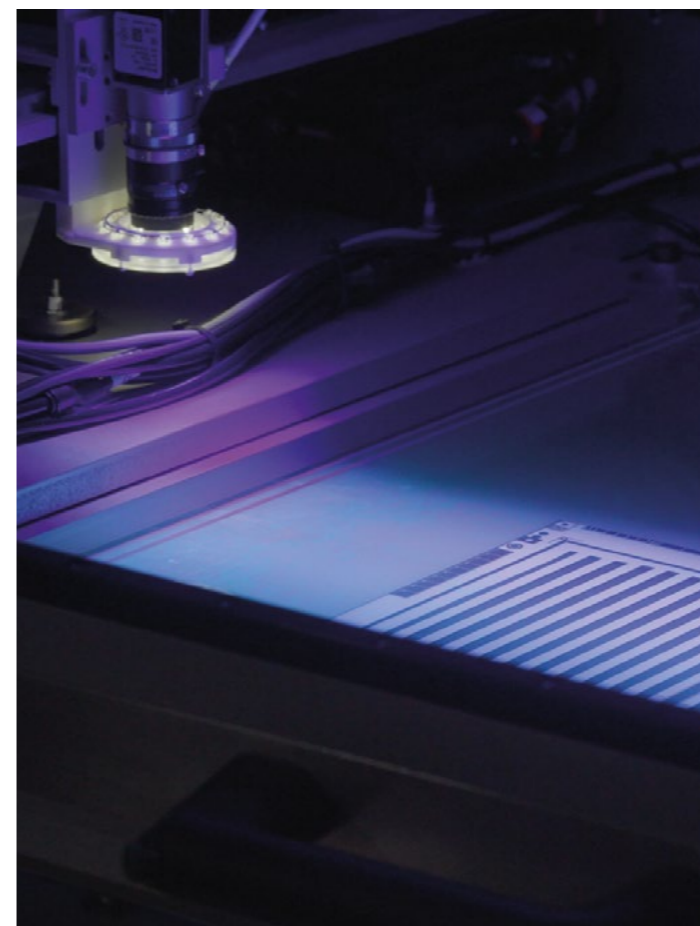

14

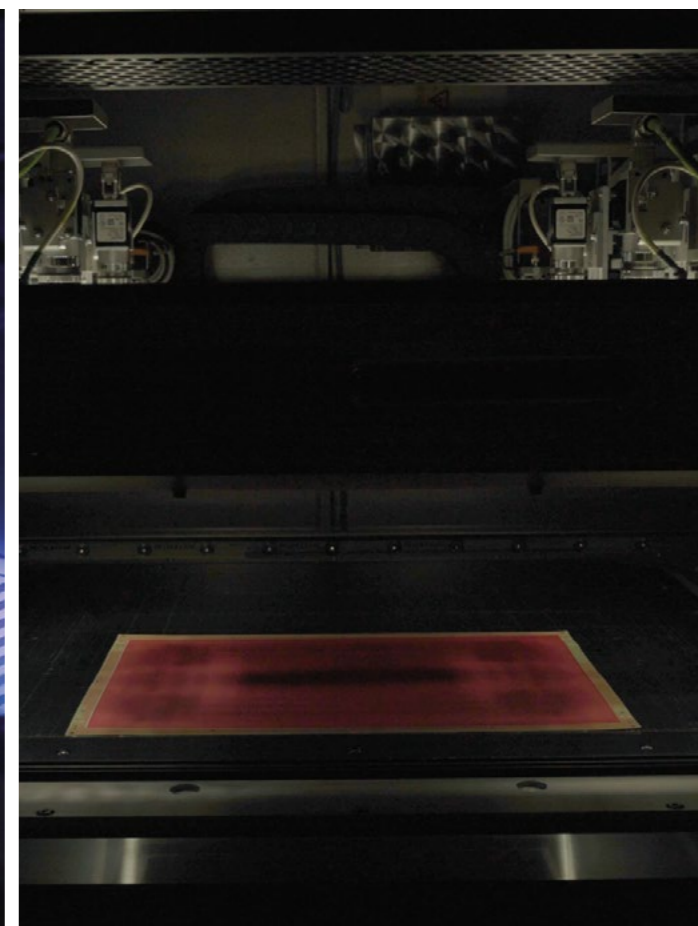

15



A thin, flexible, and insulating sheet of glass fibre forms the basis for a copper path serving as an electrical conductor for the LED. Thanks to its expressive and aesthetic properties, the *PCB* enables *Lodes* to create innovative designs that alternate between different reflections of light.

Un sottile foglio di fibra di vetro, flessibile e isolante, è la base per un path di rame che funge da conduttore elettrico per il LED. Grazie alle sue proprietà espressive ed estetiche, il *PCB* consente a *Lodes* di realizzare inedite creazioni che alternano diversi riflessi di luce.

Lodes designs and produces luminous innovation through its LED technology, meticulously crafting both mains voltage and low voltage LED modules to deliver light quality comparable to halogen bulbs. The efficiency inherent in our LED light sources leads to energy savings, extended lifespans, and reduced maintenance and replacement costs compared to traditional light sources.

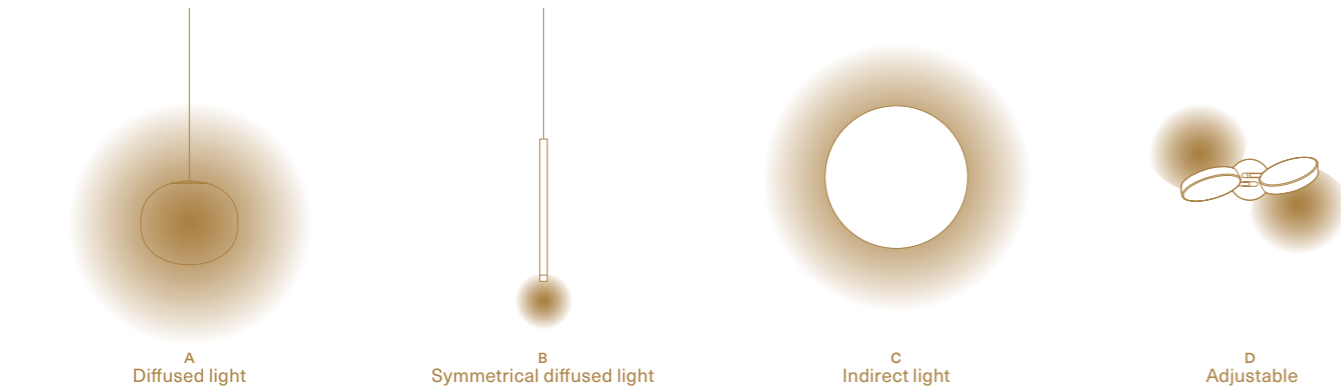

16

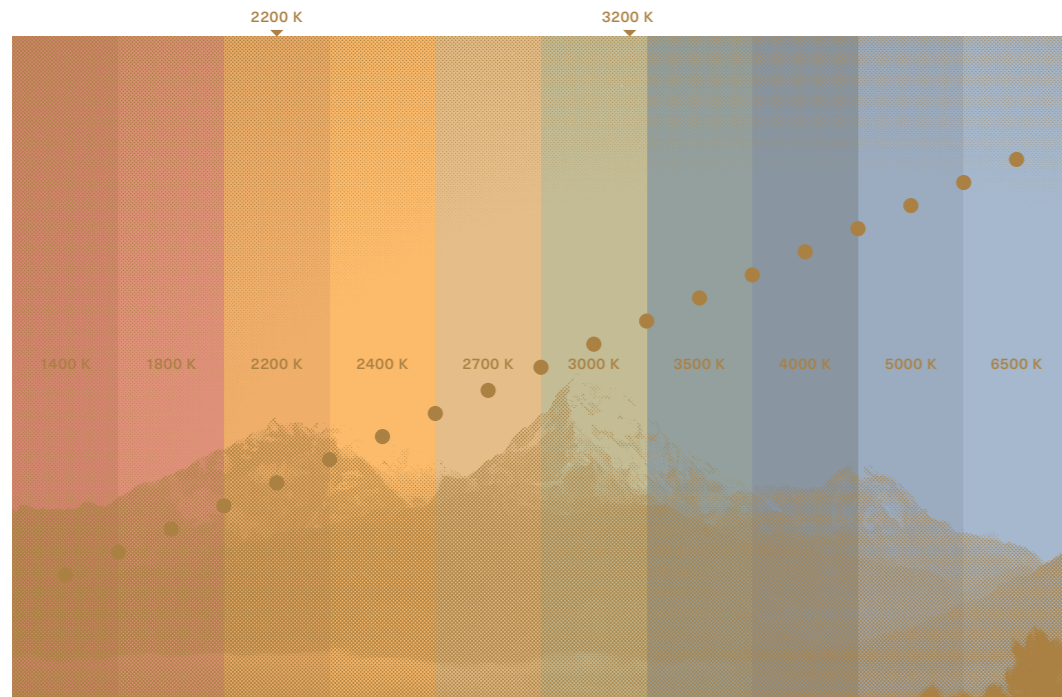

17

Lodes progetta e produce moduli LED a tensione di rete e a bassa tensione per fornire la stessa qualità di luce delle lampadine alogene. L'efficienza delle nostre sorgenti luminose a LED si traduce in risparmio energetico e lunga durata, con costi di manutenzione e di sostituzione inferiori rispetto alle fonti di luce tradizionali.

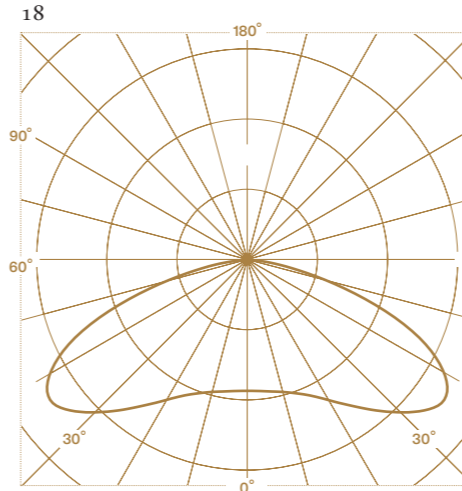
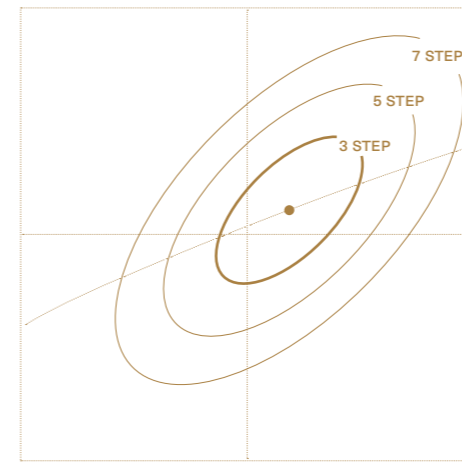

19

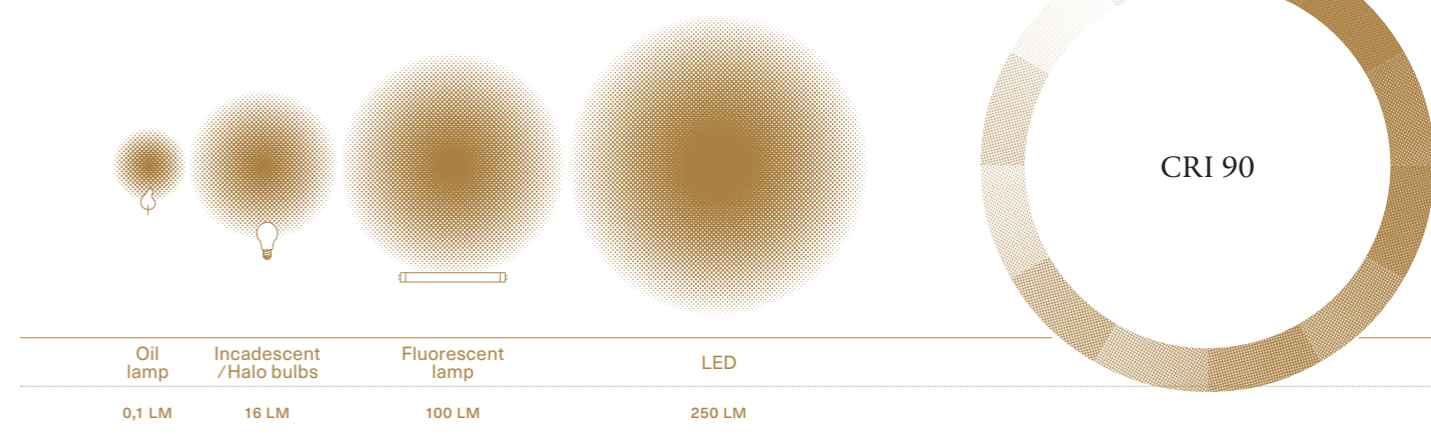

20

17. Our LEDs are engineered to fill spaces with a warm and emotionally resonant glow, ranging between 2700 K and 3000 K on the light colour temperature scale, measured in Kelvin degrees. This scale corresponds to the hue emitted by the light source.

18. All our LED sources ensure the same high-quality light colour. This uniformity allows different lamps to be seamlessly combined in a single room, with colour variations falling within the 3-step MacAdam ellipse, and therefore imperceptible to the human eye.

20. We design LED light sources with a CRI (Colour Rendering Index) of 90 or higher to authentically reproduce the natural colours of objects. The CRI quantifies a light source's ability to faithfully render colours.

17. Realizziamo LED che inondano gli ambienti con una luce calda ed emozionale – la temperatura del colore della luce è espressa in gradi Kelvin e corrisponde alla tonalità emessa dalla sorgente luminosa: i LED di Lodes hanno una temperatura tra i 2700 K e i 3000 K.

18. Tutte le nostre sorgenti LED forniscono la stessa qualità di colore della luce per combinare in un unico ambiente anche lampade diverse – le variazioni di colore rientrano nel 3°Step dell'ellisse di MacAdam e sono impercettibili all'occhio umano.

20. Sviluppiamo sorgenti luminose a LED con CRI uguale o superiore a 90 per restituire il colore naturale degli oggetti – il CRI (Colour Rendering Index) è il valore che misura la capacità di una sorgente luminosa di riprodurre fedelmente i colori di un oggetto.

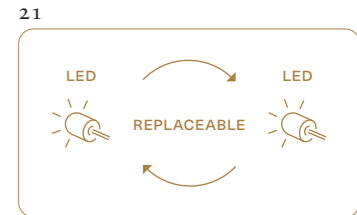

21

16 Type of light: diffused, symmetrical diffused, indirect and adjustable light.
19 Photometric data.
21 Replaceable LEDs.

Ron Arad, Marco Dessí, Chia-Ying Lee, Dima Loginoff, Vittorio Massimo, Needs Studio, Luca Nichetto, Patrick Norguet, Snøhetta, Studio Italia Design, Andrea Tosetto, Pio & Tito Toso, YOY, Nika Zupanc.



Lodes collaborates with italian and international designers to shape unique lighting and decorative projects. Thanks to continuous research and experimentation, ideas take shape and the company becomes the meeting place for creative flair, technical expertise, and craftsmanship.

Lodes collabora con designer italiani e internazionali per creare progetti luminosi e decorativi unici. Grazie a continue ricerche e sperimentazioni, le idee prendono forma e l'azienda diventa il luogo d'incontro tra estro creativo, esperienza tecnica e artigianalità.



ED. 2024
New Lamps

01, 02	Cono di Luce small, Cono di Luce large, <i>design by</i> Ron Arad Suspension lamp	074
03	Cono di Luce, <i>design by</i> Ron Arad Table lamp	074
04-07	Random Cloud 7 lights, Random Cloud 14 lights, Random Cloud 19 lights, Random Cloud 23 lights, <i>design by</i> Chia-Ying Lee Suspension lamp	020
08	Random Solo 10, <i>design by</i> Chia-Ying Lee Cluster suspension lamp	130
09, 10	Sky-Fall Round medium, Sky-Fall Round large, <i>design by</i> Studio Italia Design Suspension lamp	046

Cluster suspension lamps

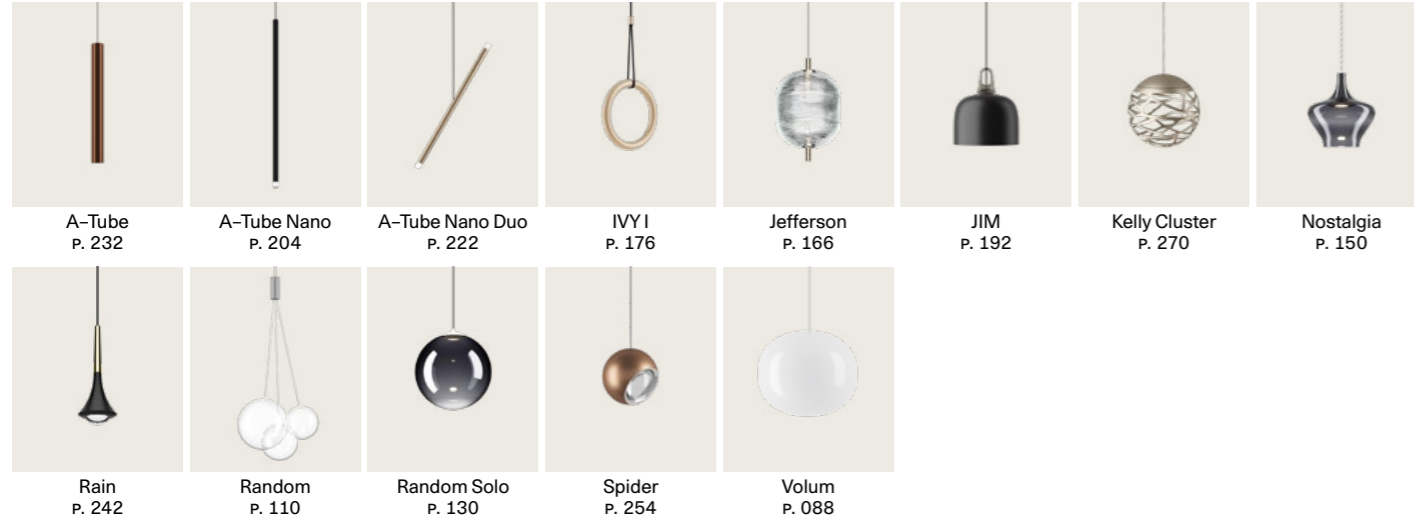

Ceiling lamps



Suspension lamps



Floor lamps



Table lamps

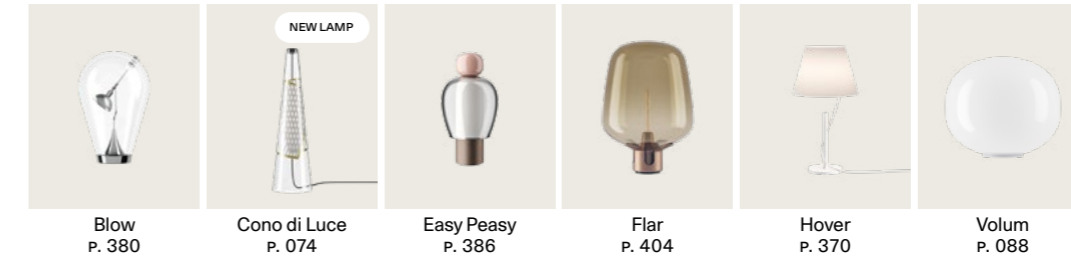

Wall lamps

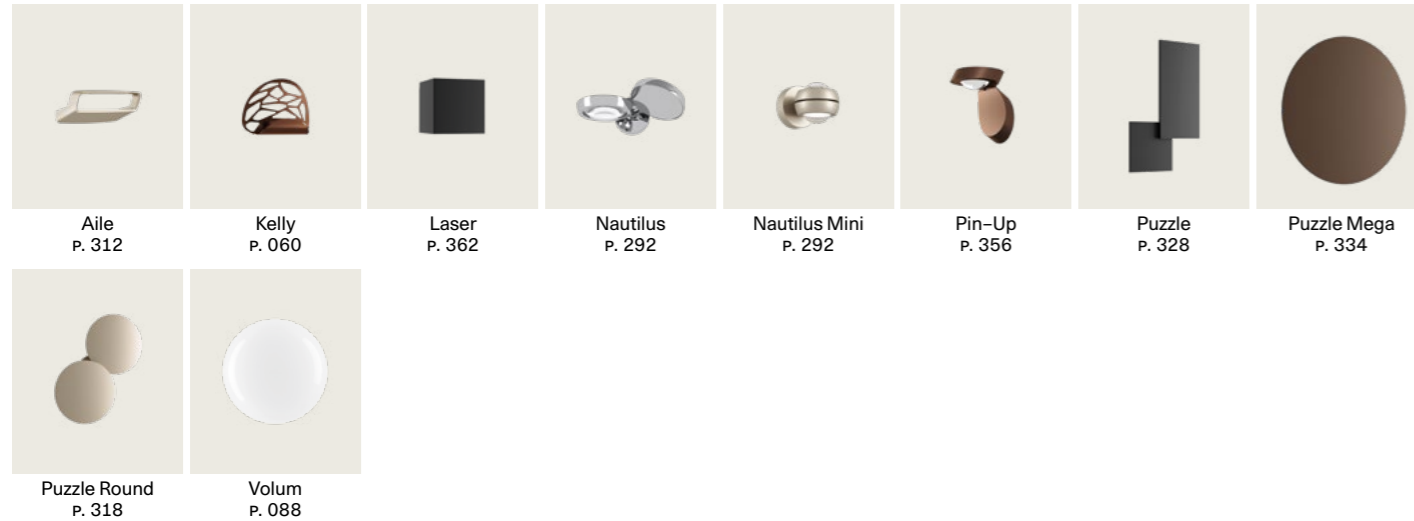

Random Cloud, design by Chia-Ying Lee, 2024

Random Cloud is a chandelier, an evolution of Lodes' *Random Solo* pendant, connecting multiple glass pendants to a central canopy. The pendants can be grouped to create 'clouds' of 7, 14, 19, or 23 via steel cables cut to precise lengths to create distinct 'cloud' formations. Each composition option can be achieved with spheres 23 or 28 cm in diameter and by choosing one of seven finishes available. The wide choice of compositions and configurations available to users makes *Random Cloud* a versatile option for homes, hospitality venues and workspaces alike.

● Spec sheet p. 030

Random Cloud è una sospensione stand-alone, l'evoluzione della sospensione *Random Solo* di Lodes, che ora unisce più elementi in vetro ad un rosone centrale. I vari elementi possono essere raggruppati per creare delle "nuvole" composte da 7, 14, 19 o 23, tramite cavi d'acciaio tagliati a lunghezze precise per creare differenti configurazioni di sfere. Ciascuna opzione di composizione può essere ottenuta con sfere di 23 oppure 28 cm di diametro e scegliendo una delle sette finiture disponibili. L'ampia scelta di configurazioni a disposizione degli utenti, rende *Random Cloud* un'opzione versatile per ambienti domestici, hospitality e uffici.



RANDOM CLOUD	CATEGORY LAMP		TYPE OF LIGHT	
	Suspension	Sospensione	Diffused light	Luce diffusa

NEW LAMP











Random Cloud est une suspension autonome, évolution de la suspension *Random Solo* de Lodes, qui associe désormais des éléments en verre à la patère centrale. Les différents éléments peuvent être regroupés en compositions de 7, 14, 19 ou 23 "nuages", à l'aide de câbles coupés à différentes longueurs pour créer plusieurs configurations de sphères. Chaque option de composition peut être obtenue avec des sphères de 23 ou 28 cm de diamètre, en choisissant l'une des sept finitions disponibles. La vaste gamme de configurations dont disposent les utilisateurs fait de *Random Cloud* une option polyvalente pour les environnements domestiques, hôteliers et de bureau. ● FR

Random Cloud ist eine Stand-Alone Aufhängung, die Evolution der Aufhängung von Lodes' *Random Solo*, die nun mehrere Glaselemente mit einem zentralen Baldachin kombiniert. Die verschiedenen Elemente lassen sich zu „Wolken“ zusammenstellen, die aus 7, 14, 19 oder 23 bestehen. Dazu werden Seile auf unterschiedliche Länge geschnitten, um verschiedene Kugelkonfigurationen zu schaffen.

Jede Kompositionsoption kann mit Kugeln mit einem Durchmesser von 23 oder 28 cm und einer der sieben verfügbaren Ausführungen realisiert werden. Die große Auswahl an Konfigurationen, die dem Benutzer zur Verfügung stehen, macht *Random Cloud* zu einer vielseitigen Option für Wohnbereiche, Hospitality- und Büroumgebungen. ● DE

Random Cloud es una suspensión independiente, la evolución de la suspensión *Random Solo* de Lodes, que ahora combina varios elementos de vidrio y un florón central. Los distintos elementos se pueden reagrupar para crear "nubes" formadas por 7, 14, 19 o 23 luces, mediante cables cortados de varias longitudes para crear diferentes combinaciones de esferas. Cada opción de composición se puede conseguir con esferas de 23 o 28 cm de diámetro y escogiendo uno de los siete acabados disponibles. El amplio abanico de configuraciones a disposición de los usuarios convierte *Random Cloud* en una opción versátil para entornos domésticos, de hostelería y oficinas. ● ES

Random Cloud – это отдельная подвесная лампа, эволюция подвесной лампы *Random Solo* Lodes, которая сочетает в себе несколько стеклянных элементов с центральным креплением. Различные элементы можно сгруппировать таким образом, чтобы создать «облака», состоящие из 7, 14, 19 или 23 сфер, с помощью тросов различной длины для создания разных конфигураций сфер. Каждый вариант композиции можно создать при помощи сфер диаметром 23 или 28 см, выбирая один из семи доступных вариантов отделки. Широкий выбор конфигураций, доступных пользователям, делает *Random Cloud* универсальным вариантом для домашних помещений, гостиниц и офисов. ● RU

Random Cloud 是一款独立悬吊灯,是Lodes的*Random Solo*悬吊灯的进阶版,该版本现在可将多个玻璃元素融合在同一个中央底盘上。各种元素可被组合创建为包含7只球体、14只球体、19只球体或23只球体的“云朵”,通过切割为不同长度的绳索来创建各不相同的球体配置。每个组合选项都可使用直径为23或28厘米的球体并选择所供七种饰面中的一种而获得。可供用户选择的丰富配置使得*Random Cloud* 成为一款适合居家、酒店和办公环境的多样之选。● ZH

Random Cloud 7 Lights Ø23 Random Cloud 7 Lights Ø28 » Suspension lamp **NEW LAMP**



Random Cloud 14 Lights Ø23 Random Cloud 14 Lights Ø28 » Suspension lamp **NEW LAMP**



Random Cloud 19 Lights Ø23 Random Cloud 19 Lights Ø28 » Suspension lamp **NEW LAMP**



Random Cloud 23 Lights Ø23 Random Cloud 23 Lights Ø28 » Suspension lamp **NEW LAMP**



CATEGORY **SUSPENSION LAMP**

DESIGN Chia-Ying Lee, 2024

Random Cloud 7 Lights Ø23 NEW

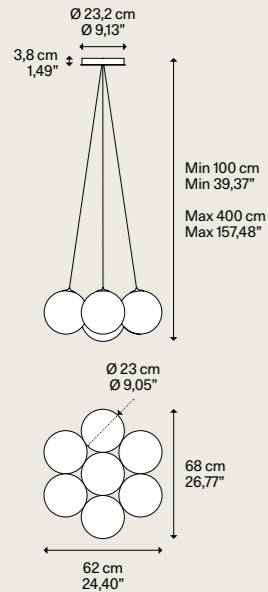

Blown glass diffuser
Diffusore in vetro soffiato

Clear Trasparente
Frosted White Bianco Satinato
Chrome Cromo
Glossy Smoke Fumo Lucido
Glossy Bronze Bronzo Lucido
Gold Oro
Rose Gold Oro Rosa

Metal canopy
Rosone in metallo

Matte White - 9010 Bianco Opaco - 9010

Code Codice	A	Code Codice	B
22121 0027U		22121 0030U	
22121 1327U		22121 1330U	
22121 4027U		22121 4030U	
22121 4327U		22121 4330U	
22121 4627U		22121 4630U	
22121 5027U		22121 5030U	
22121 5527U		22121 5530U	

Light source
Sorgente luminosa **A**

LED	
2700	K
28	W
3150	lm
220-240	V
CRI 90	
MacAdam 3-Step	

LED and driver included
LED e driver inclusi

Light source
Sorgente luminosa **B**

LED	
3000	K
28	W
3360	lm
220-240	V
CRI 90	
MacAdam 3-Step	

LED and driver included
LED e driver inclusi

Net weight 8,90 kg / 19,65 lbs | Pack Colli 15 | Mounts directly to a 4" Standard J-Box

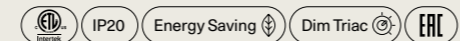

CATEGORY **SUSPENSION LAMP**

DESIGN Chia-Ying Lee, 2024

Random Cloud 14 Lights Ø23 NEW

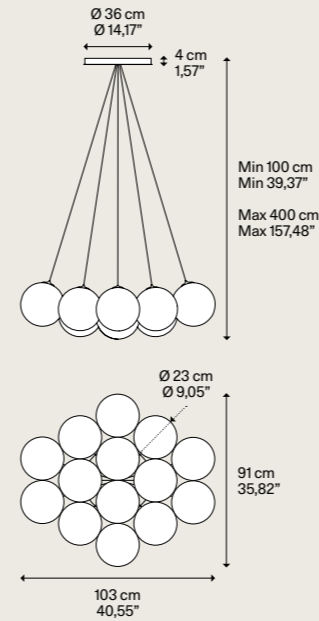

Blown glass diffuser
Diffusore in vetro soffiato

Clear Trasparente
Frosted White Bianco Satinato
Chrome Cromo
Glossy Smoke Fumo Lucido
Glossy Bronze Bronzo Lucido
Gold Oro
Rose Gold Oro Rosa

Metal canopy
Rosone in metallo

Matte White - 9010 Bianco Opaco - 9010

Code Codice	A	Code Codice	B
22123 0027U		22123 0030U	
22123 1327U		22123 1330U	
22123 4027U		22123 4030U	
22123 4327U		22123 4330U	
22123 4627U		22123 4630U	
22123 5027U		22123 5030U	
22123 5527U		22123 5530U	

Light source
Sorgente luminosa **A**

LED	
2700	K
56	W
6300	lm
220-240	V
CRI 90	
MacAdam 3-Step	

LED and driver included
LED e driver inclusi

Light source
Sorgente luminosa **B**

LED	
3000	K
56	W
6720	lm
220-240	V
CRI 90	
MacAdam 3-Step	

LED and driver included
LED e driver inclusi

Net weight 18,54 kg / 42,31 lbs | Pack Colli 29 | Connectable directly to a 4" Standard J-Box

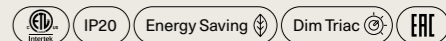

Random Cloud 7 Lights Ø28 NEW

Blown glass diffuser
Diffusore in vetro soffiato

Clear Trasparente
Frosted White Bianco Satinato
Chrome Cromo
Glossy Smoke Fumo Lucido
Glossy Bronze Bronzo Lucido
Gold Oro
Rose Gold Oro Rosa

Metal canopy
Rosone in metallo

Matte White - 9010 Bianco Opaco - 9010

Code Codice	A	Code Codice	B
22122 0027U		22122 0030U	
22122 1327U		22122 1330U	
22122 4027U		22122 4030U	
22122 4327U		22122 4330U	
22122 4627U		22122 4630U	
22122 5027U		22122 5030U	
22122 5527U		22122 5530U	

Light source
Sorgente luminosa **A**

LED	
2700	K
28	W
3150	lm
220-240	V
CRI 90	
MacAdam 3-Step	

LED and driver included
LED e driver inclusi

Light source
Sorgente luminosa **B**

LED	
3000	K
28	W
3360	lm
220-240	V
CRI 90	
MacAdam 3-Step	

LED and driver included
LED e driver inclusi

Net weight 13,80 kg / 30,43 lbs | Pack Colli 15 | Mounts directly to a 4" Standard J-Box

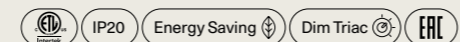

Random Cloud 14 Lights Ø28 NEW

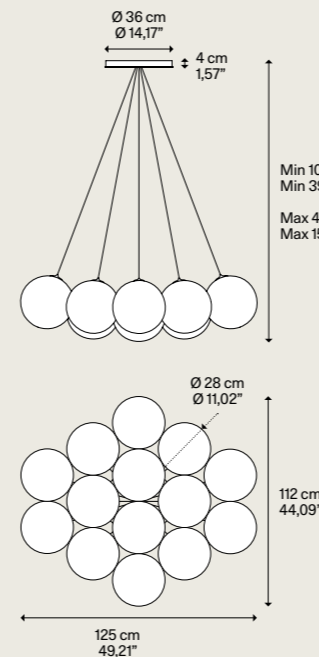

Blown glass diffuser
Diffusore in vetro soffiato

Clear Trasparente
Frosted White Bianco Satinato
Chrome Cromo
Glossy Smoke Fumo Lucido
Glossy Bronze Bronzo Lucido
Gold Oro
Rose Gold Oro Rosa

Metal canopy
Rosone in metallo

Matte White - 9010 Bianco Opaco - 9010

Code Codice	A	Code Codice	B
22124 0027U		22124 0030U	
22124 1327U		22124 1330U	
22124 4027U		22124 4030U	
22124 4327U		22124 4330U	
22124 4627U		22124 4630U	
22124 5027U		22124 5030U	
22124 5527U		22124 5530U	

Light source
Sorgente luminosa **A**

LED	
2700	K
56	W
6300	lm
220-240	V
CRI 90	
MacAdam 3-Step	

LED and driver included
LED e driver inclusi

Light source
Sorgente luminosa **B**

LED	
3000	K
56	W
6720	lm
220-240	V
CRI 90	
MacAdam 3-Step	

LED and driver included
LED e driver inclusi

Net weight 28,34 kg / 63,87 lbs | Pack Colli 29 | Connectable directly to a 4" Standard J-Box

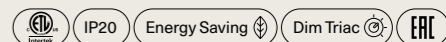

CATEGORY **SUSPENSION LAMP**

DESIGN Chia-Ying Lee, 2024

Random Cloud 19 Lights Ø23 **NEW**

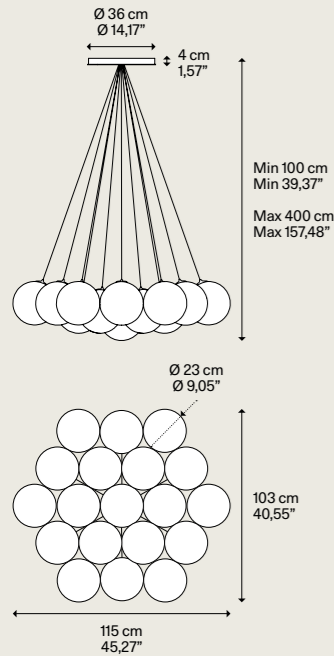

Blown glass diffuser
Diffusore in vetro soffiato

- Clear
Trasparente
- Frosted White
Bianco Satinato
- Chrome
Cromo
- Glossy Smoke
Fumo Lucido
- Glossy Bronze
Bronzo Lucido
- Gold
Oro
- Rose Gold
Oro Rosa

Metal canopy
Rosone in metallo

Code Codice **A** Code Codice **B**

- 22125 0027U 22125 0030U
- 22125 1327U 22125 1330U
- 22125 4027U 22125 4030U
- 22125 4327U 22125 4330U
- 22125 4627U 22125 4630U
- 22125 5027U 22125 5030U
- 22125 5527U 22125 5530U

Matte White - 9010
Bianco Opaco - 9010

Light source
Sorgente luminosa **A**

LED
2700 K
76 W
8550 lm
220-240 V
CRI 90
MacAdam 3-Step

LED and driver included
LED e driver inclusi

Light source
Sorgente luminosa **B**

LED
3000 K
76 W
9120 lm
220-240 V
CRI 90
MacAdam 3-Step

LED and driver included
LED e driver inclusi

Net weight 24,04 kg / 54,46 lbs | Pack Colli 39 | Connectable directly to a 4" Standard J-Box

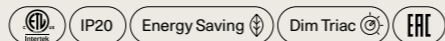

CATEGORY **SUSPENSION LAMP**

DESIGN Chia-Ying Lee, 2024

Random Cloud 23 Lights Ø23 **NEW**

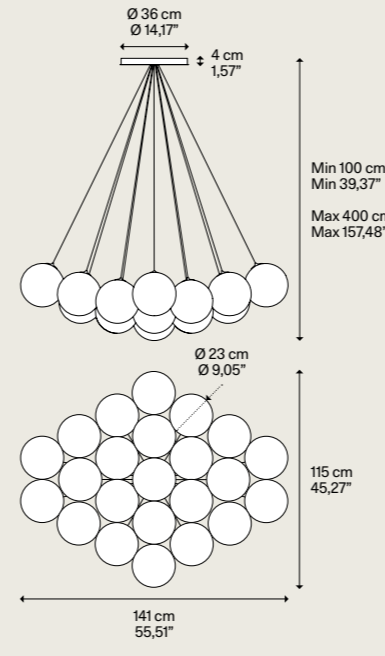

Blown glass diffuser
Diffusore in vetro soffiato

- Clear
Trasparente
- Frosted White
Bianco Satinato
- Chrome
Cromo
- Glossy Smoke
Fumo Lucido
- Glossy Bronze
Bronzo Lucido
- Gold
Oro
- Rose Gold
Oro Rosa

Metal canopy
Rosone in metallo

Code Codice **A** Code Codice **B**

- 22127 0027U 22127 0030U
- 22127 1327U 22127 1330U
- 22127 4027U 22127 4030U
- 22127 4327U 22127 4330U
- 22127 4627U 22127 4630U
- 22127 5027U 22127 5030U
- 22127 5527U 22127 5530U

Matte White - 9010
Bianco Opaco - 9010

Light source
Sorgente luminosa **A**

LED
2700 K
92 W
10350 lm
220-240 V
CRI 90
MacAdam 3-Step

LED and driver included
LED e driver inclusi

Light source
Sorgente luminosa **B**

LED
3000 K
92 W
11040 lm
220-240 V
CRI 90
MacAdam 3-Step

LED and driver included
LED e driver inclusi

Net weight 28,44 kg / 64,18 lbs | Pack Colli 47 | Connectable directly to a 4" Standard J-Box

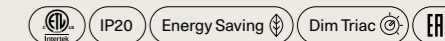

Random Cloud 19 Lights Ø28 **NEW**

DESIGN Chia-Ying Lee, 2024

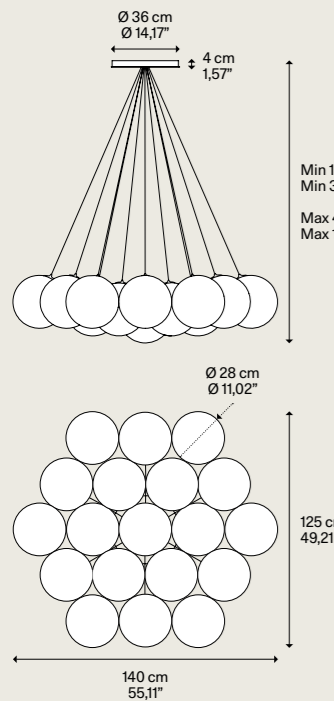

Blown glass diffuser
Diffusore in vetro soffiato

- Clear
Trasparente
- Frosted White
Bianco Satinato
- Chrome
Cromo
- Glossy Smoke
Fumo Lucido
- Glossy Bronze
Bronzo Lucido
- Gold
Oro
- Rose Gold
Oro Rosa

Metal canopy
Rosone in metallo

Code Codice **A** Code Codice **B**

- 22126 0027U 22126 0030U
- 22126 1327U 22126 1330U
- 22126 4027U 22126 4030U
- 22126 4327U 22126 4330U
- 22126 4627U 22126 4630U
- 22126 5027U 22126 5030U
- 22126 5527U 22126 5530U

Matte White - 9010
Bianco Opaco - 9010

Light source
Sorgente luminosa **A**

LED
2700 K
76 W
8550 lm
220-240 V
CRI 90
MacAdam 3-Step

LED and driver included
LED e driver inclusi

Light source
Sorgente luminosa **B**

LED
3000 K
76 W
9120 lm
220-240 V
CRI 90
MacAdam 3-Step

LED and driver included
LED e driver inclusi

Net weight 37,34 kg / 83,72 lbs | Pack Colli 39 | Connectable directly to a 4" Standard J-Box

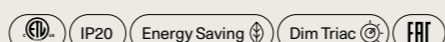

Random Cloud 23 Lights Ø28 **NEW**

DESIGN Chia-Ying Lee, 2024

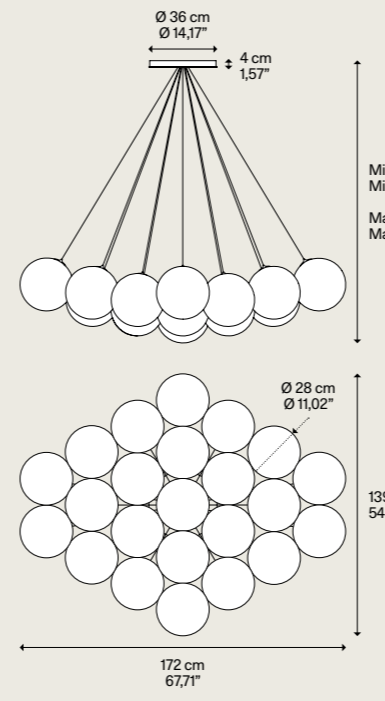

Blown glass diffuser
Diffusore in vetro soffiato

- Clear
Trasparente
- Frosted White
Bianco Satinato
- Chrome
Cromo
- Glossy Smoke
Fumo Lucido
- Glossy Bronze
Bronzo Lucido
- Gold
Oro
- Rose Gold
Oro Rosa

Metal canopy
Rosone in metallo

Code Codice **A** Code Codice **B**

- 22128 0027U 22128 0030U
- 22128 1327U 22128 1330U
- 22128 4027U 22128 4030U
- 22128 4327U 22128 4330U
- 22128 4627U 22128 4630U
- 22128 5027U 22128 5030U
- 22128 5527U 22128 5530U

Matte White - 9010
Bianco Opaco - 9010

Light source
Sorgente luminosa **A**

LED
2700 K
92 W
10350 lm
220-240 V
CRI 90
MacAdam 3-Step

LED and driver included
LED e driver inclusi

Light source
Sorgente luminosa **B**

LED
3000 K
92 W
11040 lm
220-240 V
CRI 90
MacAdam 3-Step

LED and driver included
LED e driver inclusi

Net weight 44,54 kg / 99,60 lbs | Pack Colli 47 | Connectable directly to a 4" Standard J-Box

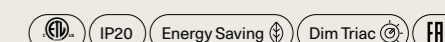

Elara, design by Nika Zupanc, 2022

The name *Elara* connotes astronomy and Greek mythology, and its geometric design mimicks the trajectory of the planets within the universe. Inspired by astral motion, the lamp is characterised by two metal rings, one of which can be set at various angles to produce fluidity and movement, as well as a small sphere at the bottom of the lamp that contains the light source. The central ring can be positioned to reach different heights and angles, allowing users to experiment with casting light and shadows. The light source emits a glow that can illuminate an entire room. Additionally, when the lamp is off, users can direct the bi-emission sphere – up or down – according to the need for light.

● Spec sheet p. 045

Il nome *Elara* richiama l'astronomia e la mitologia greca, e il suo design geometrico imita la traiettoria dei pianeti nell'universo. Ispirata al movimento astrale, la lampada è caratterizzata da due anelli metallici, uno dei quali può essere posizionato a varie angolazioni per produrre fluidità e movimento, e da una piccola sfera all'estremità inferiore della lampada che contiene la sorgente luminosa. L'anello centrale può essere posizionato in modo da raggiungere diverse altezze e angolazioni, consentendo agli utenti di sperimentare la proiezione di luci e ombre. La sorgente luminosa emette un bagliore che può illuminare un'intera stanza. Inoltre quando la lampada è spenta, è possibile per gli utenti orientare la sfera a doppia emissione – verso l'alto o verso il basso – in base alle esigenze di luce.



ELARA	CATEGORY LAMP		TYPE OF LIGHT	
	Suspension	Sospensione	Symmetrical diffused light Adjustable	Luce simmetrica diffusa Orientabile







Elara, metal rings, FINISH Glossy Black.



039 Suspension lamp

Elara large, FINISH Black.

Elara





1

1 Elara is characterised by two metal rings, one of which can be set at various angles.



2

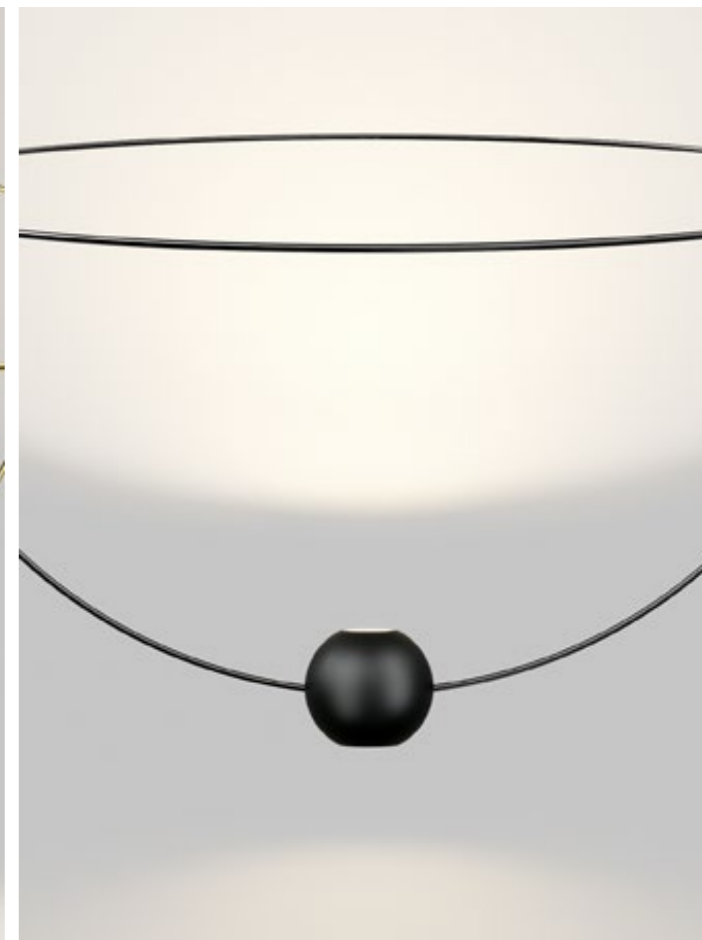

3

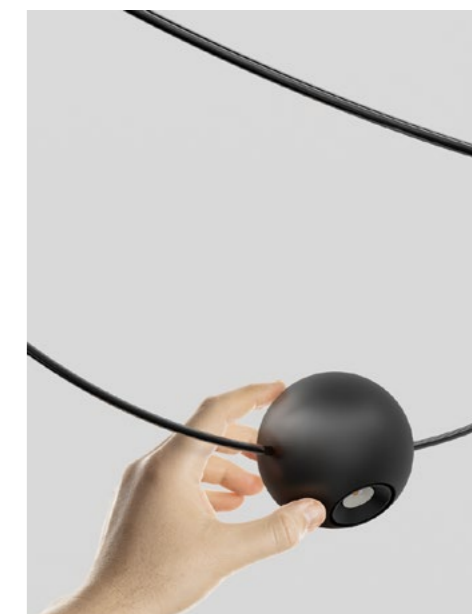

4

2 Elara, metal sphere, side I (down) side II (up), FINISH Matte Gold.
3 Elara, metal sphere, side I (up) side II (down), FINISH Extra Matte Black.
4 Elara, metal sphere, FINISH Extra Matte Black.

Le nom *Elara* évoque l'astronomie et la mythologie grecque, et son design géométrique imite la trajectoire des planètes dans l'univers. S'inspirant du mouvement astral, la lampe se caractérise par deux anneaux métalliques : un pouvant être positionné à différents angles, créant ainsi fluidité et mouvement, et par une petite sphère à l'extrémité inférieure de la lampe qui abrite la source lumineuse. L'anneau central peut être positionné pour atteindre différents angles et hauteurs, permettant aux utilisateurs d'expérimenter la projection de lumière et d'ombre. La source lumineuse émet un rayonnement lumineux qui peut éclairer toute une pièce. De plus, lorsque la lampe est éteinte, les utilisateurs peuvent orienter la sphère à double émission – vers le haut ou vers le bas – en fonction des exigences de lumière. ●FR

Der Name *Elara* erinnert an die Astronomie und die griechische Mythologie, und so ahmt das geometrische Design der Leuchte die Flugbahn der Planeten im Universum nach. Inspiriert von diesen astralen Bewegungen besteht die Leuchte aus zwei Metallringen, von denen einer in verschiedenen Winkeln positioniert werden kann, um eine fließende Bewegung zu erzeugen, sowie aus einer kleinen Kugel am unteren Ende der Leuchte, welche die Lichtquelle enthält. Der zentrale Ring kann in verschiedenen Höhen und Winkeln positioniert werden, so dass die Benutzer mit der Projektion von Licht und Schatten experimentieren können. Die Lichtquelle strahlt ein Licht aus, das einen ganzen Raum erhellen kann. Außerdem kann der Benutzer die Dual-Emissionskugel bei ausgeschalteter Leuchte je nach Lichtbedarf nach oben oder nach unten ausrichten. ●DE

El nombre *Elara* evoca la astronomía y la mitología griega y su diseño geométrico imita la trayectoria de los planetas en el universo. Inspirada en el movimiento astral, la lámpara se caracteriza por dos anillos metálicos, uno de los cuales se puede colocar en distintos ángulos para crear fluidez y movimiento, y una pequeña esfera en el extremo inferior de la lámpara que contiene la fuente luminosa. El anillo central se puede colocar de forma que alcance distintas alturas y ángulos y permite a los usuarios experimentar la proyección de luces y sombras. La fuente luminosa emite un destello que puede iluminar toda una habitación. Además, cuando la lámpara está apagada, los usuarios pueden orientar la esfera con doble emisión – hacia arriba o hacia abajo – dependiendo de la luz que se necesite. ●ES

Название *Elara* напоминает нам об астрономии и греческой мифологии, ее геометрический дизайн имитирует траектории движения планет во вселенной. Лампа, вдохновленная движением звезд, имеет два металлических кольца, одно из которых может устанавливаться под разными углами, создавая текучесть и мобильность, и небольшую сферу на нижней стороне лампы, содержащей внутри источник освещения. Центральное кольцо можно располагать на различной высоте и под разными углами, что позволяет пользователям экспериментировать с проекцией света и тени. Источник света излучает свечение, наполняющее всю комнату. Кроме того, когда лампа выключена, пользователи могут ориентировать сферу с двойным излучением вверх или вниз в зависимости от потребности в освещении. ●RU

Elara—名呼应天文学和希腊神话,同时它的几何设计还仿照宇宙中的行星运行轨迹。受星体运动的启发,两只金属圆环是这款灯的特色所在,其中一能够以不同角度定位,从而产生流动性和运动性,并使灯体下端形成一个容纳光源的小球体。中心圆环通过定位可达到不同高度和角度,允许用户尝试光与影的投射。光源发出的光芒可照亮整个房间。此外,当灯熄灭时,用户可以根据自身的光线需求将双发射球体向上或向下调转。●ZH

CATEGORY SUSPENSION LAMP

Elara medium

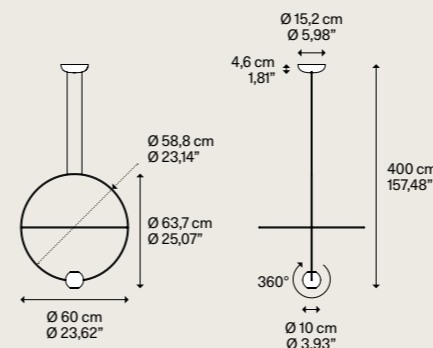

DESIGN Nika Zupanc 2022

Metal structure
Montatura in metallo

- Glossy Black
Nero Lucido
- Glossy Gold
Oro Lucido

Metal sphere
Sfera in metallo

- Extra Matte Black
Nero Extra Opaco
- Matte Gold
Oro Opaco

Code
Codice

- 20621 2230U
- 20621 5030U

Light source
Sorgente luminosa

- LED 3000 K
- 33 W
- 2260 lm-side I
- 845 lm-side II
- 1000 mA
- CRI 90
- MacAdam 3-Step

LED and driver included
LED e driver inclusi

- Net weight 1,67 kg / 3,68 lbs
- Boxes Colli 1
- Mounts directly to a 4" Standard J-Box

- IP20
- Energy Saving
- Dim Triac

Elara large

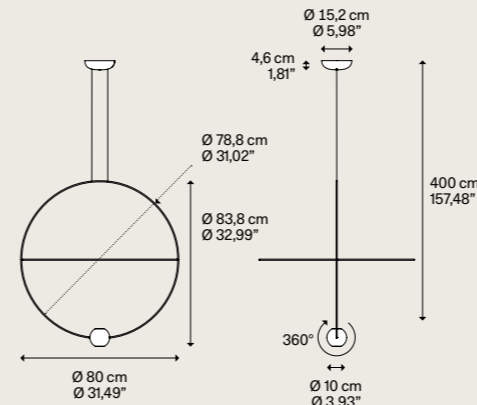

Metal structure
Montatura in metallo

- Glossy Black
Nero Lucido
- Glossy Gold
Oro Lucido

Metal sphere
Sfera in metallo

- Extra Matte Black
Nero Extra Opaco
- Matte Gold
Oro Opaco

Code
Codice

- 20622 2230U
- 20622 5030U

Light source
Sorgente luminosa

- LED 3000 K
- 33 W
- 2260 lm-side I
- 845 lm-side II
- 1000 mA
- CRI 90
- MacAdam 3-Step

LED and driver included
LED e driver inclusi

- Net weight 1,87 kg / 4,12 lbs
- Boxes Colli 1
- Mounts directly to a 4" Standard J-Box

- IP20
- Energy Saving
- Dim Triac

Elara medium ↘ Suspension lamp



Elara large ↘ Suspension lamp



Adjustable light
Luce orientabile

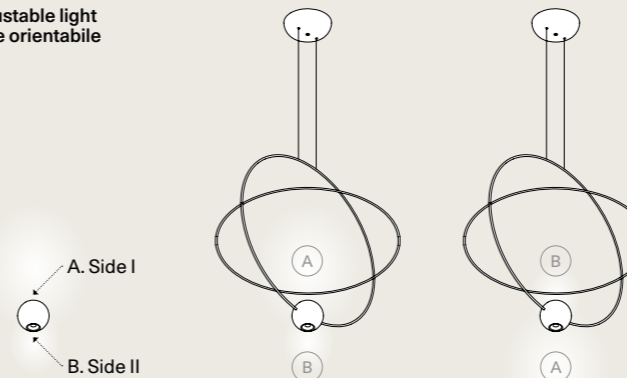

Adjustable ring
Anello orientabile

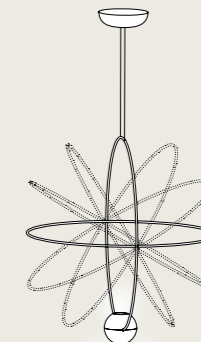

Sky-Fall, design by Studio Italia Design, 2014/2024

In *Sky-Fall*, the traditional glass processing techniques embrace the most advanced LED technologies. The shape of *Sky-Fall* captures the imagination in its reminiscence of ancient decanters in precious blown glass. Its function amazes thanks to the innovative double LED source that diffuses direct and indirect light. Available in two sizes and in four finishes, *Sky-Fall* decorates both when it is on and when it is off. Now added to the family is the new *Sky-Fall Round*: a further variant featuring a spherically shaped diffuser available in two sizes and four finishes, including the new, precious golden sage. The new finish also extends to *Sky-Fall* in both sizes.

● Spec sheet p. 057

In *Sky-Fall* le tradizionali tecniche di lavorazione del vetro abbracciano le tecnologie LED più avanzate. La forma di *Sky-Fall* emoziona ricordando antichi decanter in prezioso vetro soffiato. La sua funzione stupisce grazie all'innovativa doppia sorgente a LED che diffonde luce diretta e indiretta. Disponibile in due dimensioni e in quattro finiture, *Sky-Fall* arreda sia da accesa che da spenta. Si aggiunge ora alla famiglia la nuova *Sky-Fall Round*: un'ulteriore variante che presenta un diffusore dalla forma sferica disponibile in due dimensioni e quattro finiture, inclusa la nuova e preziosa golden sage (salvia dorata). La nuova finitura si estende anche a *Sky-Fall* in entrambe le misure.



SKY-FALL	CATEGORY LAMP		TYPE OF LIGHT	
	Suspension	Sospensione	Diffused light	Luce diffusa

NEW LAMP









Clear



Glossy Smoke



Glossy Bronze



Golden Sage





Avec *Sky-Fall*, les techniques traditionnelles d'ennoblissement du verre embrassent les technologies LED les plus pointues. La Forme de *Sky-Fall* émeut car elle évoque les anciens décanteurs en verre soufflé précieux. Sa fonction surprend avec sa double source à LED qui diffuse de la lumière directe et indirecte. Disponible en deux dimensions et quatre finitions, *Sky-Fall*, allumée ou éteinte, se prête à la création d'atmosphères. La nouvelle *Sky-Fall Round* rejoint la famille : une autre variante qui présente un diffuseur de forme sphérique disponible en deux dimensions et quatre finitions, comprenant la nouvelle et précieuse Golden Sage (saugée dorée). La nouvelle finition s'applique également à *Sky-Fall* dans les deux dimensions. [FR](#)

Bei *Sky-Fall* treffen traditionelle Glasverarbeitungstechniken auf fortschrittlichste LED-Technologien. Die Form von *Sky-Fall* begeistert und erinnert an alte Dekanter aus hochwertigem, geblasenem Glas. Seine Funktion beeindruckt dank der innovativen, doppelten LED-Lichtquelle, die gleichzeitig für direkte und indirekte Beleuchtung sorgt. *Sky-Fall* ist in zwei Größen und vier Ausführungen sowie in den Farbtemperaturen 2700 K erhältlich und statet den Raum sowohl im eingeschalteten als auch im ausgeschalteten Zustand aus. Jetzt wird die Familie um die neue *Sky-Fall Round* erweitert: eine weitere Variante mit einem

kugelförmigen Diffusor, die in zwei Größen und vier Ausführungen erhältlich ist, darunter das neue, edle Golden Sage (Salbei Gold). Die neue Ausführung erstreckt sich auch auf *Sky-Fall* in beiden Größen. [DE](#)

En *Sky-Fall* las tradicionales técnicas de elaboración del vidrio abrazan las tecnologías LED más avanzadas. La forma de *Sky-Fall* emociona recordando antiguos decantadores en precioso vidrio soplado. Su función sorprende gracias a la innovadora doble fuente de LED que difunde luz directa e indirecta. Disponible en dos tamaños, *Sky-Fall* decora tanto encendida como apagada. Ahora se añade a la familia la nueva *Sky-Fall Round*: una variante adicional con un difusor de forma esférica disponible en dos tamaños y cuatro acabados, incluida la nueva y preciosa golden sage (salvia dorada). El nuevo acabado también abarca *Sky-Fall* en ambas medidas. [ES](#)

Традиционная техника обработки стекла сочетается в *Sky-Fall* с наиболее совершенными светодиодными технологиями. Форма *Sky-Fall* захватывает воображение отсылкой к старинным декантерам из драгоценного дутого стекла. Он отличается поразительной функциональностью, благодаря инновационному двойному светодиодному источнику, который рассеивает прямой и непрямой свет. Светильник выпускается

в двух размерах и четырех вариантах отделки, и в версии с цветовой температурой 2700K *Sky-Fall* украшает помещение как во включенном, так и в выключенном состоянии. Теперь к семейству светильников добавился новый *Sky-Fall Round*: это дополнительный вариант со сферическим диффузором, доступный в двух размерах и четырех вариантах отделки, включая новую драгоценную отделку golden sage (золотой шалфей). Новая отделка также распространяется на *Sky-Fall* обоих размеров. [RU](#)

*Sky-Fall*将传统的玻璃处理工艺与最为先进的LED技术完美融合。*Sky-Fall*的形状精美,令人忆起以珍贵玻璃吹制工艺精制而成的古老醒酒器。得益于创新型LED光源散射射出的直接与间接光线,它的功能令人赞叹。提供两种尺寸和四种饰面,同时还有2700 K色温的两个版本,无论是在点亮或熄灭时皆可营造迷人装饰效果。该系列现在还添入了全新的*Sky-Fall Round*:一款带有球形灯罩的延伸产品,提供两种尺寸和两种饰面,包含新颖珍贵的Golden Sage(金鼠尾草色)饰面。这款全新饰面也将延伸至*Sky-Fall*的两种尺寸中。[ZH](#)

Sky-Fall medium » Suspension lamp

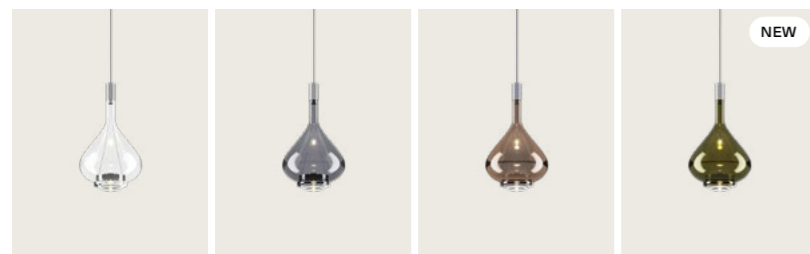

Sky-Fall large » Suspension lamp



Sky-Fall Round medium » Suspension lamp NEW LAMP

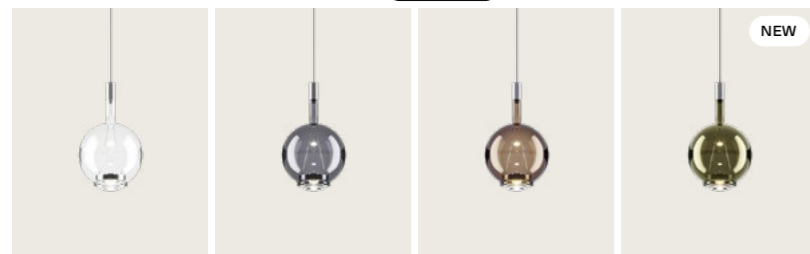

Sky-Fall Round large » Suspension lamp NEW LAMP

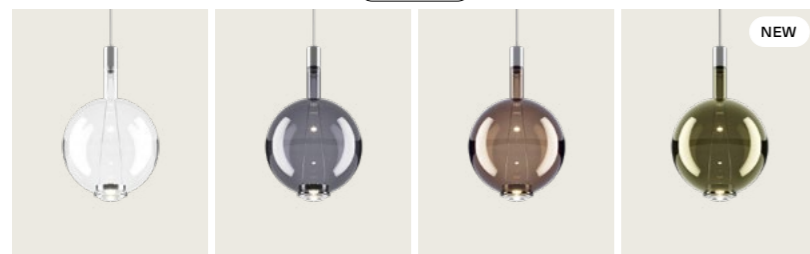

Double canopy

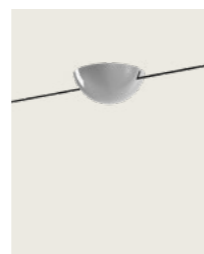

CATEGORY SUSPENSION LAMP

Sky-Fall medium

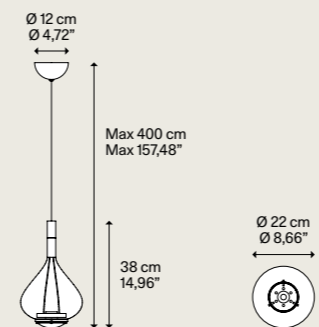

DESIGN Studio Italia Design, 2014

Metal structure
Montatura in metallo



Light source
Sorgente luminosa

LED
2700 K
20 W
2000 lm
350 mA
CRI 90
MacAdam 3-Step

LED and driver included
LED e driver inclusi

Net weight 1,65 kg / 3,64 lbs | Boxes Colli 2 | Mounts directly to a 4" Standard J-Box

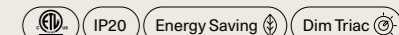

Sky-Fall large

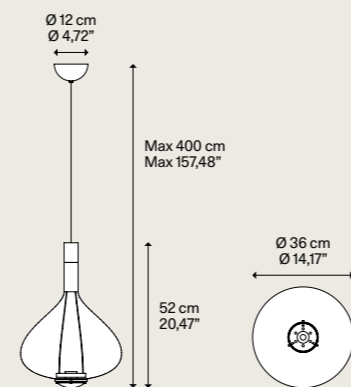

Metal structure
Montatura in metallo

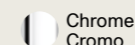

Light source
Sorgente luminosa

LED
2700 K
20 W
2000 lm
350 mA
CRI 90
MacAdam 3-Step

LED and driver included
LED e driver inclusi

Net weight 3,05 kg / 6,72 lbs | Boxes Colli 2 | Mounts directly to a 4" Standard J-Box

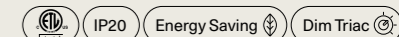

Blown glass diffuser
Diffusore in vetro soffiato

Color	Code
Clear Trasparente	14822 0027U
Glossy Smoke Fumo Lucido	14822 4327U
Glossy Bronze Bronzo Lucido	14822 4627U
Golden Sage ^{NEW} Salvia Dorata	14822 7127U

Blown glass diffuser
Diffusore in vetro soffiato

Color	Code
Clear Trasparente	14821 0027U
Glossy Smoke Fumo Lucido	14821 4327U
Glossy Bronze Bronzo Lucido	14821 4627U
Golden Sage ^{NEW} Salvia Dorata	14821 7127U

CATEGORY **SUSPENSION LAMP**

DESIGN Studio Italia Design, 2024

Sky-Fall round medium **NEW**

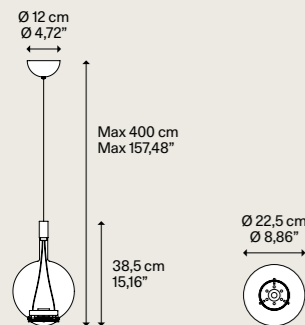

Metal structure Montatura in metallo	Blown glass diffuser Diffusore in vetro soffiato	Code Codice
Chrome Cromo	Clear Trasparente	14824 0027U
	Glossy Smoke Fumo Lucido	14824 4327U
	Glossy Bronze Bronzo Lucido	14824 4627U
	Golden Sage NEW Salvia Dorata	14824 7127U

Light source
Sorgente luminosa

LED
2700 K
20 W
2000 lm
350 mA
CRI 90
MacAdam 3-Step

LED and driver included
LED e driver inclusi

Net weight 1,47 kg / 3,24 lbs | Boxes Colli 2 | Mounts directly to a 4" Standard J-Box

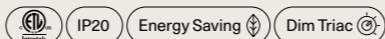

Sky-Fall round large **NEW**

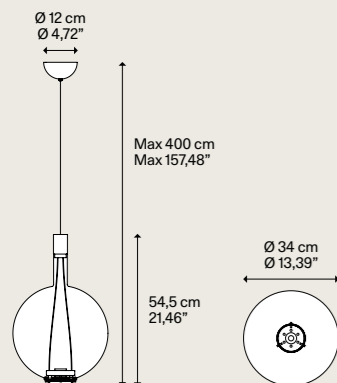

Metal structure Montatura in metallo	Blown glass diffuser Diffusore in vetro soffiato	Code Codice
Chrome Cromo	Clear Trasparente	14823 0027U
	Glossy Smoke Fumo Lucido	14823 4327U
	Glossy Bronze Bronzo Lucido	14823 4627U
	Golden Sage NEW Salvia Dorata	14823 7127U

Light source
Sorgente luminosa

LED
2700 K
20 W
2000 lm
350 mA
CRI 90
MacAdam 3-Step

LED and driver included
LED e driver inclusi

Net weight 2,64 kg / 5,82 lbs | Boxes Colli 2 | Mounts directly to a 4" Standard J-Box

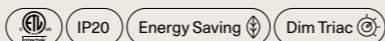

CATEGORY **DOUBLE CANOPY**

Sky-Fall double canopy

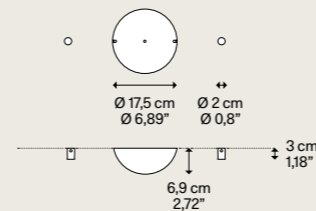

Net weight 0,56 kg / 1,23 lbs | Boxes Colli 1



Description Descrizione	Metal structure Montatura in metallo	System Sistema	Code Codice
Double canopy mod. Sky-Fall Rosone doppio mod. Sky-Fall	Chrome Cromo	Sky-Fall System	R99L02 4000U

CATEGORY **WALL CANOPY**

Wall Standard

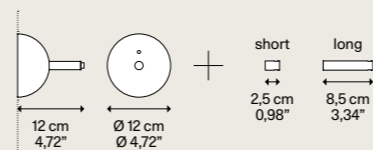

Net weight 0,40 kg / 0,88 lbs | Boxes Colli 1 | Mounts directly to a 4" Standard J-Box



Description Descrizione	Metal structure Montatura in metallo	System Sistema	Code Codice
Wall bracket mod. Sky-Fall Rosone a parete mod. Sky-Fall	Chrome Cromo	Sky-Fall System	R12L01 4000U

CATEGORY **TRACK**

Short Lights Track

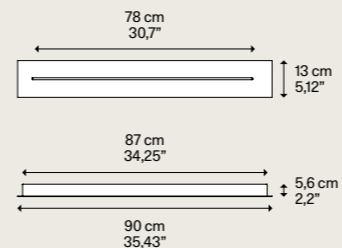

Net weight 7,33 kg / 16,16 lbs | Boxes Colli 1 | Connectable directly to a 4" Standard J-Box



Description Descrizione	Metal structure Struttura in metallo	System Sistema	Code Codice
Multiple linear track mod. Sky-Fall max 3 suspensions	Matte White - 9010 Bianco Opaco - 9010	Track	R08L07 1000U
Binario lineare multiplo mod. Sky-Fall max 3 sospensioni	Matte Black - 9005 Nero Opaco - 9005		R08L07 2000U

Long Lights Track

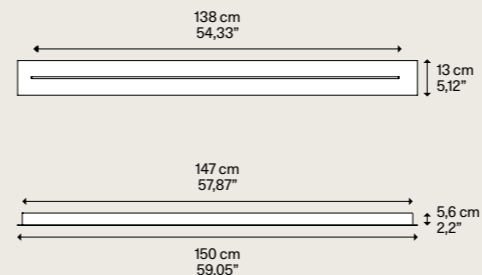

Net weight 11,85 kg / 26,12 lbs | Boxes Colli 1 | Connectable directly to a 4" Standard J-Box



Description Descrizione	Metal structure Struttura in metallo	System Sistema	Code Codice
Multiple linear track mod. Sky-Fall max 5 suspensions	Matte White - 9010 Bianco Opaco - 9010	Track	R08L11 1000U
Binario lineare multiplo mod. Sky-Fall max 5 sospensioni	Matte Black - 9005 Nero Opaco - 9005		R08L11 2000U

► WALL STANDARD Both accessories in the two available lengths are supplied in the box with the wall bracket. ► TRACK Tracks are only for Sky-Fall suspensions. Each suspension should be separated from the canopy and installed on the track. Each suspension should be installed on the track using the driver removed from the original canopy.

► WALL STANDARD Entrambi gli accessori nelle due diverse lunghezze sono inclusi nella confezione con il supporto a parete. ► TRACK I binari sono utilizzabili solo con le sospensioni Sky-Fall che dovranno essere separate dai rosone ed installate sui binari. Per ogni sospensione dovrà essere installato nel binario il rispettivo driver rimosso dal rosone originale.

Kelly, design by Andrea Tosetto, 2015

Seductive beauty with a bold personality thanks to the strong and precise laser cuts, which lighten the metal of the lampshade and create an intriguing play of light and shadow. *Kelly* is a multifaceted family of suspension and wall lamps that stand out with elegance in any living space thanks to the variety of available forms and finishes.

● Spec sheet p. 069

Una bellezza seducente dalla personalità audace grazie a tagli laser forti e precisi che alleggeriscono il metallo del paralume e creano un intrigante gioco di luci e ombre. *Kelly* è una famiglia poliedrica di lampade a sospensione e a parete che si distingue con eleganza in ogni ambiente abitativo grazie alla varietà di forme e finiture disponibili.



KELLY	CATEGORY LAMP		TYPE OF LIGHT	
	Suspension Wall	Sospensione Parete	Symmetrical diffused light	Luce simmetrica diffusa





Kelly small dome 50, FINISH Matte Black.



Kelly large dome 80, FINISH Matte Black.





Kelly small sphere 50, Kelly medium sphere 60 and Kelly large sphere 80, FINISH Coppery Bronze.



067 Suspension lamp Kelly small dome 50, FINISH Coppery Bronze.

Une beauté séduisante d'une personnalité audacieuse grâce aux découpes laser puissantes et précises qui allègent le métal de l'abat-jour et créent un intrigant jeu de lumière et d'ombres. *Kelly* est une famille polyédrique de lampes à suspension et d'appliques qui se distingue avec élégance dans toutes les pièces de vie grâce à la variété de formes et de finitions disponibles. ●FR

Una belleza seductora con una personalidad atrevida gracias a fuertes y precisos cortes de láser que iluminan el metal de la pantalla de la lámpara y crean un intrigante juego de luces y sombras. *Kelly* es una versátil familia de lámparas colgantes y de pared que destaca con elegancia en todos los entornos gracias a la variedad de formas y acabados disponibles. ●ES

Соблазнительная красота с решительным характером создана благодаря четким и выразительным прорезам, выполненным методом лазерной резки, которые облегчают металлический абажур и создают интригующую игру света и тени. *Kelly* – это семейство универсальных подвесных и настенных светильников, которые элегантно украшают любой жилой интерьер благодаря разнообразию доступных форм и отделки. ●RU

强劲而精确的激光切割使灯罩的金属发亮，并创造出有趣的光影效果，具有诱人的美感和大胆的个性。*Kelly* 是一个悬吊式和壁灯系列的产品，其多种多样的外形和颜色使其在任何生活环境中均格外高雅。 ●ZH

Verführerische Schönheit mit gewagter Persönlichkeit, die durch starke und genaue Laserschnitte zum Ausdruck gebracht wird, die das Metall des Lampenschirms leicht erscheinen lassen und ein betrügerisches Spiel aus Licht und Schatten schaffen. *Kelly* ist eine vielseitige Familie aus Hänge- und Wandleuchten, die sich durch Eleganz in jedem Wohnraum auszeichnet, die den verschiedenen verfügbaren Formen und Ausführungen zu verdanken ist. ●DE

Kelly small dome 50 ↗ Suspension lamp

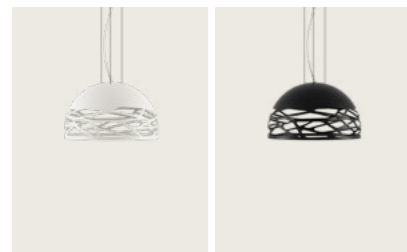

Kelly small sphere 40 ↗ Suspension lamp

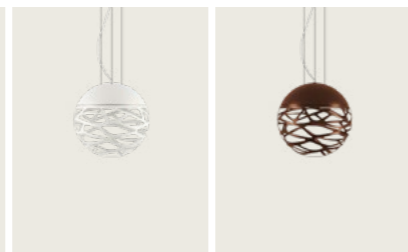

Kelly medium dome 60 ↗ Suspension lamp

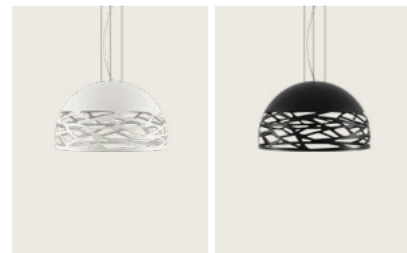

Kelly medium sphere 50 ↗ Suspension lamp

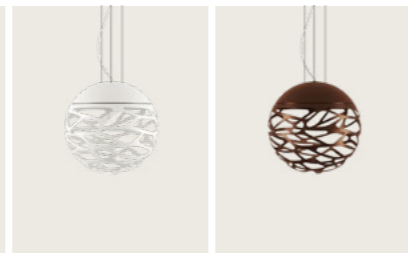

Kelly large dome 80 ↗ Suspension lamp



Kelly large sphere 80 ↗ Suspension lamp

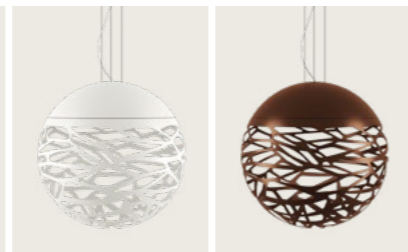

Kelly ↗ Wall lamp

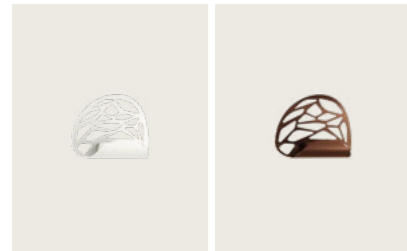

CATEGORY SUSPENSION LAMP

Kelly small dome 50

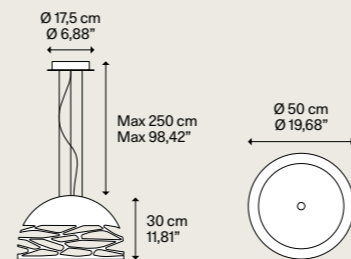

DESIGN Andrea Tosetto, 2015

Metal structure
Montatura in metallo

- Matte White - 9010
Bianco Opaco - 9010
- Matte Black - 9005
Nero Opaco - 9005
- Coppery Bronze
Bronzo Ramato
- Matte Champagne
Champagne Opaco

Glass diffuser
Diffusore in vetro

- Glossy White
Bianco Lucido

Code
Codice

- 14126 1000U
- 14126 2000U
- 14126 3500U
- 14126 4500U

Light source
Sorgente luminosa

Medium Base
E26 LED 3x 25 W 120 V
W/L max 12 cm
W/L max 4,72"

Bulb not included
Lampadina non inclusa

Net weight 6,00 kg
Peso netto 13,23 lbs

Boxes 1
Colli 1

Mounts directly to a 4" Standard J-Box

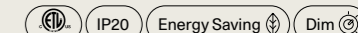

Kelly medium dome 60

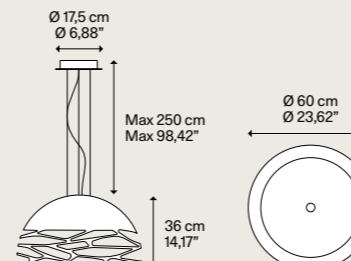

Metal structure
Montatura in metallo

- Matte White - 9010
Bianco Opaco - 9010
- Matte Black - 9005
Nero Opaco - 9005
- Coppery Bronze
Bronzo Ramato
- Matte Champagne
Champagne Opaco

Glass diffuser
Diffusore in vetro

- Glossy White
Bianco Lucido

Code
Codice

- 14127 1000U
- 14127 2000U
- 14127 3500U
- 14127 4500U

Light source
Sorgente luminosa

Medium Base
E26 LED 3x 25 W 120 V
W/L max 12 cm
W/L max 4,72"

Bulb not included
Lampadina non inclusa

Net weight 7,15 kg
Peso netto 15,76 lbs

Boxes 1
Colli 1

Mounts directly to a 4" Standard J-Box

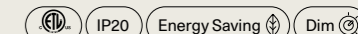

Kelly large dome 80

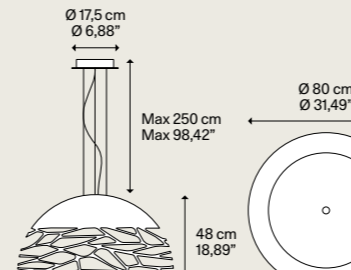

Metal structure
Montatura in metallo

- Matte White - 9010
Bianco Opaco - 9010
- Matte Black - 9005
Nero Opaco - 9005
- Coppery Bronze
Bronzo Ramato
- Matte Champagne
Champagne Opaco

Glass diffuser
Diffusore in vetro

- Glossy White
Bianco Lucido

Code
Codice

- 14128 1000U
- 14128 2000U
- 14128 3500U
- 14128 4500U

Light source
Sorgente luminosa

Medium Base
E26 LED 3x 25 W 120 V
W/L max 12 cm
W/L max 4,72"

Bulb not included
Lampadina non inclusa

Net weight 11,00 kg
Peso netto 24,25 lbs

Boxes 1
Colli 1

Mounts directly to a 4" Standard J-Box

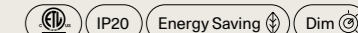

CATEGORY **SUSPENSION LAMP**

DESIGN **Andrea Tosetto, 2015**

Kelly small sphere 40

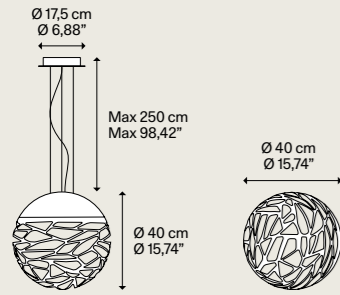

Metal structure Montatura in metallo	Glass diffuser Diffusore in vetro	Code Codice
<ul style="list-style-type: none"> Matte White - 9010 Bianco Opaco - 9010 Coppery Bronze Bronzo Ramato 	<ul style="list-style-type: none"> Glossy White Bianco Lucido 	<ul style="list-style-type: none"> 14122 1000U 14122 3500U

Light source
Sorgente luminosa

Medium Base
E26 LED
3 x 25 W
120 V

W/L max 12 cm
W/L max 4,72"

Bulb not included
Lampadina non inclusa

Net weight 5,50 kg / 12,13 lbs | Boxes Colli 2 | Mounts directly to a 4" Standard J-Box

Energy Saving | Dim

Kelly medium sphere 50

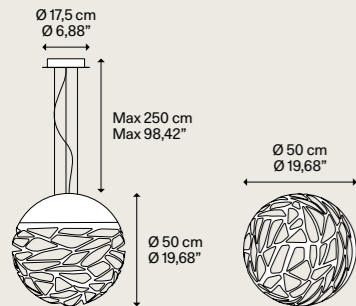

Metal structure Montatura in metallo	Glass diffuser Diffusore in vetro	Code Codice
<ul style="list-style-type: none"> Matte White - 9010 Bianco Opaco - 9010 Coppery Bronze Bronzo Ramato 	<ul style="list-style-type: none"> Glossy White Bianco Lucido 	<ul style="list-style-type: none"> 14123 1000U 14123 3500U

Light source
Sorgente luminosa

Medium Base
E26 LED
3 x 25 W
120 V

W/L max 12 cm
W/L max 4,72"

Bulb not included
Lampadina non inclusa

Net weight 9,00 kg / 19,84 lbs | Boxes Colli 2 | Mounts directly to a 4" Standard J-Box

Energy Saving | Dim

Kelly large sphere 80

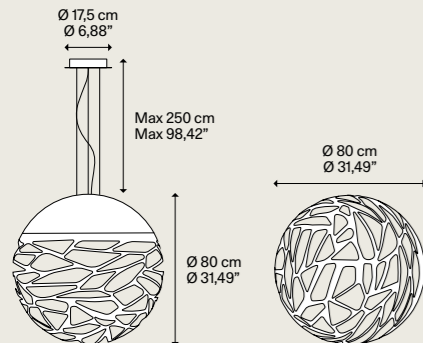

Metal structure Montatura in metallo	Glass diffuser Diffusore in vetro	Code Codice
<ul style="list-style-type: none"> Matte White - 9010 Bianco Opaco - 9010 Coppery Bronze Bronzo Ramato 	<ul style="list-style-type: none"> Glossy White Bianco Lucido 	<ul style="list-style-type: none"> 14124 1000U 14124 3500U

Light source
Sorgente luminosa

Medium Base
E26 LED
3 x 25 W
120 V

W/L max 12 cm
W/L max 4,72"

Bulb not included
Lampadina non inclusa

Net weight 15,00 kg / 33,07 lbs | Boxes Colli 2 | Mounts directly to a 4" Standard J-Box

Energy Saving | Dim

CATEGORY **WALL LAMP**

DESIGN **Andrea Tosetto, 2015**

Kelly

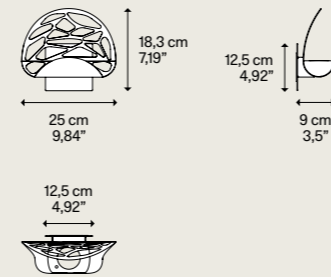

Metal structure Montatura in metallo	Code Codice
<ul style="list-style-type: none"> Matte White - 9010 Bianco Opaco - 9010 Coppery Bronze Bronzo Ramato 	<ul style="list-style-type: none"> 14150 1030U 14150 3530U

Light source
Sorgente luminosa

LED
3000 K
17 W
1800 lm
120 V
CRI 92
MacAdam 3-Step

LED included
LED incluso

Net weight 0,80 kg / 1,76 lbs | Boxes Colli 1 | Mounts directly to a 4" Standard J-Box - Plate Adaptor included *

Energy Saving | Dim Triac

► LED sources with direct power supply to the AC line voltage - driver not required. Dimmable with phase cut dimmer. ► * Recessed backplate available upon request. ► LED con alimentazione diretta a tensione di rete - non necessita di driver. Dimmerabile con varialuce a taglio di fase. ► * Recessed backplate disponibile su richiesta.

Standard Bespoke

Lodes provides functional and decorative solutions that offer endless possibilities for personalisation through the combination of lamps and canopies. The freedom offered by these combinations brings to life the concept of “*Standard Bespoke*”: a collection of products which are universal, meeting the specific needs of any living spaces, thanks to the possibility of configuring unique and meaningful compositions at will.

Lodes consente di creare soluzioni funzionali e decorative che offrono infinite possibilità di personalizzazione grazie all'unione tra lampade e rosoni. La grande libertà offerta da queste combinazioni dà vita al concetto di “*Standard Bespoke*”: una collezione dal carattere universale, in grado di rispondere alle esigenze specifiche di ogni spazio grazie alla possibilità di configurare a piacere composizioni uniche e dense di significato.

Standard Bespoke



Arrangement: Clustered
Type of canopy: 3 lights on a *round canopy*
Finishes: Frosted White, Glossy Smoke and Clear

Cluster suspension lamp



NEW LAMP

Single Canopies



● SINGLE CANOPIES



● SINGLE CANOPIES NORTH AMERICA

Single canopies are ideal for highlighting the corner of a room or enhancing single light sources. They can also be used to create multiple custom combinations on high ceilings or in spaces which do not allow lights to be grouped in a cluster.

I rosoni singoli permettono di mettere in luce gli angoli di una stanza o di valorizzare le singole lampade; possono anche essere utilizzati per creare composizioni multiple e personalizzate su soffitti molto alti o in situazioni che non consentono l'utilizzo di cluster.

Multiple Canopies

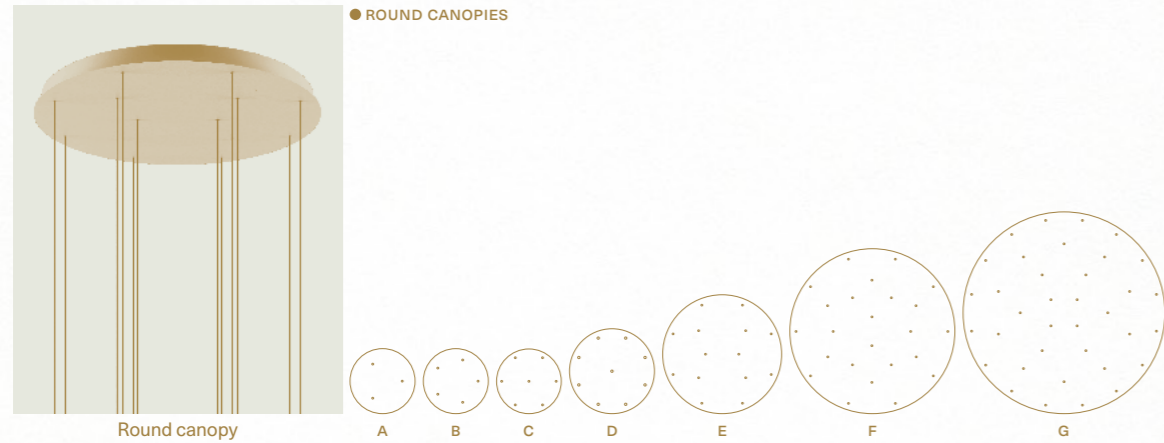

A	3 Lights Round
B	5 Lights Round
C	7 Lights Round
D	9 Lights Round
E	14 Lights Round
F	24 Lights Round
G	36 Lights Round

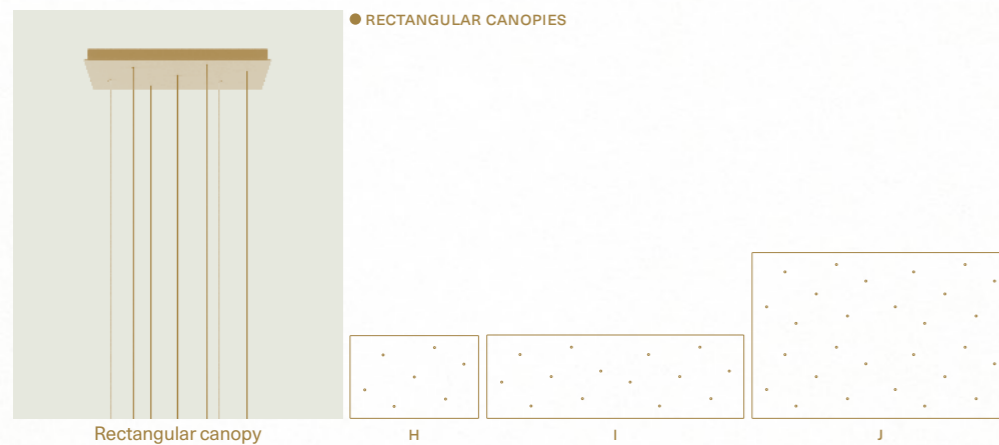

H	7 Lights Rectangular
I	14 Lights Rectangular
J	28 Lights Rectangular

Multiple canopies are the ideal solution for functional and decorative lighting; *round* or *rectangular*, and with a variable but predefined number of holes, they allow the creation of impactful lighting compositions.

I rosoni multipli sono la soluzione ideale per un'illuminazione funzionale e decorativa; *rotondi* o *rettangolari*, e con un numero di fori variabile ma predefinito, permettono di creare composizioni sospese di grande impatto.

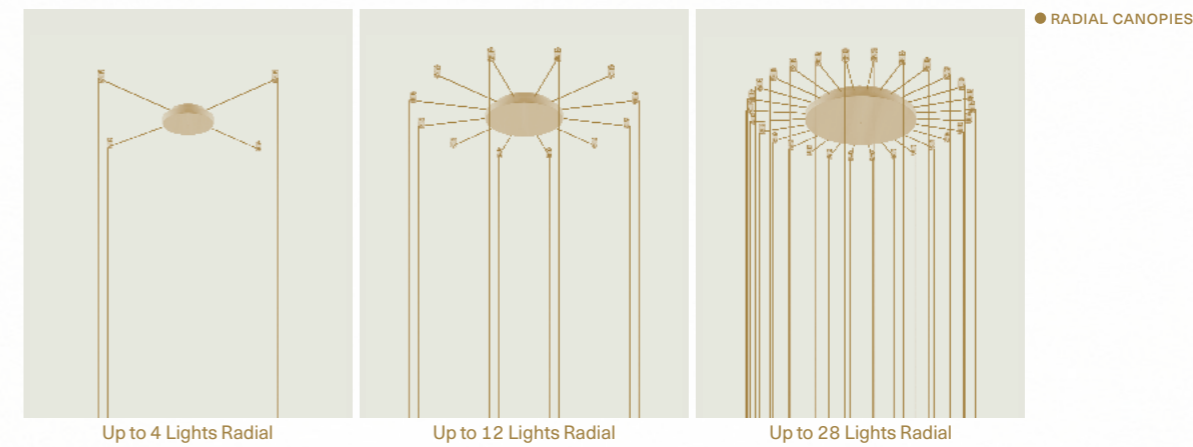

Radial systems are an innovative solution to separately manage various suspension cables with one single canopy, they are the perfect solution to illuminate spaces with irregular ceilings or special rooms.

I sistemi radiali sono una soluzione innovativa per gestire separatamente più cavi di sospensione con un unico rosone; sono la soluzione migliore per illuminare soffitti irregolari o ambienti particolari.

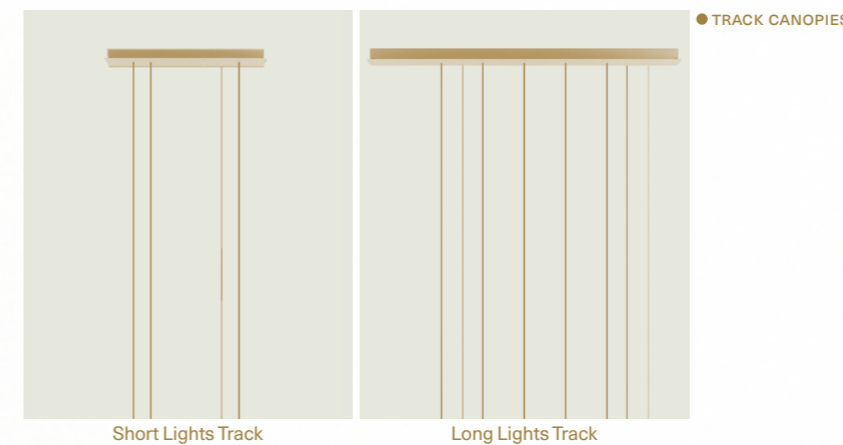

Track systems offer various possibilities for configuration, both in terms of the number of lamps to be included in the composition and the preferred type of installation, for example in projects which require height-aligned or staggered suspended solutions.

I sistemi a binario offrono numerose possibilità di configurazione sia per il numero di lampade da inserire nella composizione, sia in base al tipo di installazione desiderato, come nel caso di progetti che prevedono soluzioni sospese allineate in altezza o sfalsate.

Product Configurator

1



3



2

Lodes' product configurator offers endless opportunities to create personalised canopy lighting. By following a few simple steps – such as selecting a *suspension lamp* and a *canopy* of your choice – it allows to create a unique piece that meets the needs of the space and the desires of the user.

Il configuratore di prodotto Lodes offre infinite possibilità per un'illuminazione personalizzata. Seguendo pochi, semplici passaggi – come selezionare una *lampada* a sospensione e un *rosone* a scelta – permette di configurare un pezzo unico in grado di soddisfare le esigenze dello spazio e i desideri dell'utente.

- 1 Jefferson, Single Standard
- 2 Random Solo, 5 Lights Round
- 3 JIM, 14 Lights Round

VI

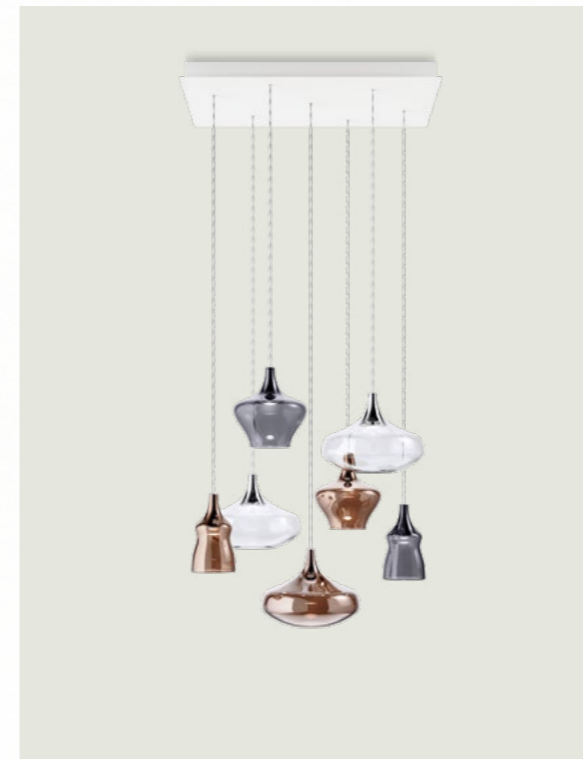

4

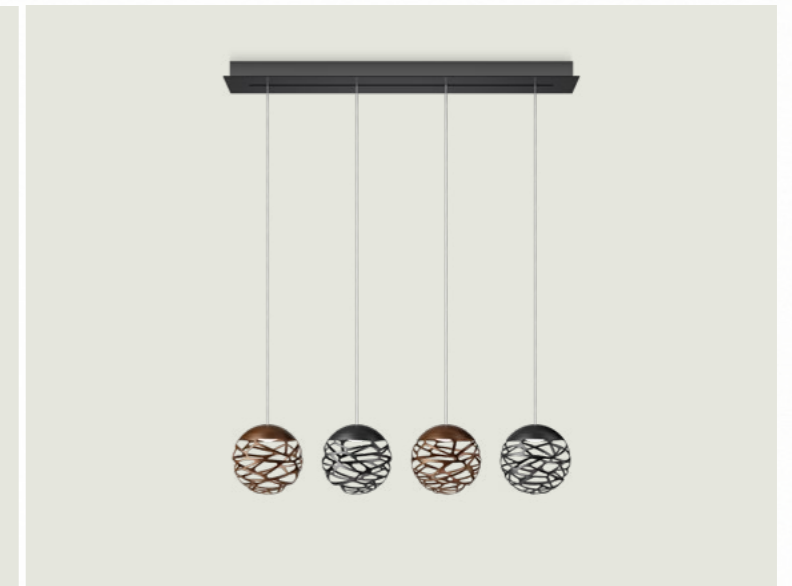

5



6

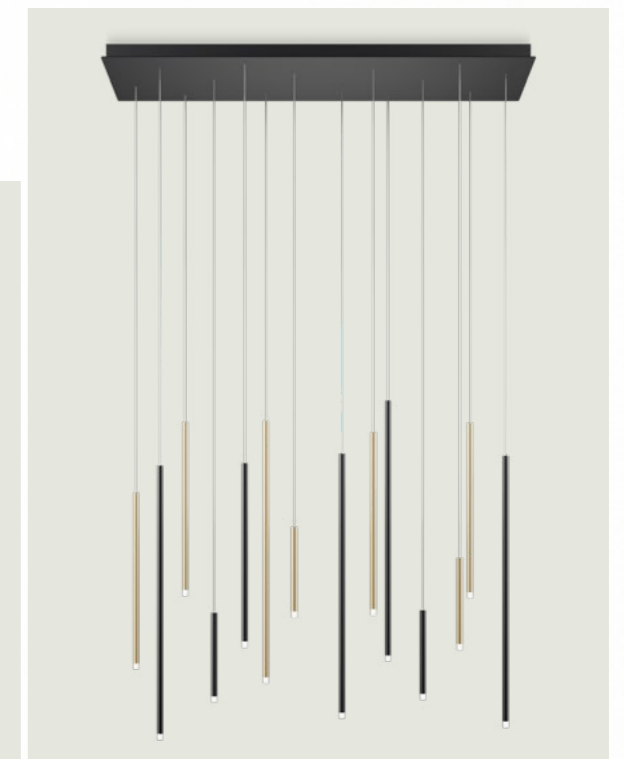

7

- 4 Nostalgia, 7 Lights Rectangular
- 5 Kelly Cluster, Short Lights Track
- 6 Random, Long Lights Track
- 7 A-Tube Nano, 14 Lights Rectangular

VII

The product configurator highlights the *decorative* and *functional* potential of *Lodes'* canopies. Available as single elements or as multiple systems to be installed in any part of a room, *canopies* can be positioned in total freedom, regardless of power source because they are designed to conceal electrical joints. The wide range of possibilities offered by *Lodes* enables the personalization of any environment, whether residential or public, to make individual lamps more original or to make them the protagonists of unique and personalised combinations.

The product configurator embodies the Lodes concept of “Standard bespoke”: *universal yet personalised solutions*, designed according to each client’s technical, functional and decorative needs. The compositions are created from standard elements, the lamps and canopies of the Lodes collections, which can be combined at will by the user through the configurator to create a personal composition.

Il configuratore di prodotto evidenzia il *potenziale decorativo e funzionale* dei rosoni progettati da *Lodes*. Disponibili come elementi singoli o come sistemi multipli da installare in qualsiasi parte della stanza, i *rosoni* possono essere posizionati in totale libertà, indipendentemente dalla fonte di alimentazione perché sono progettati per nascondere i collegamenti elettrici. L'ampia gamma di possibilità offerte da *Lodes* permette di personalizzare qualsiasi ambiente, residenziale o pubblico, per rendere più originali le singole lampade o per farle diventare le protagoniste di combinazioni uniche e personalizzate.

Il configuratore di prodotto definisce il concetto di “Standard Bespoke”: *soluzioni universali ma su misura*, costruite in base alle specifiche esigenze tecniche, funzionali e decorative di ciascun cliente. Le composizioni vengono create a partire da elementi standard, le lampade e i rosoni delle collezioni Lodes, che vengono combinati a piacere dall'utente attraverso il configuratore per creare una soluzione personalizzata.

Lodes' Product Configurator



Create truly unique combinations of light fixtures with Lodes' canopies! Select a lamp, choose your canopy and create your bespoke composition.

Crea combinazioni di luci veramente uniche con i rosoni Lodes! Seleziona una lampada, scegli il tuo rosone e crea la tua composizione personalizzata.

Cono di Luce, *design by* Ron Arad, 2023

Cono di Luce, è un oggetto unico nel suo genere, sintesi del know-how d'avanguardia di Lodes e della creatività firmata Ron Arad. È una lampada caratterizzata da un cono di pirex trasparente che alloggia al suo interno un foglio con un circuito stampato (PCB) e una montatura, anch'essa in PCB. Ulteriore elemento distintivo di *Cono di Luce* è la cornice che personalizza il foglio posto all'interno del cono e che porta il nome del prodotto, la firma del designer e il nome dell'azienda. La lampada pur essendo fortemente caratterizzante, grazie alla sua estetica dal tratto deciso, si inserisce sia in contesti che spaziano da ambienti residenziali a spazi pubblici hospitality piuttosto che food & beverage.

● Spec sheet p. 087

Cono di Luce, is a unique object, a synthesis of Lodes' cutting-edge know-how and Ron Arad's creativity. It's a lamp characterised by a transparent Pyrex cone that houses a printed circuit board (PCB) inside and a frame, also made of PCB. Another distinctive element of *Cono di Luce* is the customisable frame that holds the sheet placed inside the cone, and which bears the name of the product. The frame details both Arad's and Lodes' names. The lamp, while being strongly characterising, fits into contexts ranging from residential settings to public hospitality spaces rather than food & beverage.



CONO DI LUCE	CATEGORY LAMP		TYPE OF LIGHT	
	Suspension Table	Sospensione Tavolo	Diffused light	Luce diffusa

NEW LAMP













1



2

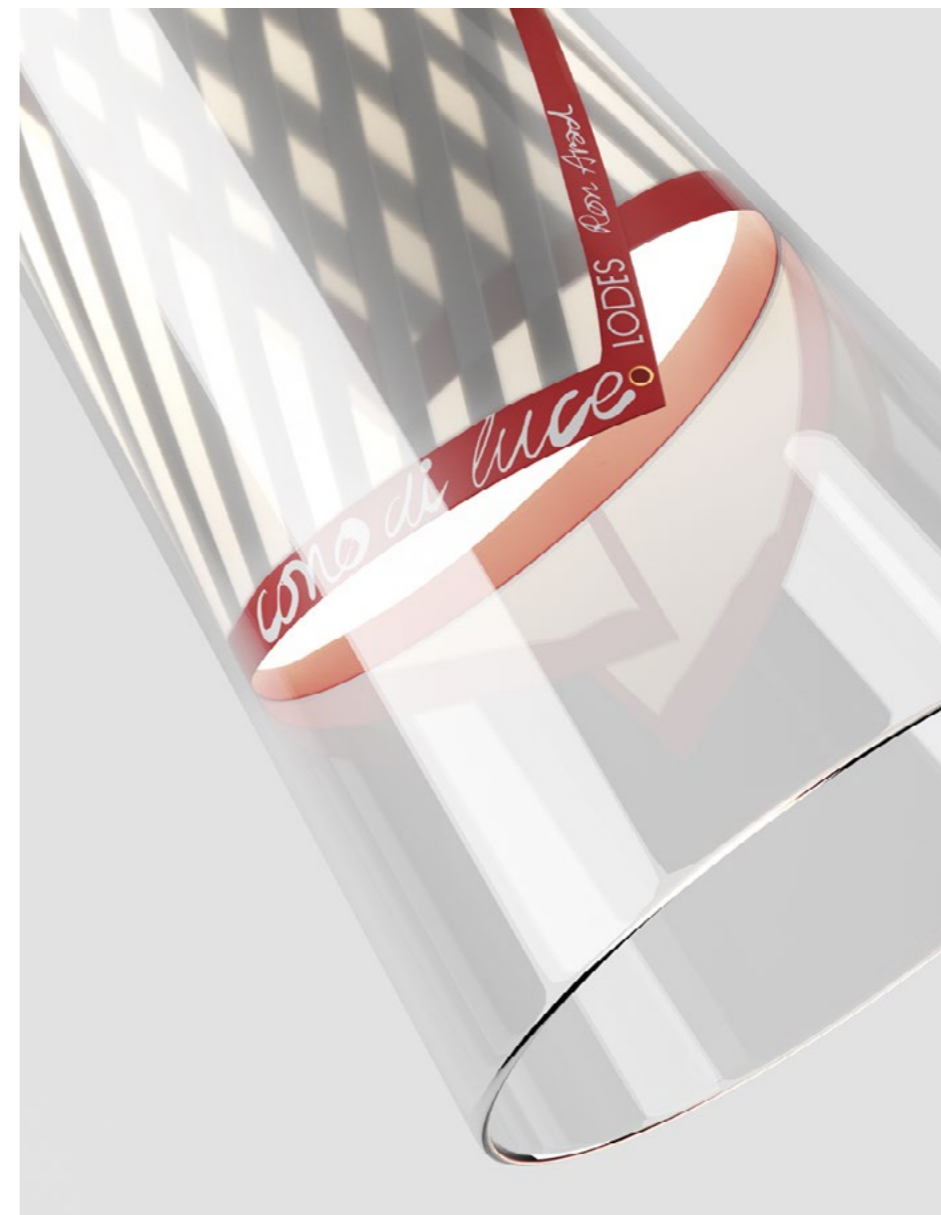

3

1 Cono di Luce, table lamp, FINISH Gold.
 2 Cono di Luce small, FINISH Grey.
 3 Cono di Luce small, FINISH Red.

Cono di Luce, objet unique en son genre, représente la synthèse du savoir-faire avant-gardiste de Lodes et de la créativité de Ron Arad. Cette lampe se caractérise par un cône en Pyrex transparent qui abrite une feuille avec une carte de circuit imprimé (PCB) et une monture, également en PCB. Un autre élément distinctif de *Cono di Luce* est le cadre qui personnalise la feuille placée à l'intérieur du cône et qui porte le nom du produit, la signature du designer et le nom de la société. La lampe, bien que fortement distinctive grâce au caractère décisif de son esthétique, s'intègre dans des contextes allant des environnements résidentiels aux espaces d'accueil publics et à ceux de la restauration. ●FR

Cono di Luce ist ein einzigartiges Objekt, eine Synthese aus Lodes' avantgardistischem Know-how und Ron Arads Kreativität. Es handelt sich um eine Leuchte, die sich durch einen transparenten Pyrex-Kegel auszeichnet, in dessen Innerem sich eine Leiterplatte (PCB) und ein Aufbau, ebenfalls aus PCB, befinden. Ein weiteres charakteristisches Element von *Cono di Luce* ist der Rahmen, der die im Inneren des Kegels platzierte Platte individuell gestaltet und den Produktnamen, die Unterschrift des Designers und den Firmennamen trägt. Auch wenn die Leuchte ausgesprochen charakteristisch ist, fügt sie sich dank ihrer ausgeprägten Ästhetik in Kontexte ein, die von Wohnumgebungen bis hin zu öffentlichen Räumen, Hospitality und Food & Beverage reichen. ●DE

Cono di Luce es un objeto único en su género, la síntesis de los conocimientos técnicos más avanzados de Lodes y la creatividad de Ron Arad. Es una lámpara que se caracteriza por un cono de pyrex transparente que contiene una lámina con un circuito impreso (PCB) y un armazón, también de PCB. Otro elemento característico de *Cono di Luce* es el marco que personaliza la lámina situada dentro del cono y que lleva el nombre del producto, la firma del diseñador y el nombre de la empresa. La lámpara, aun siendo muy reconocible gracias a su estética de trazo decidido, es ideal para contextos que abarcan entornos residenciales, espacios públicos de hostelería e incluso de comida y bebida. ●ES

Cono di Luce – это уникальный в своем роде объект, синтез авангардного ноу-хау Lodes и творческого гения Рона Арада. Эта лампа характеризуется конусом из прозрачного пирекса, внутри которого размещается лист с печатной платой (PCB), и рамой, также изготовленной из PCB. Другим отличительным элементом *Cono di Luce* является обрамление, придающее индивидуальность листу, помещенному внутрь конуса; на нем нанесено название изделия, подпись дизайнера и название компании. Несмотря на ярко выраженные индивидуальные характеристики, благодаря своей решительной эстетике данная лампа легко вписывается в различные контексты, от жилых помещений до общественных, предназначенных для гостиничного и ресторанного бизнеса. ●RU

*Cono di Luce*可谓同类产品中的佼佼者,它将Lodes的尖端技术诀窍以及Ron Arad的设计创造力兼容并蓄。这款灯品的特征在于它那以透明派热克斯玻璃制成的椎体,其内部装有一张带有印刷电路板(PCB)的薄片和一个同样以PCB薄片制成的框架。*Cono di Luce*的另一个与众不同的元素便是檐口,它能使位于椎体内部的薄片做到个性化,薄片上列有产品名称、设计师签名及公司名称。这款灯品尽管特征强烈,但其线条鲜明的美感却使其无论是在住宅环境、酒店公共空间以及餐饮场所内皆可完美搭配。●ZH

Cono di Luce small » Suspension lamp **NEW LAMP**

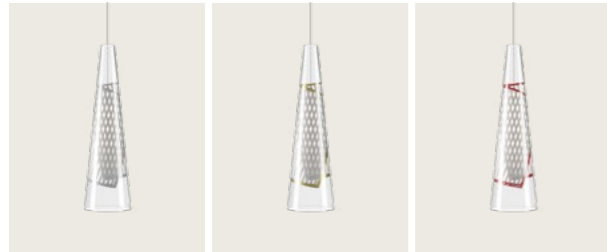

Cono di Luce large » Suspension lamp **NEW LAMP**

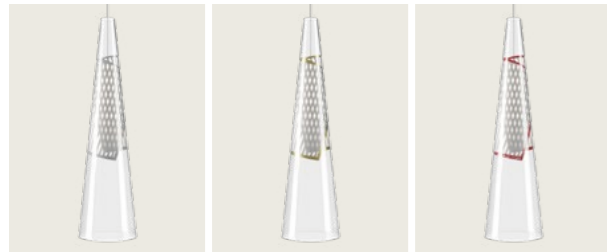

Cono di Luce » Table lamp **NEW LAMP**



CATEGORY **SUSPENSION LAMP**

Cono di Luce small **NEW**

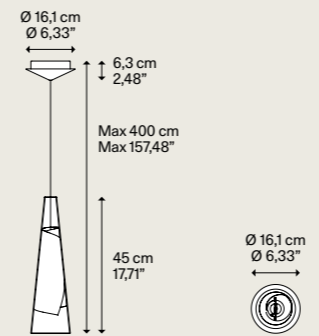

Net weight 1,21 kg / 2,66 lbs
Boxes 3 / Colli 3

Cono di Luce large **NEW**

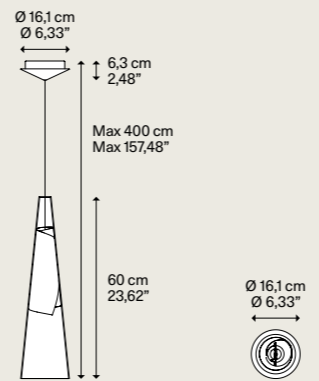

Net weight 1,60 kg / 3,52 lbs
Boxes 3 / Colli 3

CATEGORY **TABLE LAMP**

Cono di Luce **NEW**

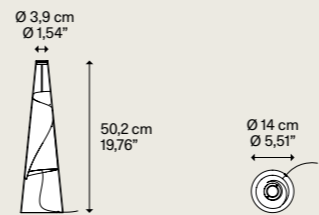

Net weight 0,91 kg / 2,00 lbs
Boxes 2 / Colli 2

DESIGN Ron Arad, 2023

Outside blown glass diffuser
Diffusore esterno in vetro soffiato

Clear
Trasparente

Light source
Sorgente luminosa

LED 2700 K
11 W
1307 lm
350 mA
CRI 90
MacAdam 3-Step

LED and driver included
LED e driver inclusi

Inside PCB diffuser
Diffusore interno in PCB

Grey
Grigio

Gold
Oro

Red
Rosso

Code
Codice

21020 3227U

21020 5027U

21020 6027U

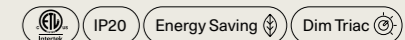

Outside blown glass diffuser
Diffusore esterno in vetro soffiato

Clear
Trasparente

Light source
Sorgente luminosa

LED 2700 K
11 W
1307 lm
350 mA
CRI 90
MacAdam 3-Step

LED and driver included
LED e driver inclusi

Inside PCB diffuser
Diffusore interno in PCB

Grey
Grigio

Gold
Oro

Red
Rosso

Code
Codice

21021 3227U

21021 5027U

21021 6027U

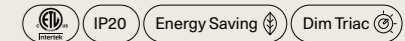

DESIGN Ron Arad, 2023

Outside blown glass diffuser
Diffusore esterno in vetro soffiato

Clear
Trasparente

Light source
Sorgente luminosa

LED 2700 K
7,5 W
1307 lm
5 V / 1,5 A
CRI 90
MacAdam 3-Step

LED, driver and touch dimmer included
LED, driver e touch dimmer inclusi

Inside PCB diffuser
Diffusore interno in PCB

Grey
Grigio

Gold
Oro

Red
Rosso

Code
Codice

21080 3227U

21080 5027U

21080 6027U

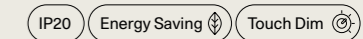

Volum, design by Snøhetta, 2022/2023

Volum is an exclusive series of glass lamps that are poetically simple yet complex in their technically execution. The four blown glass globes with glossy white finish come in different sizes measuring 14, 22, 29 and 42 cm in diameter. Thanks to their inherently distinct shapes, they intuitively complement one another to form unique compositions. Enhanced by a fluid and discreet design, each Volum globe features a glossy white diffuser that lets light pass through evenly like glass does. The collection includes several functions: suspension cluster suspension, ceiling, wall and table versions, further exploring the concept of 360° lighting.

● Spec sheet p. 106

Volum è una serie esclusiva di lampade in vetro poeticamente semplici seppur complesse nella loro realizzazione tecnica. Le quattro sfere in vetro soffiato, caratterizzate da una finitura bianca lucida, hanno dimensioni diverse che misurano 14, 22, 29 e 42 cm (diametro). Grazie alle loro forme intrinsecamente distinte si completano intuitivamente per creare composizioni uniche. Valorizzata da un design fluido e discreto, ciascuna sfera Volum è dotata di un diffusore con finitura bianca lucida che lascia passare la luce in modo uniforme come il vetro. La collezione include varie funzioni: sospensione, sospensione cluster, soffitto, parete e tavolo, che esplorano il concetto di illuminazione dello spazio a 360°.

VOLUM	CATEGORY LAMP	TYPE OF LIGHT
	Cluster suspension Suspension Wall Ceiling Table	Sospensione cluster Sospensione Parete Soffitto Tavolo
		Diffused light Luce diffusa



089 Cluster suspension lamp, Wall lamp, Table lamp Volum 29 cluster suspension lamp, Volum 14, 22 wall lamp and Volum 14, 22, 29 and 42 table lamp, FINISH Glossy White. Volum





1



093

Cluster suspension lamp

Volum

1 Volum, the methacrylate lid lets light through the same way as the glass.
 2 Volum 14, 22 and 29, 2 × composition of 3 lights on a *round canopy* and single lights on *recessed micro canopies*, FINISH Glossy White.



1

1 Volum 29, 22, 14 and 42, FINISH Glossy White.
 2 Volum 42, FINISH Glossy White.



2





1



2

1 Volum 14, 22, 29 and 42 table lamp, FINISH Glossy White.
 2 Volum table lamp, translucent silicone base.



1

1 Volum 22 wall and table lamp, FINISH Glossy White.
 2 Volum 14, 22 table lamp and Volum 22 cluster suspension lamp, FINISH Glossy White.



2

101

Cluster suspension lamp, Wall lamp, Table lamp

Volum



1



2



3

1, 2 Volum wall lamp, translucent silicone structure.
3 Volum mirror 22 wall lamp, FINISH Glossy White.



Volum est une série exclusive de lampes en verre, d'une simplicité poétique mais complexe dans leur conception technique. Les quatre sphères en verre soufflé, caractérisées par une finition blanc brillant, présentent un diamètre différent de 14, 22, 29 et 42 cm. Grâce à leurs formes intrinsèquement différentes, elles se complètent intuitivement pour créer des compositions uniques. Sublimée par un design fluide et discret, chaque sphère *Volum* est dotée d'un diffuseur avec finition blanc brillant qui laisse passer la lumière aussi uniformément que du verre. La collection présente différentes fonctions : suspension, suspension en cluster, plafonnier, applique et lampe de table, qui explorent le concept d'éclairage de l'espace à 360°. ● FR

Volum ist eine exklusive Serie von Glasleuchten, die poetisch einfach und doch komplex in ihrer technischen Umsetzung sind. Die vier mundgeblasenen Glaskugeln, die sich durch eine glänzende weiße Ausführung auszeichnen, haben unterschiedliche Abmessungen von 14, 22, 29 und 42 cm (Durchmesser). Dank ihrer von Natur aus unterschiedlichen Formen ergänzen sie sich intuitiv und ermöglichen es somit, einzigartige Kompositionen zu kreieren. Aufgewertet durch ein harmonisches und diskretes Design, verfügt jede *Volum*-Kugel über einen Diffusor mit weißer Hochglanzoberfläche, der das Licht gleichmäßig wie Glas durchscheinen lässt. Die Kollektion umfasst verschiedene Funktionen: Hängeleuchten, Cluster, Decken-, Wand- und Tischleuchten, die das Konzept der 360°-Beleuchtung des Raums erforschen. ● DE

Volum es una serie exclusiva de lámparas de vidrio poéticamente sencillas a pesar de ser complejas por lo que respecta a su ejecución técnica. Las cuatro esferas de vidrio soplado, caracterizadas por un acabado blanco brillante, tienen distintos tamaños que miden 14, 22, 29 y 42 cm (diámetro). Gracias a sus formas intrínsecamente distintas se completan intuitivamente para crear composiciones únicas. Mejorada con un diseño fluido y discreto, cada esfera *Volum* cuenta con un difusor con acabado blanco brillante que deja pasar la luz de manera uniforme como el vidrio. La colección incluye varias funciones: colgantes, grupos de lámparas colgantes, de techo, pared y sobremesa, que exploran el concepto de iluminación del espacio a 360°. ● ES

Volum – это эксклюзивная серия стеклянных светильников, поэтически простых и, одновременно, сложных в техническом исполнении. Четыре сферы из выдувного стекла с блестящей белой отделкой имеют разные размеры: 14, 22, 29 и 42 см (в диаметре). Благодаря своим характерным формам эти сферы интуитивно дополняют друг друга, создавая уникальные композиции. Каждая сфера *Volum*, отличающаяся текучим и сдержанным дизайном, оснащена диффузором с блестящей белой отделкой, равномерно пропускающим свет как и стекло. Коллекция включает различные функциональные лампы: подвесные, подвесные кластерные, потолочные, настенные и настольные, которые раскрывают концепцию освещения пространства на 360°. ● RU

Volum 是一款独一无二的玻璃灯系列，其技术构造在诗意般简约的同时亦是完备无缺的。四只吹制玻璃球体以亮光白色饰面为其特征，具有分别为14、22、29和42厘米(直径)的不同尺寸。得益于其本质上各不相同的形状，它们能够直观地相互补充，以创造独特的组合。流畅谨慎的设计为其赋予价值，每只*Volum*球体都被一只亮白色灯罩所封闭，使光线能够像玻璃一样均匀穿过。该系列包含功能各异的灯品：悬吊灯、组合悬吊灯、吸顶灯、壁灯和台灯，所有这些功能都在探索着对空间进行360度照明的理念。● ZH

Volum 14, 22, 29 ↘ Cluster suspension lamp



Volum 42 ↘ Suspension lamp



Volum 14, 22, 29, 42 ↘ Table lamp



Volum 14, 22, 29, 42 ↘ Ceiling lamp, Wall lamp

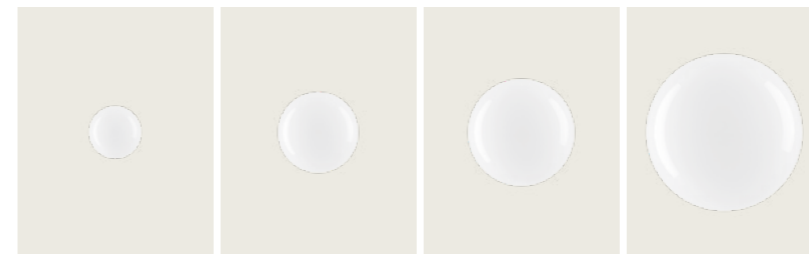

CATEGORY CLUSTER SUSPENSION LAMP

DESIGN Snøhetta, 2022

Volum 14

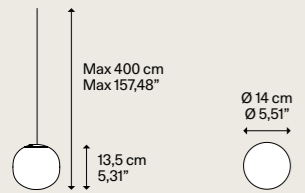

Net weight 0,90 kg / 1,98 lbs
Boxes Colli 2

Methacrylate structure
Struttura in metacrilato

Glossy White
Bianco Lucido

Light source
Sorgente luminosa

Candelabra base E12
15 W 120 V
W/L max 8 cm / W/L max 3,14"
Ø max 6 cm / Ø max 2,36"

Bulb not included
Lampadina non inclusa

Blown glass diffuser
Diffusore in vetro soffiato

Glossy White
Bianco Lucido

IP20

Code
Codice

18711 1200U

Volum 22

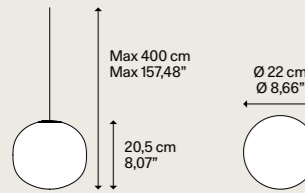

Net weight 1,30 kg / 2,86 lbs
Boxes Colli 2

Methacrylate structure
Struttura in metacrilato

Glossy White
Bianco Lucido

Light source
Sorgente luminosa

Medium Base E26
1 x 25 W 120 V
W/L max 11 cm / W/L max 4,33"
Ø max 6 cm / Ø max 2,36"

Bulb not included
Lampadina non inclusa

Blown glass diffuser
Diffusore in vetro soffiato

Glossy White
Bianco Lucido

IP20

Code
Codice

18712 1200U

Volum 29

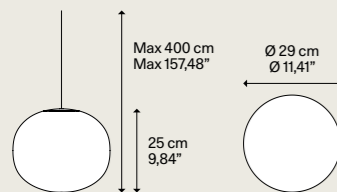

Net weight 2,12 kg / 4,67 lbs
Boxes Colli 2

Methacrylate structure
Struttura in metacrilato

Glossy White
Bianco Lucido

Light source
Sorgente luminosa

Medium Base E26
1 x 25 W 120 V
Ø max 9,8 cm / Ø max 3,74"

Bulb not included
Lampadina non inclusa

Blown glass diffuser
Diffusore in vetro soffiato

Glossy White
Bianco Lucido

IP20

Code
Codice

18713 1200U

Suspension lamps must be installed on a canopy ▶ p. 426-433
Le lampade a sospensione devono essere installate su rosone ▶ p. 426-433

CATEGORY SUSPENSION LAMP

DESIGN Snøhetta, 2022

Volum 42

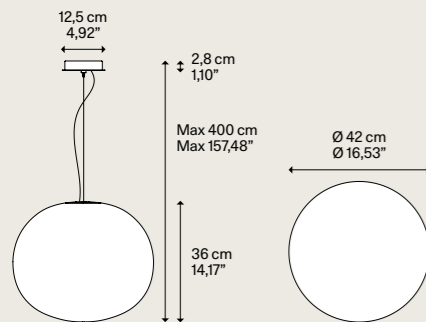

Net weight 3,64 kg / 8,02 lbs
Boxes Colli 2
Mounts directly to a 4" Standard J-Box

Methacrylate structure
Struttura in metacrilato

Glossy White
Bianco Lucido

Light source
Sorgente luminosa

Medium Base E26
1 x 25 W 120 V
Ø max 9,8 cm / Ø max 3,74"

Bulb not included
Lampadina non inclusa

Blown glass diffuser
Diffusore in vetro soffiato

Glossy White
Bianco Lucido

IP20

Code
Codice

18720 1200U

CATEGORY TABLE LAMP

DESIGN Snøhetta, 2023

Volum 14

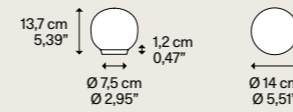

Net weight 0,80 kg / 1,76 lbs
Boxes Colli 2

Silicone base
Base in silicone

Translucent
Traslucido

Light source
Sorgente luminosa

Candelabra base E12
15 W 120 V
W/L max 9 cm / W/L max 3,54"
Ø max 6 cm / Ø max 2,36"

Bulb not included
Lampadina non inclusa
ON/OFF Switch the cord
Interuttore ON/OFF sul cavo

IP20

Code
Codice

18781 1200U

Volum 22

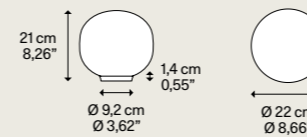

Net weight 1,26 kg / 2,77 lbs
Boxes Colli 2

Silicone base
Base in silicone

Translucent
Traslucido

Light source
Sorgente luminosa

Medium Base E26
1 x 25 W 120 V
W/L max 12,5 cm / W/L max 4,92"
Ø max 6 cm / Ø max 2,36"

Bulb not included
Lampadina non inclusa
ON/OFF Switch the cord
Interuttore ON/OFF sul cavo

IP20

Code
Codice

18782 1200U

Volum 29

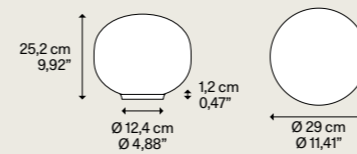

Net weight 2,16 kg / 4,76 lbs
Boxes Colli 2

Silicone base
Base in silicone

Translucent
Traslucido

Light source
Sorgente luminosa

Medium Base E26
1 x 25 W 120 V
Ø max 9,8 cm / Ø max 3,85"

Bulb not included
Lampadina non inclusa
ON/OFF Switch the cord
Interuttore ON/OFF sul cavo

IP20

Code
Codice

18783 1200U

Volum 42

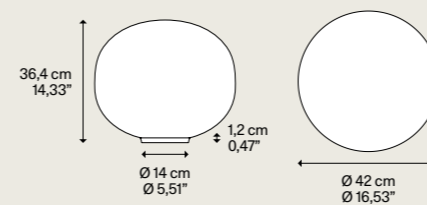

Net weight 3,44 kg / 7,58 lbs
Boxes Colli 2

Silicone base
Base in silicone

Translucent
Traslucido

Light source
Sorgente luminosa

Medium Base E26
1 x 25 W 120 V
Ø max 9,8 cm / Ø max 3,85"

Bulb not included
Lampadina non inclusa
ON/OFF Switch the cord
Interuttore ON/OFF sul cavo

IP20

Code
Codice

18784 1200U

CATEGORY WALL LAMP

DESIGN Snøhetta, 2023

Volum mirror 14

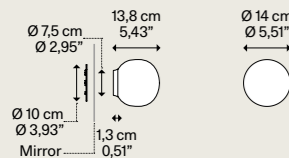

Net weight 0,74 kg / 1,63 lbs
Boxes Colli 2

Silicone structure Struttura in silicone	Blown glass diffuser Diffusore in vetro soffiato	Code Codice
Translucent Traslucido	Glossy White Bianco Lucido	18741 120SU

**Light source
Sorgente luminosa**
Candelabra base E12
15 W 120 V
W/L max 9 cm / W/L max 3,54"
Ø max 5 cm / Ø max 1,96"
Bulb not included
Lampadina non inclusa

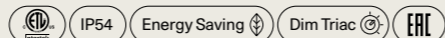

Volum mirror 22

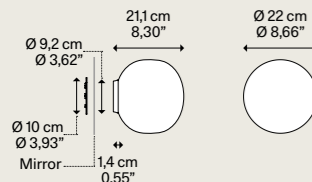

Net weight 1,15 kg / 2,53 lbs
Boxes Colli 2

Silicone structure Struttura in silicone	Blown glass diffuser Diffusore in vetro soffiato	Code Codice
Translucent Traslucido	Glossy White Bianco Lucido	18742 120SU

**Light source
Sorgente luminosa**
Medium Base E26
1 x 25 W 120 V
W/L max 12,5 cm / W/L max 4,92"
Ø max 5 cm / Ø max 1,96"
Bulb not included
Lampadina non inclusa

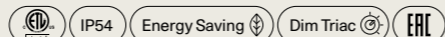

Volum mirror 29

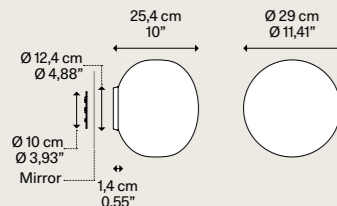

Net weight 2,16 kg / 4,76 lbs
Boxes Colli 2

Silicone structure Struttura in silicone	Blown glass diffuser Diffusore in vetro soffiato	Code Codice
Translucent Traslucido	Glossy White Bianco Lucido	18743 120SU

**Light source
Sorgente luminosa**
Medium Base E26
1 x 25 W 120 V
Ø max 8,5 cm / Ø max 3,34"
Bulb not included
Lampadina non inclusa

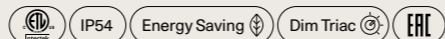

Volum mirror 42

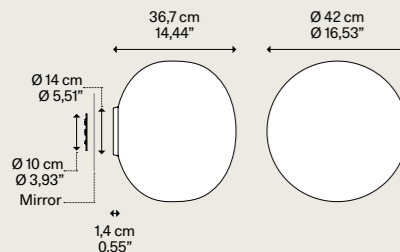

Net weight 3,39 kg / 7,47 lbs
Boxes Colli 2

Silicone structure Struttura in silicone	Blown glass diffuser Diffusore in vetro soffiato	Code Codice
Translucent Traslucido	Glossy White Bianco Lucido	18744 120SU

**Light source
Sorgente luminosa**
Medium Base E26
1 x 25 W 120 V
Ø max 8,5 cm / Ø max 3,34"
Bulb not included
Lampadina non inclusa

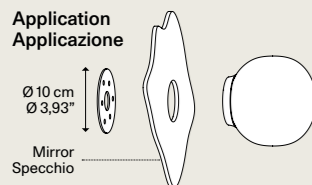
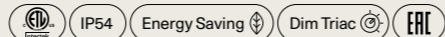

CATEGORY WALL LAMP CEILING LAMP

DESIGN Snøhetta, 2023

Volum 14

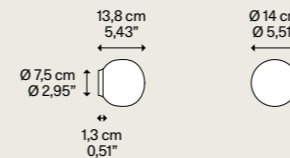

Net weight 0,74 kg / 1,63 lbs
Boxes Colli 2

Mounts directly to a 4" Standard J-Box - Plate Adaptor included *

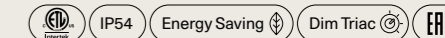

Silicone structure Struttura in silicone	Blown glass diffuser Diffusore in vetro soffiato	Code Codice
Translucent Traslucido	Glossy White Bianco Lucido	18741 1200U

**Light source
Sorgente luminosa**
Candelabra base E12
15 W 120 V
W/L max 9 cm / W/L max 3,54"
Ø max 5 cm / Ø max 1,96"
Bulb not included
Lampadina non inclusa

Volum 22

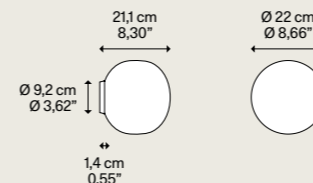

Net weight 1,15 kg / 2,53 lbs
Boxes Colli 2

Mounts directly to a 4" Standard J-Box - Plate Adaptor included *

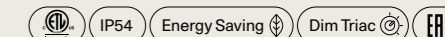

Silicone structure Struttura in silicone	Blown glass diffuser Diffusore in vetro soffiato	Code Codice
Translucent Traslucido	Glossy White Bianco Lucido	18742 1200U

**Light source
Sorgente luminosa**
Medium Base E26
1 x 25 W 120 V
W/L max 12,5 cm / W/L max 4,92"
Ø max 5 cm / Ø max 1,96"
Bulb not included
Lampadina non inclusa

Volum 29

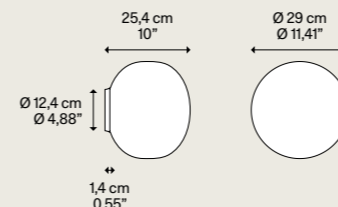

Net weight 2,16 kg / 4,76 lbs
Boxes Colli 2

Mounts directly to a 4" Standard J-Box

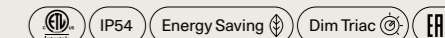

Silicone structure Struttura in silicone	Blown glass diffuser Diffusore in vetro soffiato	Code Codice
Translucent Traslucido	Glossy White Bianco Lucido	18743 1200U

**Light source
Sorgente luminosa**
Medium Base E26
1 x 25 W 120 V
Ø max 8,5 cm / Ø max 3,34"
Bulb not included
Lampadina non inclusa

Volum 42

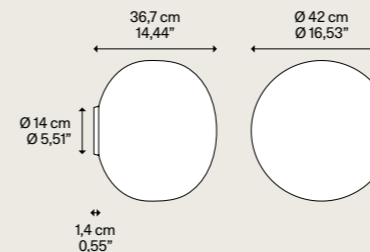

Net weight 3,39 kg / 7,47 lbs
Boxes Colli 2

Mounts directly to a 4" Standard J-Box

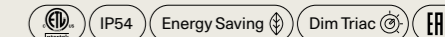

Silicone structure Struttura in silicone	Blown glass diffuser Diffusore in vetro soffiato	Code Codice
Translucent Traslucido	Glossy White Bianco Lucido	18744 1200U

**Light source
Sorgente luminosa**
Medium Base E26
1 x 25 W 120 V
Ø max 8,5 cm / Ø max 3,34"
Bulb not included
Lampadina non inclusa

Random, *design by Chia-Ying Lee, 2017*

A lightweight, blown glass suspension light, *Random* is made up of three round diffusers of different sizes which form one simple, eye-catching whole. Each diffuser has an LED light source which emits warm white light. When grouped together on a cluster, *Random* light fixtures form a poetic composition like soap bubbles, enhanced by the glossy coloured finishes which add a touch of character and originality.

● Spec sheet p. 129

Leggerissima lampada a sospensione in vetro soffiato, *Random* è composta da tre diffusori sferici di dimensioni diverse che formano un'entità semplice e vivace. Ogni diffusore è dotato di una sorgente luminosa a LED che fornisce una calda luce bianca. Raggruppate su cluster le lampade *Random* danno vita a composizioni poetiche come giochi di bolle di sapone, che le finiture lucide sfumate arricchiscono di carattere e originalità.



RANDOM	CATEGORY LAMP		TYPE OF LIGHT	
	Cluster suspension	Sospensione cluster	Diffused light	Luce diffusa







Random, special composition of 14 lights on recessed micro canopies, FINISH Frosted White.

115 Cluster suspension lamp

Random, special composition of 14 lights
on *recessed micro canopies*, FINISH Frosted White.







2







Clear

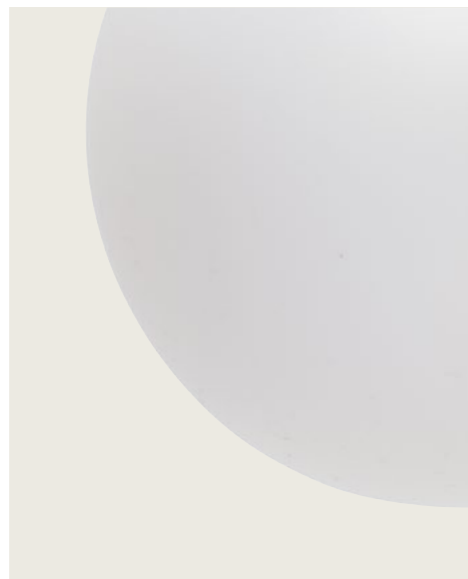

Frosted White



Chrome



Glossy Smoke



Glossy Bronze



Gold

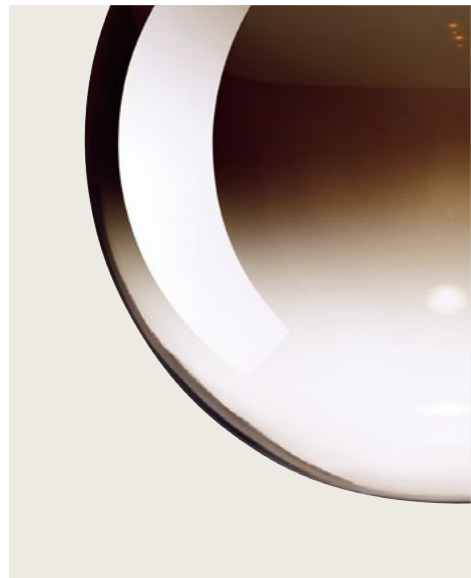

Rose Gold



Suspension très légère en verre soufflé, *Random* est composée de trois diffuseurs sphériques de différentes tailles formant une entité simple et vivante. Chaque diffuseur est équipé d'une source lumineuse LED qui fournit une lumière blanche chaude. Regroupées en cluster, les lampes *Random* donnent vie à des compositions poétiques telles que des jeux de bulles de savon, dont les finitions douces et ombragées enrichissent le caractère et l'originalité. ●FR

Random ist eine ultraleichte Hängeleuchte aus geblasenem Glas und besteht aus drei kugelförmigen Diffusoren in unterschiedlicher Größe, die eine einfache und lebhaft Einheit bilden. Jeder Diffusor verfügt über eine LED-Lichtquelle, die warmweißes Licht abstrahlt. In Clustern angeordnet, lassen die Leuchten *Random* poetische Kombinationen entstehen, die einem Spiel aus Seifenblasen ähneln und denen die glänzenden, nuancierten Ausführungen Charakter und Originalität verleihen. ●DE

Lámpara muy ligera colgante de vidrio soplado, *Random* está compuesta de tres difusores esféricos de diferentes dimensiones que forman una entidad simple y dinámica. Cada difusor está equipado con una fuente luminosa de LED que proporciona una luz blanca cálida. Reagrupadas en grupos de lámparas colgantes *Random* dan vida a composiciones poéticas como juegos de pompas de jabón, que los acabados brillantes matizados enriquecen con carácter y originalidad. ●ES

Random – это легкий подвесной светильник из выдувного стекла, состоящий из трех сферических диффузоров разных размеров, которые образуют простую и живую композицию. Каждый диффузор оснащен светодиодным источником теплого белого света. Объединенные в кластеры лампы *Random* дают жизнь восхитительным композициям, таким как игра мыльных пузырей, а глянцевая отделка придает им своеобразный характер и оригинальность. ●RU

Random 是一款非常轻盈的吹制玻璃吊灯，由三个不同尺寸的球形灯罩组成，形成简单活泼的整体。每一个灯罩都配有一个LED光源，提供白色的温暖灯光。集中在组合吊上，*Random*灯可形成诗意的组合，如同肥皂泡的嬉戏，光亮的色泽丰富了个性与原创性。●ZH

CATEGORY CLUSTER SUSPENSION LAMP

Random

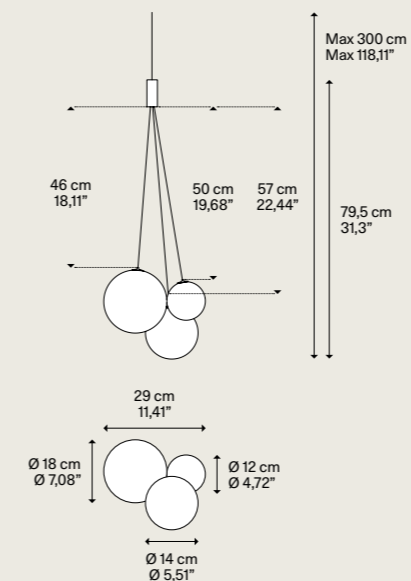

DESIGN Chia-Ying Lee, 2017

Metal structure
Montatura in metallo

Chrome Cromo

Blown glass diffuser
Diffusore in vetro soffiato

	Code Codice ^A	Code Codice ^B
Clear Trasparente	16410 0020U	16410 0035U
Frosted White Bianco Satinato	16410 1320U	16410 1335U
Chrome Cromo	16410 4020U	16410 4035U
Glossy Smoke Fumo Lucido	16410 4320U	16410 4335U
Glossy Bronze Bronzo Lucido	16410 4620U	16410 4635U
Gold Oro	16410 5020U	16410 5035U
Rose Gold Oro Rosa	16410 5520U	16410 5535U

Light source
Sorgente luminosa

LED
2700 K
4 W
450 lm
350 mA
CRI 90
MacAdam 3-Step
LED included
LED incluso

Light source
Sorgente luminosa

LED
3000 K
4 W
480 lm
350 mA
CRI 90
MacAdam 3-Step
LED included
LED incluso

Net weight 1,00 kg / 2,20 lbs | Boxes Colli 2

IP20 | Energy Saving | Dim Triac

Suspension lamps must be installed on a canopy ▶ p. 434-441
Le lampade a sospensione devono essere installate su rosone ▶ p. 434-441

Random ▶ Cluster suspension lamp

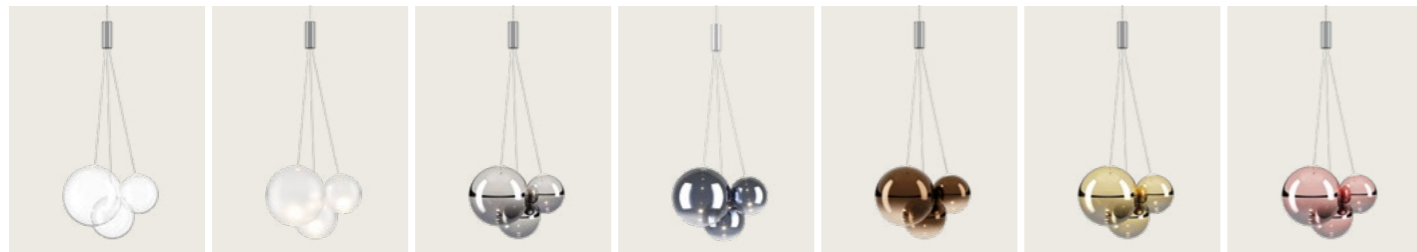

Random Solo, *design by Chia-Ying Lee, 2020/2024*

Six perfect spheres floating in the air like gentle glass bubbles. *Random Solo* revisits the concept of the *Random* suspension lamp by parting the original three-piece cluster and releasing the individuality of the spherical shapes, which float like bubbles of light, letting you imagine compositions of luminous harmonies. Thanks to the new 10 cm size, there are now six dimensions and seven different finishes available, offering ample styling freedom, both as individually suspended light points and in lightweight and lively combinations on clusters.

● Spec sheet p. 147

Sei sfere perfette che fluttuano nell'aria come leggere bolle di vetro. *Random Solo* rivisita il concetto della lampada a sospensione *Random*, separando l'originale cluster a tre elementi e liberando l'individualità delle forme sferiche, che fluttuano come bolle di luce lasciando immaginare composizioni di armonie luminose. Grazie alla nuova sfera da 10 cm, sono ora sei le dimensioni e sette le finiture disponibili, offrendo ampia libertà di arredamento, sia come punti luce sospesi singolarmente che in leggere e vivaci composizioni multiple su cluster.



RANDOM SOLO	CATEGORY LAMP		TYPE OF LIGHT	
	Cluster suspension	Sospensione cluster	Diffused light	Luce diffusa

NEW LAMP





1

1 Random Solo, FINISHES Glossy Smoke and Clear.
 2 Random Solo 23 and 28, composition of 14 lights on a round canopy, FINISHES Clear and Glossy Smoke.



2

133

Cluster suspension lamp

Random Solo



Random Solo 10, 12, 14, 18, 23 and 28, special composition of 142 lights on recessed micro canopies, FINISHES Clear, Glossy Bronze and Chrome.



Random Solo, composition of 14 lights on a *round canopy*, FINISHES Glossy Bronze and Clear.



Random Solo, composition on *round canopies* and single lights on *single canopies*, FINISHES Chrome and Clear.

Clustersuspension lamp

Random Solo



Random Solo 14, 23 and 28, composition of 5 lights on a *round canopy* and single lights on *single mini canopies*, FINISHES Clear and Rose Gold.



1



143

Cluster suspension lamp

Random Solo

1 Random Solo, FINISH Frosted White.
 2 Random Solo 23, composition of 4 lights on a *long track*, FINISH Frosted White.



Clear



Frosted White



Chrome



Glossy Smoke



Glossy Bronze



Gold



Rose Gold

Six sphères parfaites flottant dans l'air comme de suaves bulles de verre. *Random Solo* revisite le concept de la suspension *Random* en séparant le cluster original de trois pièces et en libérant l'individualité des formes sphériques qui fluctuent comme des bulles de lumière faisant imaginer des compositions d'harmonies lumineuses. Avec la nouvelle sphère de 10 cm, nous sommes ravis de pouvoir proposer six tailles et sept finitions pour une grande liberté d'ameublement, tant comme points lumineux suspendus individuellement qu'en combinaisons légères et animées en cluster. ●FR

Sechs perfekte Kugeln, die wie leichte Glasblasen in der Luft schweben. *Random Solo* überarbeitet das Konzept der Hängeleuchte *Random*, für das das Original-Cluster mit drei Elementen aufgeteilt wurde, und die Individualität der sphärischen Formen freisetzt, die wie Lichtblasen schweben und Kompositionen aus leuchtenden Harmonien erahnen lassen. Dank der neuen 10-cm-Kugel stehen nun sechs Größen und sieben verschiedene Ausführungen zur Verfügung, die eine große Gestaltungsfreiheit bieten, sowohl als einzeln aufgehängte Lichtpunkte als auch in leichten und lebhaften Kombinationen auf Clustern. ●DE

Seis esferas perfectas que flotan en el aire como delicadas burbujas de vidrio. *Random Solo* reexamina el concepto de la lámpara de suspensión *Random* separando el grupo de lámparas de suspensión original y liberando la individualidad de las formas esféricas que flotan como burbujas de luz y dejan imaginar composiciones de armonías luminosas. Gracias a la nueva esfera de 10 cm, ahora hay seis tamaños y siete acabados disponibles que ofrecen una amplia libertad de decoración, tanto como puntos de luz suspendidos individualmente como en composiciones múltiples ligeras y alegres en grupos de lámparas de suspensión. ●ES

Шесть идеальных сфер, парящих в воздухе подобно нежным стеклянным пузырям. *Random Solo* по-новому осмысливает концепцию подвесного светильника *Random*, разделяя оригинальный кластер, состоящий из трех частей, и освобождая индивидуальность сферических форм, парящих как светящиеся шары и вызывая в воображении гармоничные световые композиции. Благодаря новой сфере размером 10 см, предлагаются шесть размеров и семь отделок, гарантируя огромную свободу по оформлению декора, как в качестве индивидуально подвешенных световых точек, так и в легких и ярких комбинациях в кластерах. ●RU

六个完美的球体就像柔和的玻璃泡泡一般漂浮于空中。*Random Solo*重新审视了*Random*悬吊灯的理念,将最初的三件式底盘分开而来并为球体形状留下了更多的个体空间,这些球体像光的泡泡一样漂浮着,令人联想至光影交融的和谐组合。得益于10厘米的全新球体,六种尺寸和七种饰面如今提供充足的造型自由度,既可作为单独悬吊的照明点,亦可作为轻盈活泼的底盘组合。●ZH



Random Solo 10 Cluster suspension lamp NEW LAMP

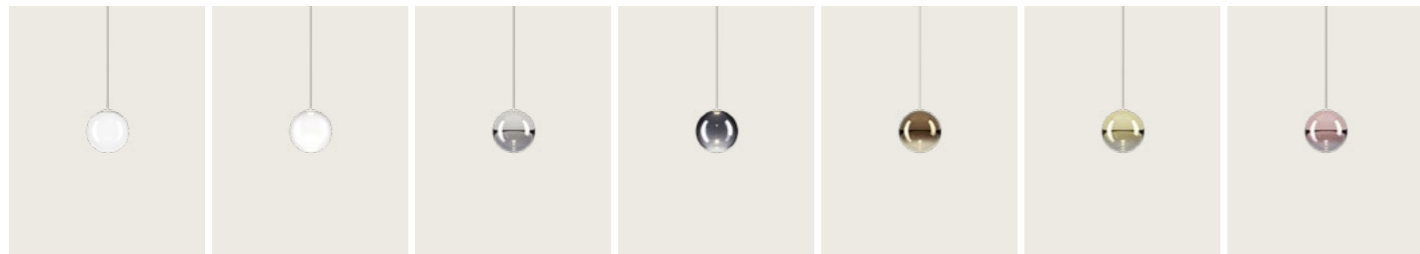

Random Solo 12 Cluster suspension lamp

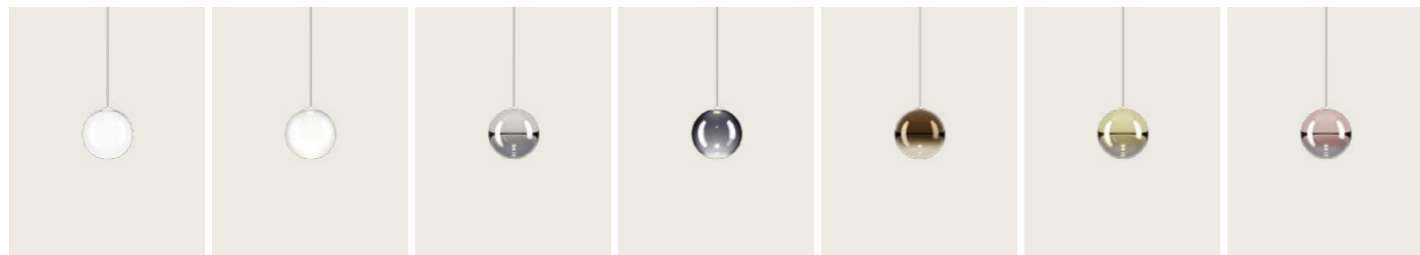

Random Solo 14 Cluster suspension lamp

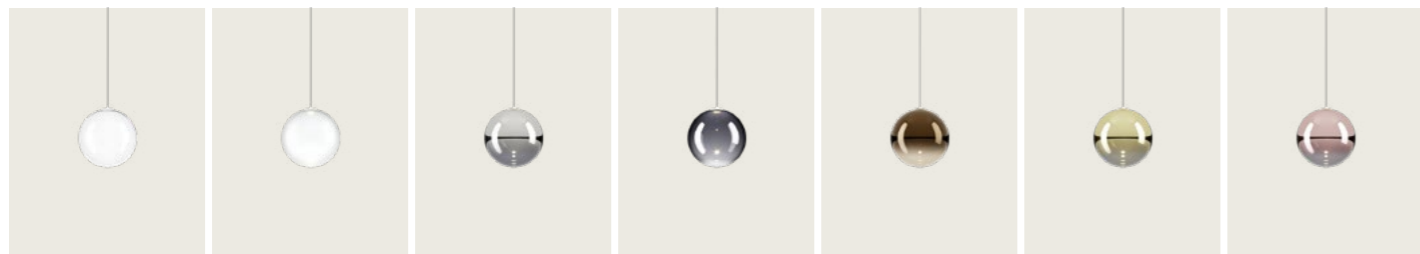

Random Solo 18 Cluster suspension lamp

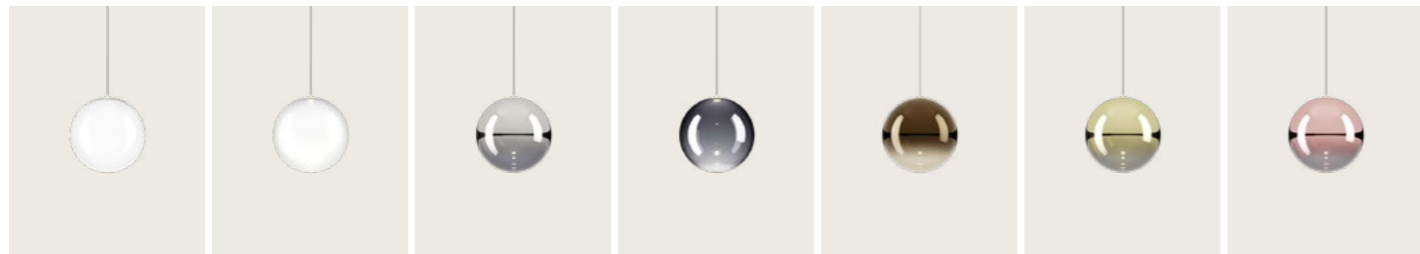

Random Solo 23 Cluster suspension lamp

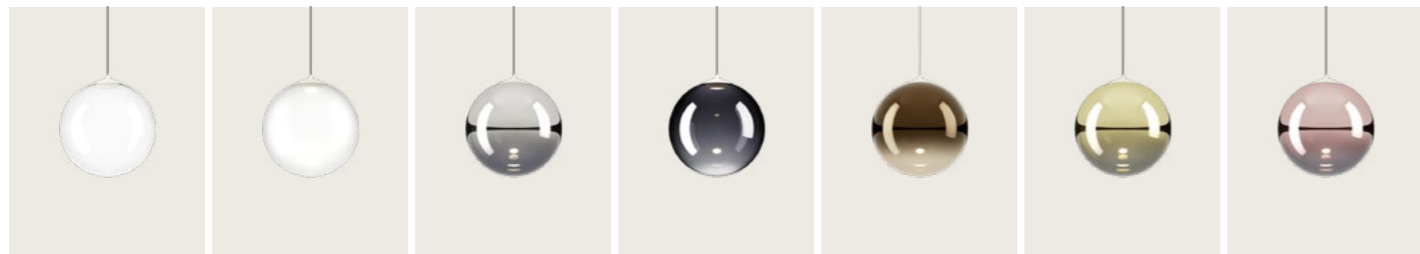

Random Solo 28 Cluster suspension lamp

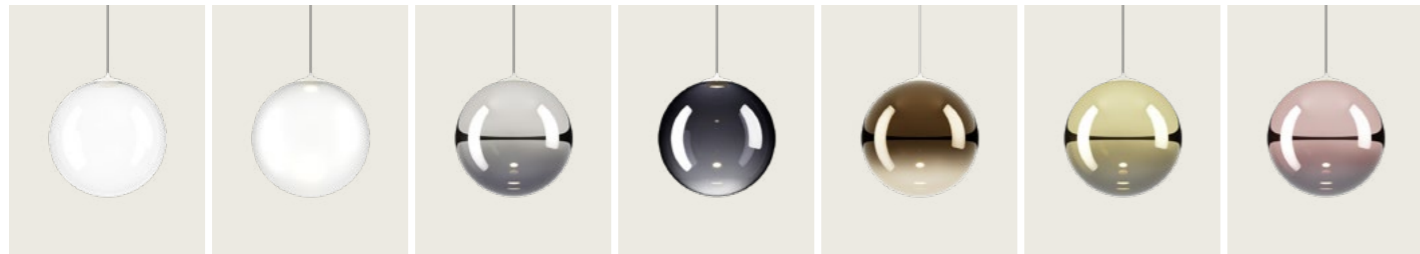

CATEGORY CLUSTER SUSPENSION LAMP

Random Solo 10 NEW

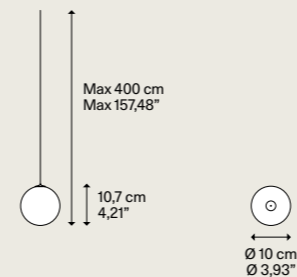

DESIGN Chia-Ying Lee, 2024

Blown glass diffuser Diffusore in vetro soffiato	Code Codice	A	Code Codice	B
Clear Trasparente	17110 0027U		17110 0030U	
Frosted White Bianco Satinato	17110 1327U		17110 1330U	
Chrome Cromo	17110 4027U		17110 4030U	
Glossy Smoke Fumo Lucido	17110 4327U		17110 4330U	
Glossy Bronze Bronzo Lucido	17110 4627U		17110 4630U	
Gold Oro	17110 5027U		17110 5030U	
Rose Gold Oro Rosa	17110 5527U		17110 5530U	

Light source
Sorgente luminosa

LED
2700 K
3 W
150 lm
350 mA
CRI 90
MacAdam 3-Step

LED included
LED incluso

Light source
Sorgente luminosa

LED
3000 K
3 W
160 lm
350 mA
CRI 90
MacAdam 3-Step

LED included
LED incluso

Net weight 0,165 kg
Peso netto 0,363 lbs

Boxes 2
Colli

IP20 Energy Saving Dim Triac

CATEGORY CLUSTER SUSPENSION LAMP

Random Solo 12

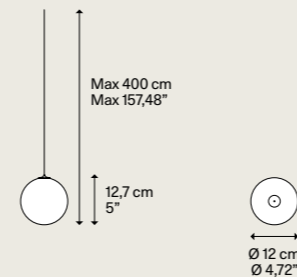

DESIGN Chia-Ying Lee, 2020

Blown glass diffuser Diffusore in vetro soffiato	Code Codice	A	Code Codice	B
Clear Trasparente	17111 0027U		17111 0030U	
Frosted White Bianco Satinato	17111 1327U		17111 1330U	
Chrome Cromo	17111 4027U		17111 4030U	
Glossy Smoke Fumo Lucido	17111 4327U		17111 4330U	
Glossy Bronze Bronzo Lucido	17111 4627U		17111 4630U	
Gold Oro	17111 5027U		17111 5030U	
Rose Gold Oro Rosa	17111 5527U		17111 5530U	

Light source
Sorgente luminosa

LED
2700 K
3 W
150 lm
350 mA
CRI 90
MacAdam 3-Step

LED included
LED incluso

Light source
Sorgente luminosa

LED
3000 K
3 W
160 lm
350 mA
CRI 90
MacAdam 3-Step

LED included
LED incluso

Net weight 0,25 kg
Peso netto 0,55 lbs

Boxes 2
Colli

IP20 Energy Saving Dim Triac

Suspension lamps must be installed on a canopy ▶ P. 434-441
Le lampade a sospensione devono essere installate su rosone ▶ P. 434-441

CATEGORY CLUSTER SUSPENSION LAMP

DESIGN Chia-Ying Lee, 2020

Random Solo 14

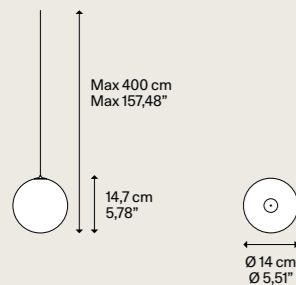

Blown glass diffuser Diffusore in vetro soffiato	Code Codice	A	Code Codice	B
Clear Trasparente	17112 0027U		17112 0030U	
Frosted White Bianco Satinato	17112 1327U		17112 1330U	
Chrome Cromo	17112 4027U		17112 4030U	
Glossy Smoke Fumo Lucido	17112 4327U		17112 4330U	
Glossy Bronze Bronzo Lucido	17112 4627U		17112 4630U	
Gold Oro	17112 5027U		17112 5030U	
Rose Gold Oro Rosa	17112 5527U		17112 5530U	

Light source Sorgente luminosa		A
LED	2700 K	
3	W	
150	lm	
350	mA	
CRI 90		
MacAdam 3-Step		
LED included LED incluso		

Light source Sorgente luminosa		B
LED	3000 K	
3	W	
160	lm	
350	mA	
CRI 90		
MacAdam 3-Step		
LED included LED incluso		

Net weight 0,32 kg
Peso netto 0,71 lbs

Boxes 2
Colli

IP20 Energy Saving Dim Triac

Random Solo 18

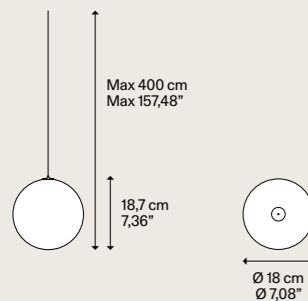

Blown glass diffuser Diffusore in vetro soffiato	Code Codice	A	Code Codice	B
Clear Trasparente	17113 0027U		17113 0030U	
Frosted White Bianco Satinato	17113 1327U		17113 1330U	
Chrome Cromo	17113 4027U		17113 4030U	
Glossy Smoke Fumo Lucido	17113 4327U		17113 4330U	
Glossy Bronze Bronzo Lucido	17113 4627U		17113 4630U	
Gold Oro	17113 5027U		17113 5030U	
Rose Gold Oro Rosa	17113 5527U		17113 5530U	

Light source Sorgente luminosa		A
LED	2700 K	
3	W	
150	lm	
350	mA	
CRI 90		
MacAdam 3-Step		
LED included LED incluso		

Light source Sorgente luminosa		B
LED	3000 K	
3	W	
160	lm	
350	mA	
CRI 90		
MacAdam 3-Step		
LED included LED incluso		

Net weight 0,80 kg
Peso netto 1,76 lbs

Boxes 2
Colli

IP20 Energy Saving Dim Triac

Suspension lamps must be installed on a canopy ▶ P. 434-441
Le lampade a sospensione devono essere installate su rosone ▶ P. 434-441

CATEGORY CLUSTER SUSPENSION LAMP

DESIGN Chia-Ying Lee, 2020

Random Solo 23

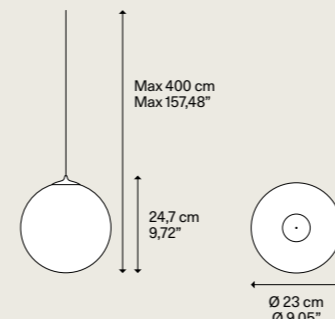

Blown glass diffuser Diffusore in vetro soffiato	Code Codice	A	Code Codice	B
Clear Trasparente	17114 0027U		17114 0030U	
Frosted White Bianco Satinato	17114 1327U		17114 1330U	
Chrome Cromo	17114 4027U		17114 4030U	
Glossy Smoke Fumo Lucido	17114 4327U		17114 4330U	
Glossy Bronze Bronzo Lucido	17114 4627U		17114 4630U	
Gold Oro	17114 5027U		17114 5030U	
Rose Gold Oro Rosa	17114 5527U		17114 5530U	

Light source Sorgente luminosa		A
LED	2700 K	
4	W	
450	lm	
350	mA	
CRI 90		
MacAdam 3-Step		
LED included LED incluso		

Light source Sorgente luminosa		B
LED	3000 K	
4	W	
480	lm	
350	mA	
CRI 90		
MacAdam 3-Step		
LED included LED incluso		

Net weight 1,10 kg
Peso netto 2,43 lbs

Boxes 2
Colli

IP20 Energy Saving Dim Triac

Random Solo 28

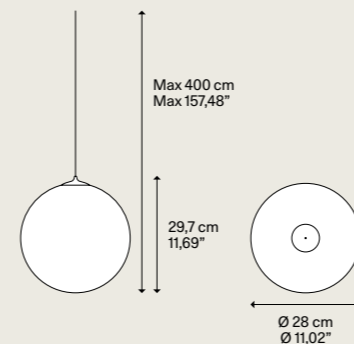

Blown glass diffuser Diffusore in vetro soffiato	Code Codice	A	Code Codice	B
Clear Trasparente	17115 0027U		17115 0030U	
Frosted White Bianco Satinato	17115 1327U		17115 1330U	
Chrome Cromo	17115 4027U		17115 4030U	
Glossy Smoke Fumo Lucido	17115 4327U		17115 4330U	
Glossy Bronze Bronzo Lucido	17115 4627U		17115 4630U	
Gold Oro	17115 5027U		17115 5030U	
Rose Gold Oro Rosa	17115 5527U		17115 5530U	

Light source Sorgente luminosa		A
LED	2700 K	
4	W	
450	lm	
350	mA	
CRI 90		
MacAdam 3-Step		
LED included LED incluso		

Light source Sorgente luminosa		B
LED	3000 K	
4	W	
480	lm	
350	mA	
CRI 90		
MacAdam 3-Step		
LED included LED incluso		

Net weight 1,60 kg
Peso netto 3,52 lbs

Boxes 2
Colli

IP20 Energy Saving Dim Triac

Suspension lamps must be installed on a canopy ▶ P. 434-441
Le lampade a sospensione devono essere installate su rosone ▶ P. 434-441

Nostalgia, design by Dima Loginoff, 2015

Nostalgia with its retro flair, *Nostalgia* elegantly tells of ancient glass blowing practices in three sinuous forms that can be combined at will. The perfection of the glass, the innovative LED technology and five elegant finishes make *Nostalgia* an extremely modern and versatile lamp that lends itself to the creation of captivating atmospheres, whether on or off. Available with a black frame and cable or chrome and transparent cable for all finishes, these combinations offer wide-ranging possibilities to personalize any space: on its own to illuminate a table or to add a sophisticated touch to a bedroom, in linear groups above a counter or peninsula, or in cluster compositions to emphasise larger spaces with refined scenic effects.

● Spec sheet p. 164

Con il suo sapore retrò, *Nostalgia* racconta con eleganza antiche storie di vetro soffiato in tre forme sinuose che possono essere combinate a piacere. La perfezione del vetro, l'innovativa tecnologia LED e le cinque raffinate finiture fanno di *Nostalgia* una lampada estremamente contemporanea e versatile che permette di creare atmosfere affascinanti sia da accesa che da spenta. Disponibile nelle versioni con montatura e cavo nero oppure cromo con cavo trasparente per tutte le finiture, tali combinazioni offrono ampie possibilità di personalizzazione di ogni spazio: da sola per illuminare un tavolo o per conferire un tocco sofisticato alla stanza da letto, in gruppi lineari sopra un bancone o una penisola, oppure in composizioni su cluster per dare risalto a spazi più ampi con raffinati effetti scenografici.



NOSTALGIA	CATEGORY LAMP		TYPE OF LIGHT	
	Cluster suspension	Sospensione cluster	Symmetrical diffused light	Luce simmetrica diffusa





Nostalgia small, medium and large, special composition of 82 lights on *recessed micro canopies*, FINISHES Clear, Glossy Smoke and Gold.







Nostalgia small on a *wall canopy*, FINISH Glossy Smoke, black cable and black structure version.



Clear



Glossy Smoke



Glossy Bronze



Gold



Rose Gold

Nostalgia small, medium and large, composition of 24 lights on a *round canopy*, FINISHES Clear and Glossy Smoke.



Avec son côté rétro, *Nostalgia* raconte avec élégance les pratiques anciennes du soufflage du verre sous trois formes sinueuses à combiner à volonté. La perfection du verre, la technologie LED innovante et les cinq finitions élégantes font de *Nostalgia* une lampe extrêmement moderne et polyvalente qui se prête à la création d'atmosphères captivantes, qu'elle soit allumée ou éteinte. Disponible dans les versions avec monture et câble noir ou chrome avec câble transparent pour toutes les finitions, ces combinaisons offrent de grandes possibilités de personnalisation de tous les espaces : seule, pour éclairer une table ou ajouter une touche sophistiquée à une chambre, en groupes linéaires au-dessus d'un comptoir ou d'un îlot, ou dans des compositions en cluster pour mettre en exergue des espaces plus grands avec des effets scéniques raffinés. ●FR

Mit ihrem Retro-Flair, erzählt *Nostalgia* auf elegante Weise von alten Glasbläsertechniken in drei gewundenen Formen, die beliebig kombiniert werden können. Die Perfektion des Glases, die innovative LED-Technologie und die fünf eleganten Ausführungen machen *Nostalgia* zu einer äußerst modernen und vielseitigen Leuchte, mit der sich sowohl im eingeschalteten als auch im ausgeschalteten Zustand faszinierende Stimmungen erzeugen lassen. Erhältlich in den Versionen mit schwarzem Gestell und Kabel oder verchromt mit transparentem Kabel für alle Ausführungen, bieten diese Kombinationen Möglichkeiten zur individuellen Gestaltung von jedem Raum: einzeln zur Beleuchtung eines Tisches oder als raffinierter Akzent in einem Schlafzimmer, in linearen Gruppen über einer Theke oder Halbinsel oder in Cluster-Kompositionen, um größere Räume mit raffinierten szenischen Effekten zu betonen. ●DE

Con su estilo retro, *Nostalgia* narra con elegancia viejas historias de vidrio soplado con tres formas sinuosas que pueden combinarse según se desee. La perfección del vidrio, la innovadora tecnología LED y sus cinco sofisticados acabados hacen de *Nostalgia* una lámpara sumamente moderna y versátil que permite crear atmósferas cautivadoras, tanto encendida como apagada. Disponible en las versiones con estructura y cable negro o bien cromada con cable transparente para todos los acabados, estas combinaciones ofrecen un gran abanico de posibilidades de personalizar cualquier espacio: por sí sola para iluminar una mesa o aportar un toque de sofisticación a un dormitorio, en grupos lineales encima de una barra o una isleta, o en grupos de lámparas colgantes para acentuar espacios más amplios con sofisticados efectos escénicos. ●ES

Nostalgia с ее ретро-стилем элегантно повествует о древнем искусстве выдувания стекла, отраженном в трех извилистых формах, которые можно сочетать по желанию. Совершенство стекла, инновационная светодиодная технология и пять элегантных вариантов отделки делают *Nostalgia* современным и универсальным светильником, создающим волшебную атмосферу как во включенном, так и в выключенном состоянии. Она доступна в версии с черной рамой и кабелем или в хромовой версии с прозрачным кабелем для всех видов отделки; эти сочетания предлагают возможности для индивидуального оформления любых помещений: она может использоваться для освещения стола или вносить изысканный штрих в спальню, применяться в линейных группах над кухонной стойкой или полуостровом, или в кластерных композициях, подчеркивающих большие пространства изысканными сценическими эффектами. ●RU

以其怀旧复古的格调, *Nostalgia*用三种可随意组合的蜿蜒形状优雅地讲述了古老玻璃吹制的实践方式。玻璃的完美、LED技术的创新和五种优雅饰面使*Nostalgia*成为一款极为现代且功能多用的灯品, 无论点亮时还是关闭时都有助于迷人氛围的营造。提供黑色框架搭配黑色线缆的版本或是镀铬框架搭配适用于所有饰面的透明线缆的版本, 这些组合扩展了将任何空间做到个性化的可能性: 它可单独照亮桌子或为卧室凭添一份精致润色。通过位于吧台或半岛上方的流线型组合或通过底盘组合彰显具有精致场景效果的更大空间。●ZH

Nostalgia small › Cluster suspension lamp



Nostalgia medium › Cluster suspension lamp



Nostalgia large › Cluster suspension lamp



CATEGORY CLUSTER SUSPENSION LAMP

DESIGN Dima Loginoff, 2015

Nostalgia small

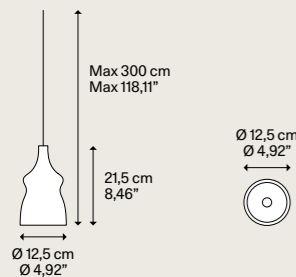

Light source
Sorgente luminosa

LED
3000 K
9 W
850 lm
120 V
CRI 92
MacAdam 3-Step
LED included
LED incluso

Net weight 0,66 kg / 1,46 lbs
Boxes Colli 2

Metal structure Montatura in metallo	Blown glass diffuser Diffusore in vetro soffiato	Code Codice
Chrome Cromo	Clear Trasparente	15422 0030U
	Glossy Smoke Fumo Lucido	15422 4330U
	Glossy Bronze Bronzo Lucido	15422 4630U
Transparent cable Cavo trasparente	Gold Oro	15422 5030U
	Rose Gold Oro Rosa	15422 5530U
	Clear Trasparente	15425 0030U
Matte Black - 9005 Nero Opaco - 9005	Glossy Smoke Fumo Lucido	15425 4330U
	Glossy Bronze Bronzo Lucido	15425 4630U
	Gold Oro	15425 5030U
Black cable Cavo nero	Rose Gold Oro Rosa	15425 5530U

IP20 Energy Saving Dim Triac

CATEGORY CLUSTER SUSPENSION LAMP

DESIGN Dima Loginoff, 2015

Nostalgia large

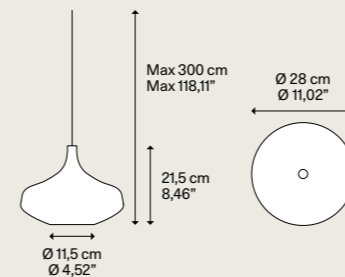

Light source
Sorgente luminosa

LED
3000 K
9 W
850 lm
120 V
CRI 92
MacAdam 3-Step
LED included
LED incluso

Net weight 1,02 kg / 2,25 lbs
Boxes Colli 2

Metal structure Montatura in metallo	Blown glass diffuser Diffusore in vetro soffiato	Code Codice
Chrome Cromo	Clear Trasparente	15424 0030U
	Glossy Smoke Fumo Lucido	15424 4330U
	Glossy Bronze Bronzo Lucido	15424 4630U
Transparent cable Cavo trasparente	Gold Oro	15424 5030U
	Rose Gold Oro Rosa	15424 5530U
	Clear Trasparente	15427 0030U
Matte Black - 9005 Nero Opaco - 9005	Glossy Smoke Fumo Lucido	15427 4330U
	Glossy Bronze Bronzo Lucido	15427 4630U
	Gold Oro	15427 5030U
Black cable Cavo nero	Rose Gold Oro Rosa	15427 5530U

IP20 Energy Saving Dim Triac

Suspension lamps must be installed on a canopy ► p. 426-433
Le lampade a sospensione devono essere installate su rosone ► p. 426-433

Nostalgia medium

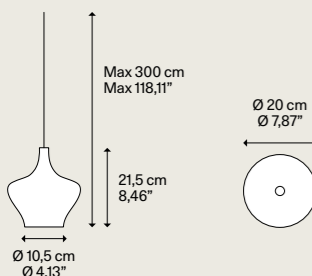

Light source
Sorgente luminosa

LED
3000 K
9 W
850 lm
120 V
CRI 92
MacAdam 3-Step
LED included
LED incluso

Net weight 0,75 kg / 1,65 lbs
Boxes Colli 2

Metal structure Montatura in metallo	Blown glass diffuser Diffusore in vetro soffiato	Code Codice
Chrome Cromo	Clear Trasparente	15423 0030U
	Glossy Smoke Fumo Lucido	15423 4330U
	Glossy Bronze Bronzo Lucido	15423 4630U
Transparent cable Cavo trasparente	Gold Oro	15423 5030U
	Rose Gold Oro Rosa	15423 5530U
	Clear Trasparente	15426 0030U
Matte Black - 9005 Nero Opaco - 9005	Glossy Smoke Fumo Lucido	15426 4330U
	Glossy Bronze Bronzo Lucido	15426 4630U
	Gold Oro	15426 5030U
Black cable Cavo nero	Rose Gold Oro Rosa	15426 5530U

IP20 Energy Saving Dim Triac

Suspension lamps must be installed on a canopy ► p. 426-433
Le lampade a sospensione devono essere installate su rosone ► p. 426-433

► LED sources with direct power supply to the AC line voltage - driver not required. Dimmable with phase cut dimmer.

► LED con alimentazione diretta a tensione di rete - non necessita di driver. Dimmerabile con varialuce a taglio di fase.

► LED sources with direct power supply to the AC line voltage - driver not required. Dimmable with phase cut dimmer.

► LED con alimentazione diretta a tensione di rete - non necessita di driver. Dimmerabile con varialuce a taglio di fase.

Jefferson, *design by* Luca Nichetto, 2019

The *Jefferson* suspension lamp designed by Luca Nichetto is reminiscent of music and iconic images in psychedelic works of art from the 1960s. The vortex motif decorating the diffuser is embellished by the timeless classicism of Bohemian crystal, which diffuses evocative atmospheres of light. Dynamic in both its sizes and multiple compositions, *Jefferson's* elegance keeps up with the excellent performance of LED interior lighting.

● Spec sheet p. 175

La lampada a sospensione *Jefferson* disegnata da Luca Nichetto rimanda alla musica e alle immagini iconiche in opere d'arte psichedeliche degli anni Sessanta. Il motivo a vortice che decora il diffusore è impreziosito dalla classicità senza tempo del cristallo di Boemia, che diffonde suggestive atmosfere di luce. Dinamica in entrambe le dimensioni e in composizioni multiple, l'eleganza di *Jefferson* non rinuncia alle eccellenti prestazioni della luce interna a LED.



JEFFERSON	CATEGORY LAMP		TYPE OF LIGHT	
	Cluster suspension	Sospensione cluster	Diffused light	Luce diffusa





Jefferson mini and small, special composition of 68 lights, FINISH Clear + Gold.



169 Cluster suspension lamp

Jefferson



1



2

1 Jefferson mini and small, composition of 5 lights on a round canopy, FINISH Clear + Gold.
 2 Jefferson mini, FINISH Clear + Black Chrome.



Jefferson mini, composition of 30 lights on a *round canopy*,
FINISH Clear + Black Chrome.



La suspension *Jefferson* dessinée par Luca Nichetto fait référence à la musique et aux images emblématiques des œuvres d'art psychédélics des années Soixante. Le motif vortex qui orne le diffuseur est rehaussé par le classicisme intemporel du cristal de Bohême, qui diffuse des atmosphères de lumière suggestives. Dynamique dans les deux tailles et dans de multiples compositions, l'élégance de *Jefferson* ne renonce jamais aux excellentes performances de l'éclairage intérieur LED. ●FR

Die von Luca Nichetto entworfene Hängeleuchte „Jefferson“ erinnert an die Musik und die ikonischen Darstellungen in psychedelischen Kunstwerken der sechziger Jahre. Die Wirbel-Optik des Diffusors wird aufgewertet durch den klassisch-zeitlosen Stil des böhmischen Kristalls, das suggestive Lichtstimmungen erzeugt. Dynamisch in beiden Größen und in vielfältigen Kompositionen, verzichtet die Eleganz von *Jefferson* nicht auf die hervorragende Leistung der LED-Innenbeleuchtung. ●DE

La lámpara de suspensión *Jefferson* diseñada por Luca Nichetto evoca la música y las imágenes icónicas en obras de arte psicodélicas de los años 60. El motivo en espiral que decora el difusor lo embellece el clasicismo atemporal del cristal de Bohemia que difunde atmósferas sugestivas de luz. Dinámica en ambos tamaños y en composiciones múltiples, la elegancia de *Jefferson* no renuncia a las excelentes prestaciones de la luz interna de LED. ●ES

Подвесной светильник *Jefferson*, дизайн Лука Никетто, вызывает в памяти музыку и культовые изображения на психоделических произведениях шестидесятих годов. Ценность вихревому украшению диффузора придает вечная классика богемского хрусталя, благодаря которому создается необыкновенная световая атмосфера. Элегантная и динамичная в обоих размерах и множественных комбинациях модель *Jefferson* не отказывается от превосходных характеристик внутреннего светодиодного освещения. ●RU

Luca Nichetto受上世纪六十年代迷幻视觉艺术的音乐和图案的启发设计了吊灯*Jefferson*。灯罩上装饰的漩涡图案因波西米亚水晶的永恒古典主义更显精美珍贵，将迷人的光线散发开来。*Jefferson*吊灯具有两种尺寸和多种组成的动态变化，精美雅致的同时更良好利用了内置LED灯的出色性能。●ZH

Jefferson mini › Cluster suspension lamp



Jefferson small › Cluster suspension lamp



CATEGORY CLUSTER SUSPENSION LAMP

Jefferson mini

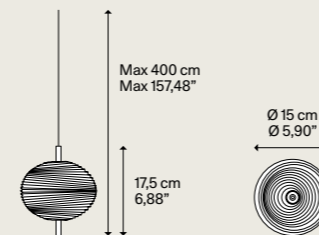

Net weight	1,40 kg	Boxes	1
Peso netto	3,09 lbs	Colli	1

DESIGN Luca Nichetto, 2019

Metal structure
Montatura in metallo

- Black Chrome
Cromo Nero
- Gold
Oro

Light source
Sorgente luminosa

LED
2700 K
5 W
450 lm
350 mA
CRI 90
MacAdam 3-Step

LED included
LED incluso

Bohemian crystal diffuser
Diffusore in cristallo di Boemia

- Clear
Trasparente
- Clear
Trasparente

Code
Codice

16821 4227U
16821 5027U

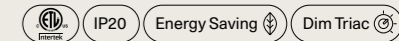

Jefferson small

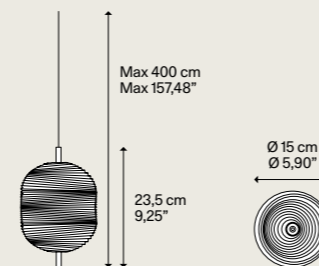

Net weight	2,10 kg	Boxes	1
Peso netto	4,63 lbs	Colli	1

Metal structure
Montatura in metallo

- Black Chrome
Cromo Nero
- Gold
Oro

Light source
Sorgente luminosa

LED
2700 K
5 W
450 lm
350 mA
CRI 90
MacAdam 3-Step

LED included
LED incluso

Bohemian crystal diffuser
Diffusore in cristallo di Boemia

- Clear
Trasparente
- Clear
Trasparente

Code
Codice

16822 4227U
16822 5027U

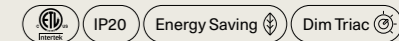

Suspension lamps must be installed on a canopy ▶ p. 434–441
Le lampade a sospensione devono essere installate su rosone ▶ p. 434–441

IVY, design by Vittorio Massimo, 2022

IVY is a minimal, geometric lighting piece composed of a die-cast zinc alloy ring hanging on a black cable, which gives power to a made to measure LED module. The product sheds an even, rounded light beam through its thin and curved methacrylate diffuser. Designed with single and double cables, IVY responds to the need for flexibility, an increasingly contemporary theme in architectural practice and restoration, allowing the luminaire to be released from its ceiling derivation. Imagining the repetition and clustering of several lamps suggested the name IVY, while the ring reminds of a precious pendant on a necklace.

● Spec sheet p. 190

IVY è una lampada dalle linee minimaliste e geometriche costituita da un anello in lega di zinco pressofuso sospeso ad un cavo nero che aziona un modulo a LED realizzato su misura. Il prodotto emette un fascio di luce uniforme e omogeneo attraverso il sottile diffusore curvo in metacrilato. Dotata di cavi singoli e doppi, IVY risponde alla crescente esigenza di flessibilità nell'attuale contesto delle attività architettoniche e di ristrutturazione, consentendo di riposizionare la lampada rispetto alla fonte di alimentazione a soffitto. L'idea della ripetizione e del raggruppamento di più lampade ha ispirato il nome IVY, dall'inglese "edera", mentre l'anello richiama il prezioso ciondolo di una collana.



IVY	CATEGORY LAMP		TYPE OF LIGHT	
	Cluster suspension Suspension	Sospensione cluster Sospensione	Symmetrical diffused light	Luce simmetrica diffusa

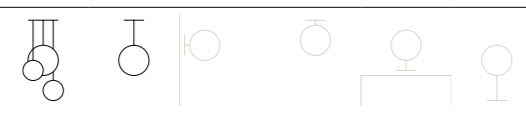





1



2

1 IVY V, FINISH Matte Black.
 2 IVY V, composition of 6 lights on a *central canopy*, FINISH Matte Black.



IVY I, composition of 36 lights on a *round canopy*, FINISHES Matte Black and Matte Champagne.



1



2

Cluster suspension lamp, Suspension lamp
 1 IVY V, FINISH Matte Champagne.
 2 IVY V, FINISH Terra.

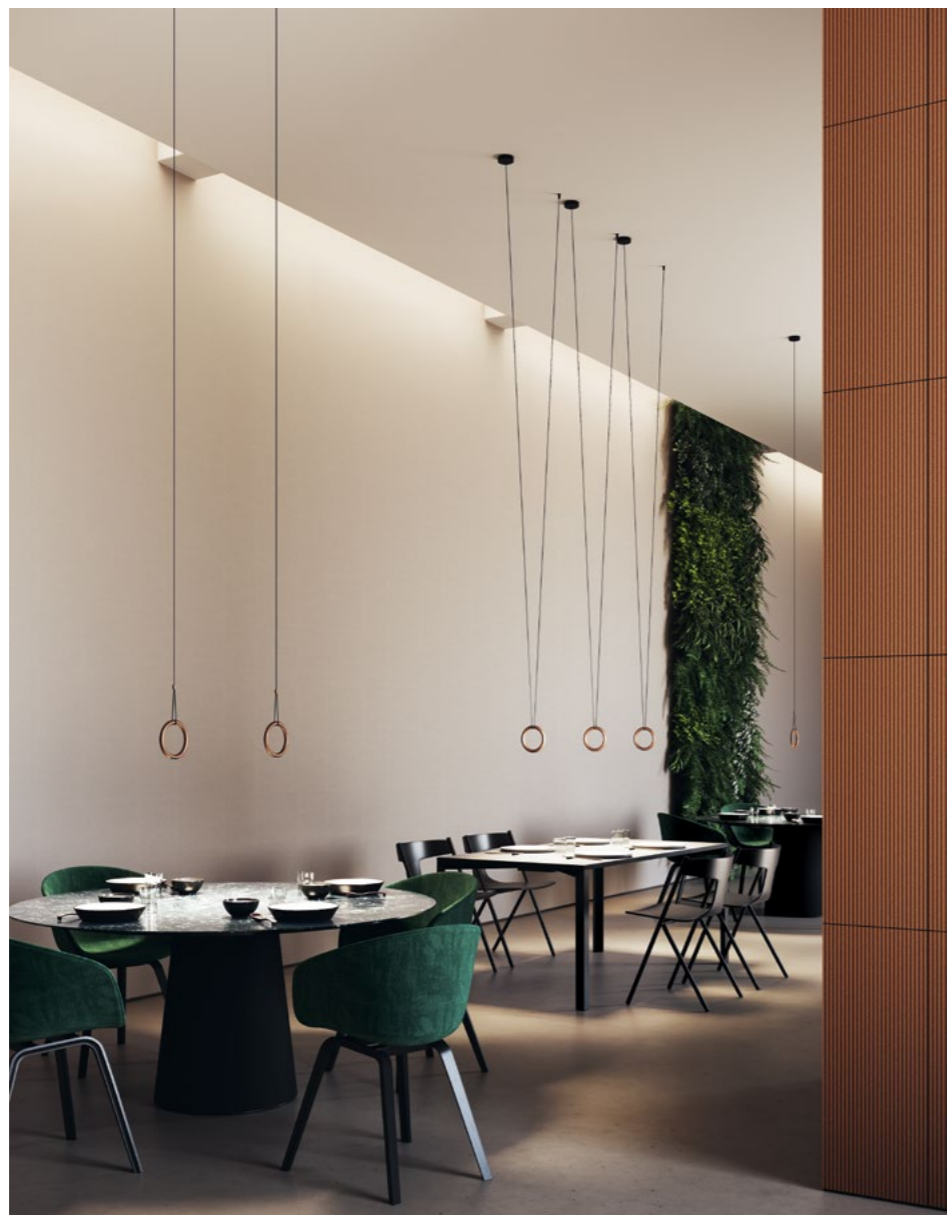

IVY I and V, *single mini canopies*, FINISH Terra.



Cluster suspension lamp,
Suspension lamp

IVY I and V, FINISHES Matte Black, Matte Champagne and Terra.



IVY I, composition of 14 lights on a *rectangular canopy*, FINISHES Matte Black, Matte Champagne and Terra.

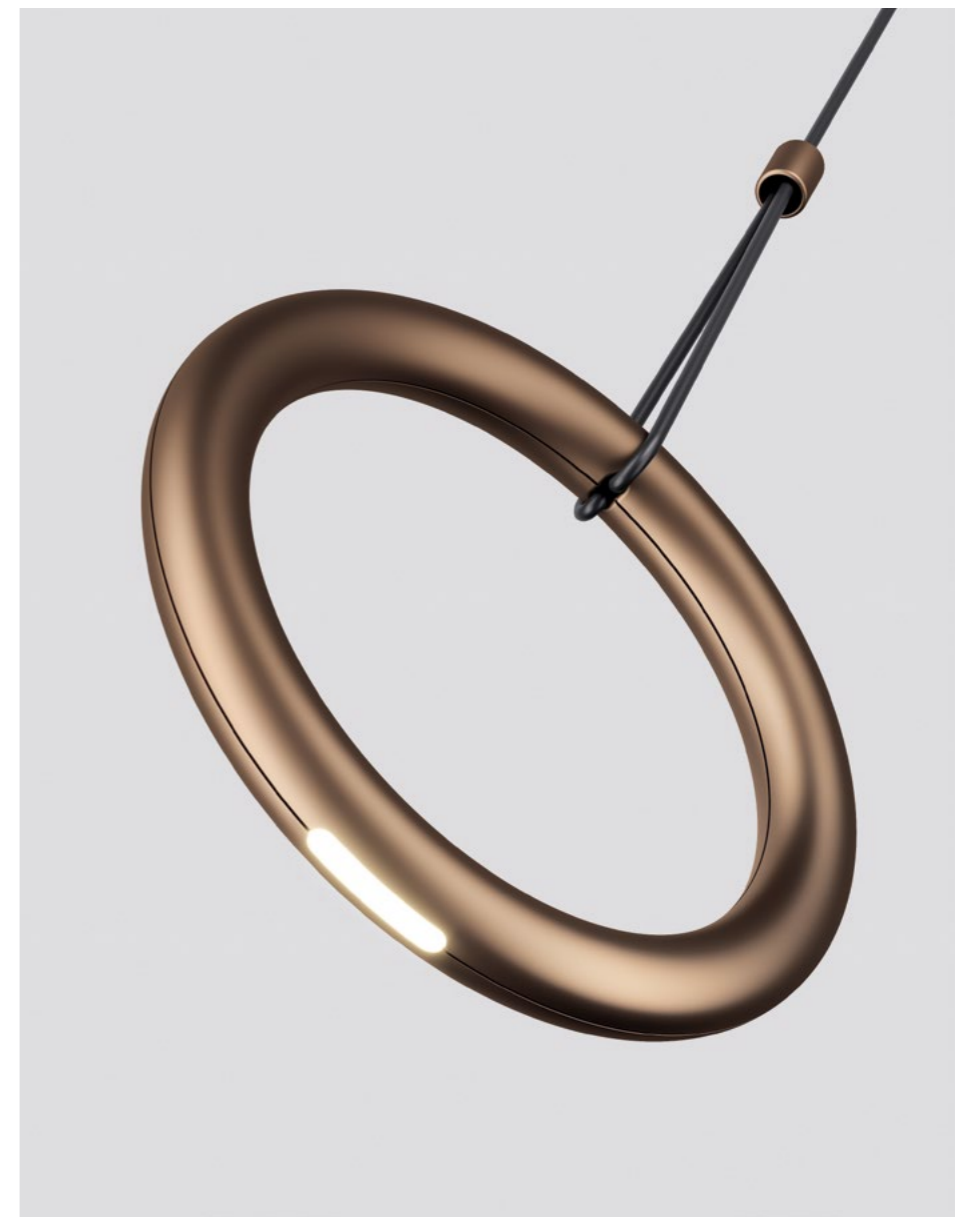

IVY est un élément d'éclairage minimaliste et géométrique fait d'un anneau en alliage de zinc moulé sous pression, suspendu à un câble noir qui alimente un module LED sur mesure. Le produit diffuse un faisceau lumineux uniforme et arrondi grâce à son diffuseur en méthacrylate fin et incurvé. Conçu avec des câbles simples et doubles, *IVY* répond au besoin de flexibilité, un thème de plus en plus contemporain dans la pratique architecturale et la restauration, permettant au luminaire d'être libéré de sa dérivation de plafond. Le nom *IVY*, anglais pour « lierre », s'inspire du regroupement de plusieurs lampes en cluster, tandis que l'anneau rappelle le précieux pendentif d'un collier. ●FR

IVY ist ein minimalistisches, geometrisches Beleuchtungsobjekt, bestehend aus einem Ring aus druckgegossener Zinklegierung, aufgehängt an einem schwarzen Kabel, das ein maßgefertigtes LED-Modul mit Strom versorgt. Das Produkt wirft einen gleichmäßigen, runden Lichtstrahl durch seinen dünnen und gebogenen Methacrylat-Diffusor. Entworfen mit einzelnen und doppelten Kabeln ist *IVY* die Antwort auf das Bedürfnis nach Flexibilität, ein zunehmend aktuelles Thema in der architektonischen Praxis und Restoration, das es der Leuchte ermöglicht, sich von ihrer Deckenableitung zu lösen. Die Vorstellung von der Wiederholung und Cluster mit mehreren Leuchten inspirierten zu dem Namen *IVY*, englisch für „Efeu“, während der Ring an einen kostbaren Anhänger einer Halskette erinnert. ●DE

IVY es un elemento de iluminación minimalista y geométrico compuesto de un aro de aleación de cinc fundido que cuelga de un cable negro, el cual alimenta a un módulo LED hecho a medida. La lámpara proyecta un haz de luz redondeado y homogéneo a través de su fino y curvado difusor de metacrilato. Diseñada con cables individuales y dobles, *IVY* responde a la necesidad de flexibilidad, una temática cada vez más de actualidad en la arquitectura y la restauración, que permite liberar el punto de luz de su derivación en el techo. El nombre *IVY*, «hiedra» en inglés, sugiere la repetición y la agrupación de varias lámparas, mientras que su aro recuerda al colgante de un collar. ●ES

IVY – это минималистичный геометрический осветительный элемент, состоящий из литого под давлением кольца, выполненного из цинкового сплава, подвешенного на черном кабеле, подающем питание к индивидуально изготовленному светодиодному модулю. Лампа излучает ровный круглый световой луч, проходящий через тонкий и изогнутый диффузор из метакрилата. Спроектированная с использованием одинарных и двойных кабелей, лампа *IVY* отвечает потребности в универсальности, все более актуальной в современной архитектуре и реконструкциях, позволяя освободить светильник от связи с потолком. Образ повторяющихся и объединенных в кластер ламп подсказал название *IVY*, что в переводе с английского означает "плющ", само кольцо напоминает драгоценный кулон на колье. ●RU

IVY 是一款极简几何照明件,由一只悬挂于一根黑色线缆上的压铸锌合金圆环组成,线缆可为定制型LED模块供电。该产品通过其细薄而弯曲的甲基丙烯酸酯灯罩散发均匀的圆形光束。采用单线缆和双线缆设计,*IVY*回应了对灵活性的需求,这是建筑实践与装修中一个日趋现代的主题,可将灯具重新定位到一个与位于天花板的电源处有所不同的地方。*IVY*之名建立在对更多灯件的重复和组吊的想象中,而圆环则令人忆起项链上的精美吊坠。●ZH

IVY I » Cluster suspension lamp

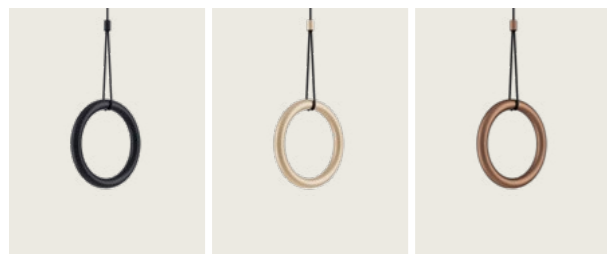

IVY V » Central cluster suspension lamp, Suspension lamp

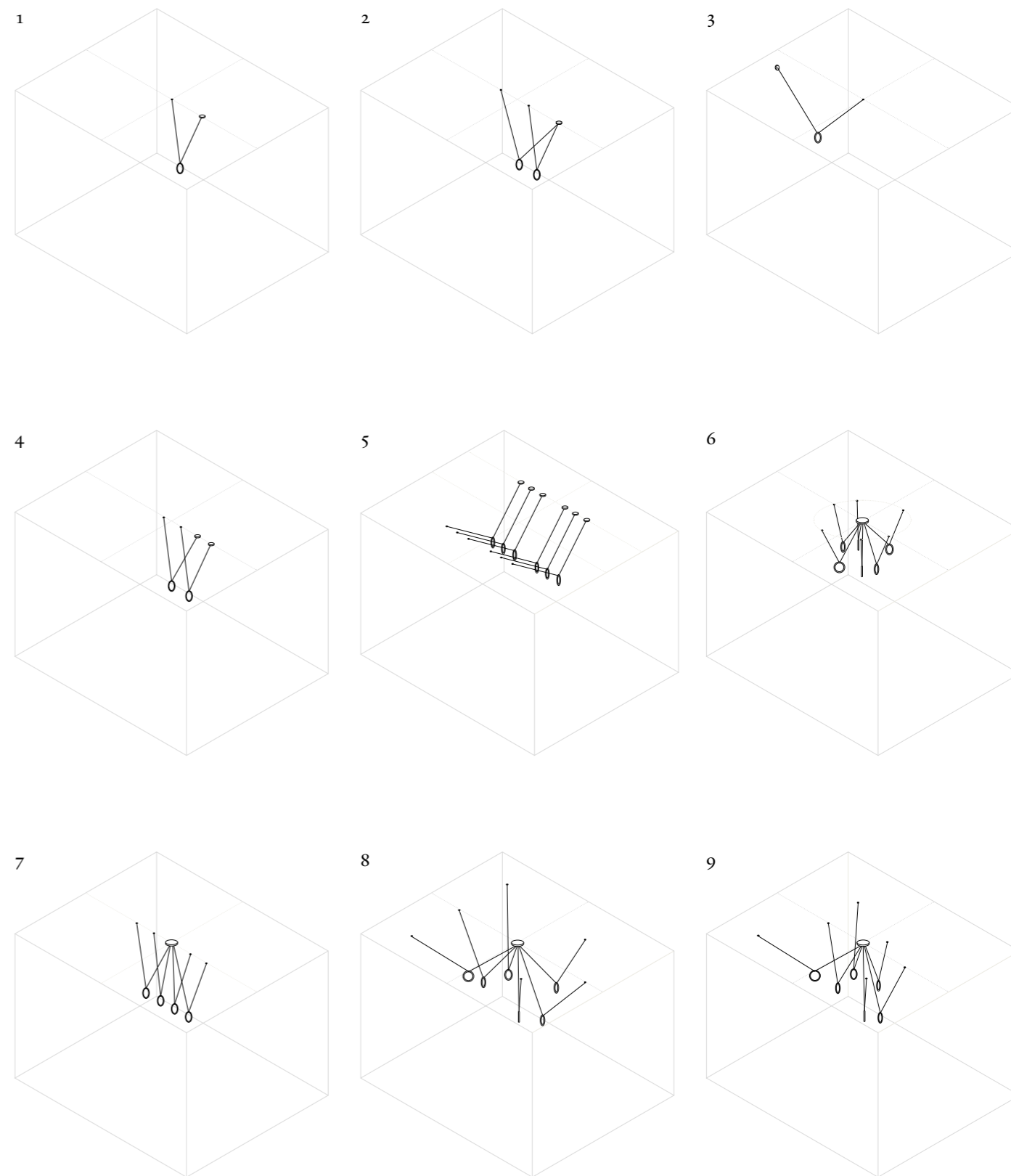
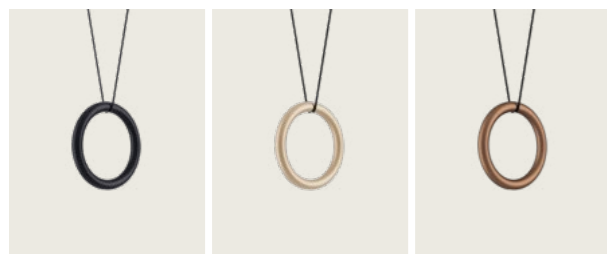

CATEGORY CLUSTER SUSPENSION LAMP

DESIGN Vittorio Massimo, 2022

IVY I

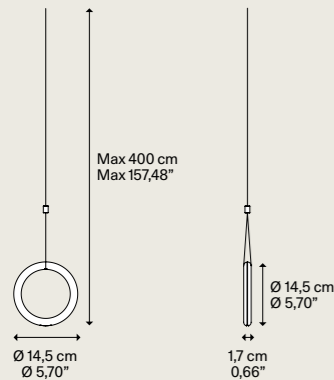

Metal structure Montatura in metallo	Cable Cavo	Code Codice
● Matte Black - 9005 Nero Opaco - 9005	⊖ Black Nero	17810 2035U
● Extra Matte Champagne Champagne Extra Opaco	⊖ Black Nero	17810 4535U
● Terra Terra	⊖ Black Nero	17810 6735U

Light source
Sorgente luminosa

LED
3000 K
4 W
480 lm
350 mA
CRI 92
MacAdam 3-Step

LED included
LED incluso

Net weight 0,50 kg
Peso netto 1,10 lbs

Boxes 1
Colli 1

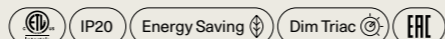

Suspension lamps must be installed on a canopy ▶ P. 434-441
Le lampade a sospensione devono essere installate su rosone ▶ P. 434-441

CATEGORY CENTRAL CLUSTER SUSPENSION LAMP

DESIGN Vittorio Massimo, 2022

IVY V

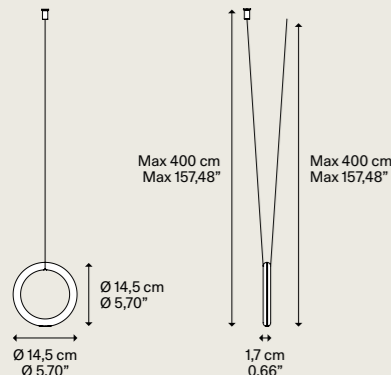

Metal structure Montatura in metallo	Cable Cavo	Code Codice
● Matte Black - 9005 Nero Opaco - 9005	⊖ Black Nero	17820 2035U
● Extra Matte Champagne Champagne Extra Opaco	⊖ Black Nero	17820 4535U
● Terra Terra	⊖ Black Nero	17820 6735U

Light source
Sorgente luminosa

LED
3000 K
4 W
480 lm
350 mA
CRI 92
MacAdam 3-Step

LED included
LED incluso

Net weight 0,58 kg
Peso netto 1,27 lbs

Boxes 1
Colli 1

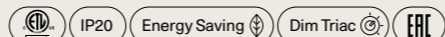

IVY V suspension lamps must only be installed on the single and central canopies below
Le lampade a sospensione IVY V devono essere installate solamente sui rosoni singoli e centrali di seguito

CATEGORY SINGLE CANOPY

Single

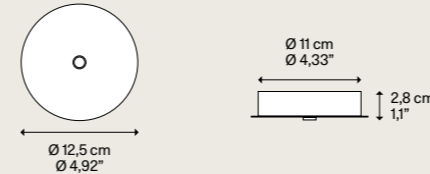

Net weight 0,40 kg
Peso netto 0,88 lbs

Boxes 1
Colli 1

Mounts directly to a 4" Standard J-Box



Description
Descrizione

Single ceiling bracket
standard size

Rosone per lampada
singola versione standard

Metal structure
Struttura in metallo

● Matte Black - 9005
Nero Opaco - 9005

System
Sistema

Single

Code
Codice

R03L01 2000MU

CATEGORY RECESSED CANOPY

Low Voltage Recessed Micro

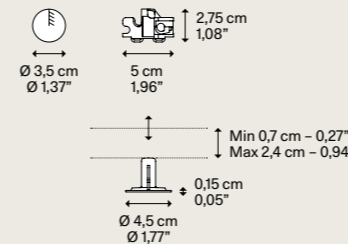

Net weight 0,015 kg
Peso netto 0,033 lbs

Boxes 1
Colli 1

Description
Descrizione

Recessed bracket for
single lamp max capacity
3,5 kg - 77,16 lbs
Driver not included

Rosone da incasso per
lampada singola portata
max 3,5 kg - 77,16 lbs
Driver non incluso

Methacrylate structure
Struttura in metacrilato

● Matte Black
Nero Opaco

System
Sistema

Recessed

Code
Codice

R01L01 2000U



CATEGORY CENTRAL CANOPY

6 Lights Central

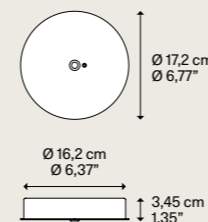

Net weight 0,58 kg
Peso netto 1,27 lbs

Boxes 1
Colli 1

Description
Descrizione

Central canopy
max 6 suspension
Driver included

Rosone centrale
max 6 sospensioni
Driver incluso

Metal structure
Struttura in metallo

● Matte Black - 9005
Nero Opaco - 9005

System
Sistema

Cluster Central

Code
Codice

R07L06 2000MU



CATEGORY CENTRAL CANOPY

12 Lights Central

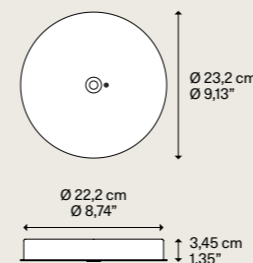

Net weight 1,00 kg
Peso netto 2,20 lbs

Boxes 1
Colli 1

Description
Descrizione

Central canopy
max 12 suspension
Driver included

Rosone centrale
max 12 sospensioni
Driver incluso

Metal structure
Struttura in metallo

● Matte Black - 9005
Nero Opaco - 9005

System
Sistema

Cluster Central

Code
Codice

R07L12 2000MU



JIM, design by Patrick Norguet, 2021

Immediate function, uncomplicated style, durable materials, modular at will. Inspired by the abat-jours of the ateliers of the early 1900s, *JIM* is a system of suspension lamps with distinctive shapes and a versatile composition that suits any interiors and living environment. *JIM*'s versatility is further enhanced by the colour range: the two finishes for the shades can be combined with the two different suspension hook hues as desired.

● Spec sheet p. 202

Immediatezza di funzione, semplicità delle linee, materiali durevoli, componibilità a piacere. Ispirato ai paralumi degli atelier di artisti dell'inizio del 1900, *JIM* è un sistema di lampade a sospensione dalle forme distintive e dalla composizione versatile che si adatta a qualsiasi interno e ambiente abitativo. La versatilità di *JIM* è ulteriormente valorizzata dalla gamma cromatica: le due finiture disponibili per i paralumi possono essere combinate a piacere con le due diverse tonalità del gancio a cui è sospesa la lampada.



JIM	CATEGORY LAMP		TYPE OF LIGHT	
	Cluster suspension Suspension	Sospensione cluster Sospensione	Symmetrical diffused light	Luce simmetrica diffusa

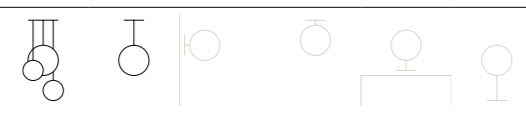









JIM bell, cylinder and cone, composition of 3 lights on a *round canopy*, FINISH Matte Black.

Immédiateté de fonction, simplicité des lignes, matériaux durables, infinie modularité. S'inspirant des abat-jours des ateliers d'artistes du début du XXe siècle, JIM est un système de suspensions arborant des formes distinctives et une composition polyvalente qui s'adapte à tous les styles d'habitation. La gamme chromatique souligne encore plus la polyvalence de JIM : les deux finitions disponibles pour les diffuseurs peuvent s'assortir, au choix, aux deux différentes tonalités du crochet de soutien. ●FR

Unmittelbarkeit der Funktion, Einfachheit der Linien, haltbare Materialien, Modularität nach Belieben. Inspiriert an den Lampenschirmen der Künstlerateliers der frühen 1900er Jahre, ist JIM ein Hängeleuchtsystem mit unverwechselbaren Formen und vielseitiger Gestaltungsmöglichkeit, das sich an jedes Interieur und jede Wohnumgebung anpasst. Die Vielseitigkeit von JIM wird durch die Farbpalette noch verstärkt: Die zwei erhältlichen Ausführungen der Lampenschirme können beliebig mit den zwei verschiedenen Farbtönen des Hakens, an dem die Leuchte aufgehängt wird, kombiniert werden. ●DE

Inmediatez de función, líneas sencillas, materiales duraderos y libertad de modularidad. Inspirado en las pantallas de los ateliers de artistas de principios del siglo XX, JIM es un sistema de lámparas de suspensión con formas características y una composición versátil que se adapta a cualquier interior y ambiente. La versatilidad de JIM la valoriza aún más la gama cromática: los dos acabados disponibles para las pantallas se pueden combinar libremente con los dos tonos del gancho en el que está suspendida la lámpara. ●ES

Немедленно доступная функциональность, несложный стиль, прочные материалы, модульность по желанию. Лампа воспроизводит стиль абажуров творческих ателье начала 1900-х. JIM представляет собой систему подвесных ламп особой формы, с универсальной композицией, подходящей для любых внутренних интерьеров и дизайна жилья. Универсальность JIM дополнительно расширена благодаря диапазону цветов: две отделки абажуров сочетаются по желанию с двумя разными тональностями подвесных крюков. ●RU

功能即时、风格简洁、材料耐用、组合随意。灵感源于二十世纪初期艺术家工坊中的灯罩，JIM是一款形状独特且组合多样的悬吊灯系统，适用于任何室内装饰与家居环境。JIM的通用性以其色彩范围之广越发增值：灯罩的两种饰面可按喜好与悬灯钩的两种不同色调相搭配。●ZH

JIM bell ↘ Cluster suspension lamp

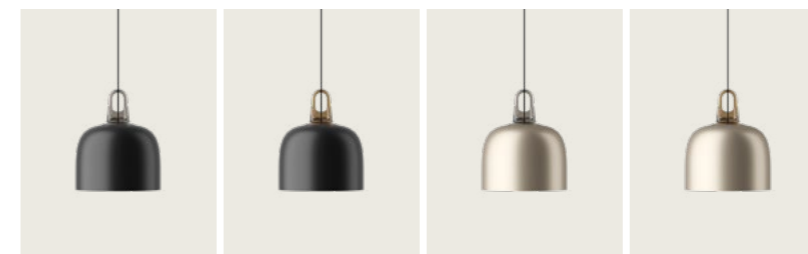

JIM cone ↘ Cluster suspension lamp



JIM cylinder ↘ Cluster suspension lamp

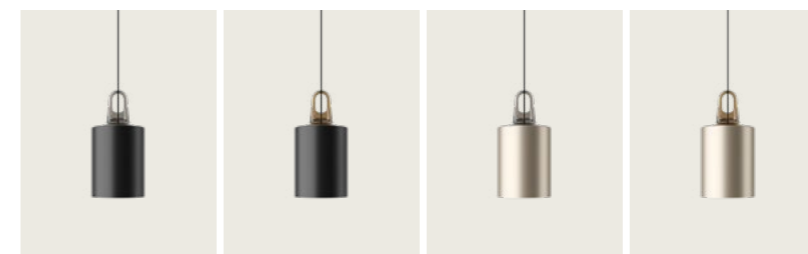

JIM dome ↘ Suspension lamp

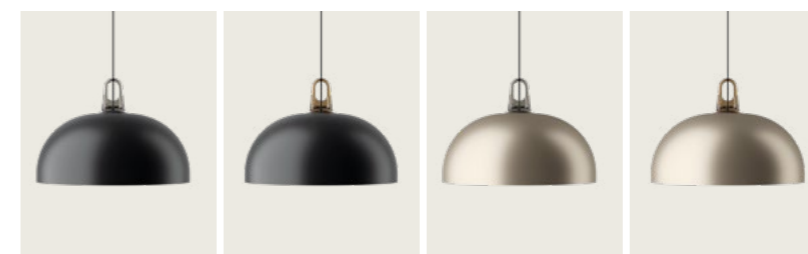

Grey hook
Gancio Grigio



Honey hook
Gancio Miele

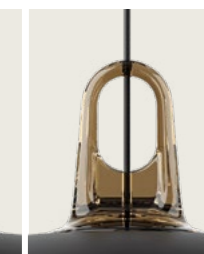

CATEGORY CLUSTER SUSPENSION LAMP

DESIGN Patrick Norguet, 2021

JIM bell

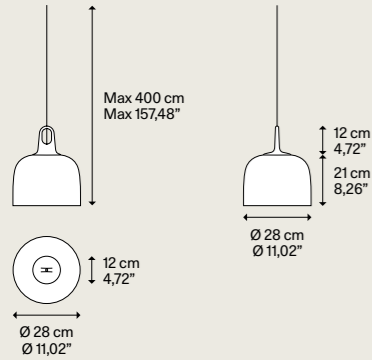

Net weight 1,90 kg / 4,19 lbs
Boxes Colli 2

Outside metal diffuser Diffusore esterno in metallo	Inside metal diffuser Diffusore interno in metallo	Hook methacrylate Gancio in metacrilato	Code Codice
● Matte Black - 9005 Nero Opaco - 9005	● Matte White - 9010 Bianco Opaco - 9010	● Grey Grigio	16921 2800U
		● Honey Miele	16921 6600U
		● Grey Grigio	16921 2700U
● Matte Champagne Champagne Opaco	● Matte White - 9010 Bianco Opaco - 9010	● Honey Miele	16921 6500U

Light source
Sorgente luminosa

Medium Base
E26 LED
1 x max 25 W
120 V

Bulb not included
Lampadina non inclusa

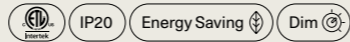

JIM cone

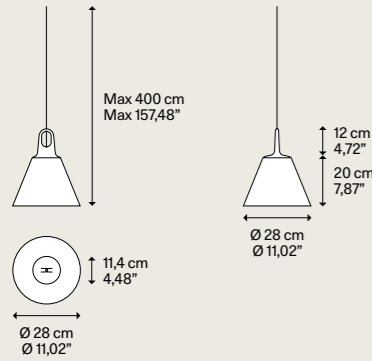

Net weight 1,00 kg / 2,20 lbs
Boxes Colli 2

Outside metal diffuser Diffusore esterno in metallo	Inside metal diffuser Diffusore interno in metallo	Hook methacrylate Gancio in metacrilato	Code Codice
● Matte Black - 9005 Nero Opaco - 9005	● Matte White - 9010 Bianco Opaco - 9010	● Grey Grigio	16922 2800U
		● Honey Miele	16922 6600U
		● Grey Grigio	16922 2700U
● Matte Champagne Champagne Opaco	● Matte White - 9010 Bianco Opaco - 9010	● Honey Miele	16922 6500U

Light source
Sorgente luminosa

Medium Base
E26 LED
1 x max 25 W
120 V

Bulb not included
Lampadina non inclusa

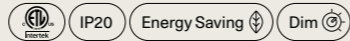

JIM cylinder

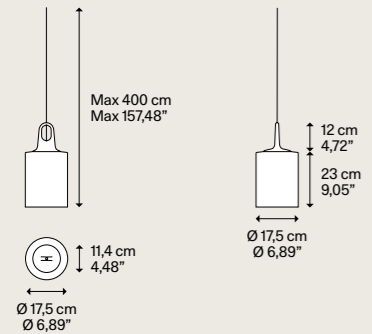

Net weight 1,40 kg / 3,09 lbs
Boxes Colli 2

Outside metal diffuser Diffusore esterno in metallo	Inside metal diffuser Diffusore interno in metallo	Hook methacrylate Gancio in metacrilato	Code Codice
● Matte Black - 9005 Nero Opaco - 9005	● Matte White - 9010 Bianco Opaco - 9010	● Grey Grigio	16923 2800U
		● Honey Miele	16923 6600U
		● Grey Grigio	16923 2700U
● Matte Champagne Champagne Opaco	● Matte White - 9010 Bianco Opaco - 9010	● Honey Miele	16923 6500U

Light source
Sorgente luminosa

Medium Base
E26 LED
1 x max 25 W
120 V

Bulb not included
Lampadina non inclusa

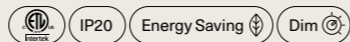

Suspension lamps must be installed on a canopy ▶ P. 426-433
Le lampade a sospensione devono essere installate su rosone ▶ P. 426-433

CATEGORY SUSPENSION LAMP

DESIGN Patrick Norguet, 2021

JIM dome

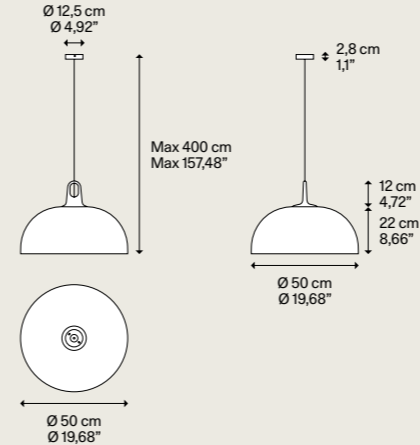

Net weight 2,20 kg / 4,85 lbs
Boxes Colli 2
Mounts directly to a 4" Standard J-Box

Outside metal diffuser Diffusore esterno in metallo	Inside metal diffuser Diffusore interno in metallo	Hook methacrylate Gancio in metacrilato	Code Codice
● Matte Black - 9005 Nero Opaco - 9005	● Matte White - 9010 Bianco Opaco - 9010	● Grey Grigio	16924 2800U
		● Honey Miele	16924 6600U
		● Grey Grigio	16924 2700U
● Matte Champagne Champagne Opaco	● Matte White - 9010 Bianco Opaco - 9010	● Honey Miele	16924 6500U

Light source
Sorgente luminosa

Medium Base
E26 LED
1 x max 25 W
120 V

Bulb not included
Lampadina non inclusa

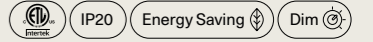

A-Tube Nano, *design by* Studio Italia Design, 2016

A-Tube Nano is a suspension light which interprets light in its simplest form by creating a thin luminous line in the living spaces. At the lower end of the lightweight aluminium structure, a transparent methacrylate diffuser houses an LED module whose light creates a soft, welcoming atmosphere. The three sizes and six statement finishes, allow to create clusters of evocative lighting.

A-Tube Nano è una lampada a sospensione che interpreta la luce nella sua forma più essenziale disegnando una sottile linea luminosa nello spazio abitativo. All'estremità inferiore della leggera struttura in alluminio, un diffusore in metacrilato trasparente ospita un modulo LED la cui luce crea un'atmosfera morbida e avvolgente. Le tre dimensioni e le sei versatili finiture, permettono di realizzare suggestive composizioni su cluster.

● Spec sheet p. 220

A-TUBE NANO	CATEGORY LAMP		TYPE OF LIGHT	
	Cluster suspension	Sospensione cluster	Symmetrical diffused light	Luce simmetrica diffusa





A- Tube Nano large, special composition of 655 lights on recessed micro canopies, FINISH Matte Champagne.

A-Tube Nano large, *recessed micro canopy*,
FINISH Terra, black cable version.





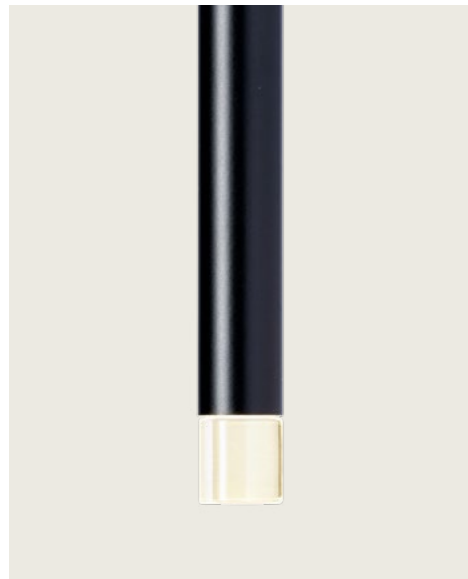

Matte Black

Chrome

Matte Champagne



Gold

Rose Gold

Terra







A-*Tube Nano* small, medium and large, composition of 14 lights on a *rectangular canopy*, FINISHES Matte Black and Chrome, black cable version.



A-*Tube Nano* medium, composition of 5 lights on a *round canopy*, FINISH Matte Black.

*A-*Tube Nano** est une suspension qui interprète la lumière dans sa forme la plus essentielle en dessinant une fine ligne lumineuse dans l'espace de vie. À l'extrémité inférieure de la structure en aluminium léger, un diffuseur en méthacrylate transparent abrite un module LED dont la lumière crée une atmosphère douce et enveloppante. Les trois dimensions et les six finitions polyvalentes permettent de créer des compositions évocatrices en cluster. ●FR

*A-*Tube Nano** ist eine Hängeleuchte, die das Licht in seiner einfachsten Form interpretiert und für einen schmalen Lichtstreifen im Wohnraum sorgt. Am unteren Ende der leichten Armatur aus Aluminium enthält ein Diffusor aus Methacrylat ein LED-Modul, dessen Licht eine angenehme und umhüllende Atmosphäre entstehen lässt. Die drei Größen und sechs vielseitigen Ausführungen ermöglichen die Umsetzung zauberhafter Kombinationen in Clustern. ●DE

*A-*Tube Nano** es una lámpara de suspensión que interpreta la luz en su forma más esencial dibujando una delgada línea luminosa en el espacio habitable. En el extremo inferior de la estructura ligera de aluminio, un difusor de metacrilato transparente aloja un módulo LED cuya luz crea una atmósfera suave y envolvente. Los tres tamaños y los seis versátiles acabados permiten realizar composiciones sugestivas en grupos de lámparas de suspensión. ●ES

*A-*Tube Nano** – это подвесной светильник, который повторяет основную форму света, рисуя в жилом пространстве тонкую линию луча. В нижней части легкой алюминиевой конструкции в прозрачном диффузоре из металакрилата установлен светодиодный модуль, свет которого создает мягкую и обволакивающую атмосферу. Возможность выбора из трех размеров и шести универсальных отделок позволяет создавать потрясающие композиции на кластерах. ●RU

*A-*Tube Nano**是一款吊灯，以简约的形式诠释灯光，在居住空间中勾勒出纤细的光线。在轻盈的铝材结构下端，安装了透明的甲基丙烯酸酯灯罩，内置LED模块，灯光营造柔和温馨的气氛。三种尺寸和六种不同颜色，可打造迷人的组合吊。●ZH

A-*Tube Nano* small ▸ Cluster suspension lamp

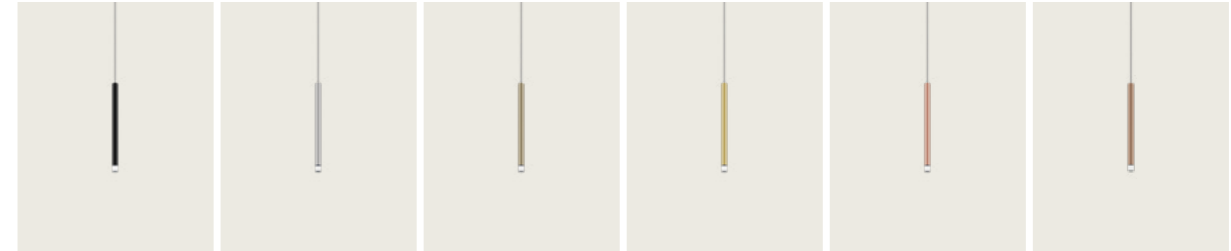

A-*Tube Nano* medium ▸ Cluster suspension lamp



A-*Tube Nano* large ▸ Cluster suspension lamp

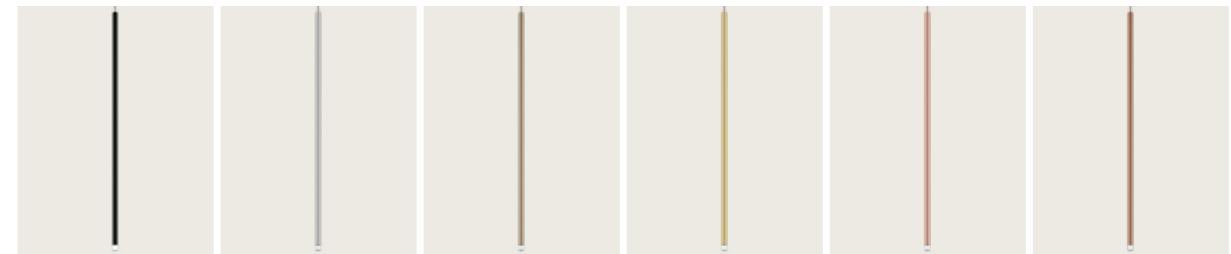

Transparent cable

Black cable



CATEGORY CLUSTER SUSPENSION LAMP

DESIGN Studio Italia Design, 2016

A-Tube Nano small

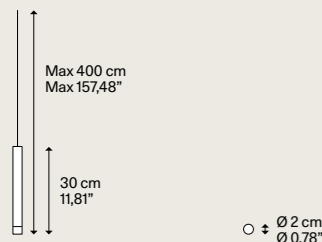

Light source
Sorgente luminosa

LED
2700 K
4 W
450 lm
350 mA
CRI 90
MacAdam 3-Step

LED included
LED incluso

Net weight 0,22 kg
Peso netto 0,48 lbs
Boxes 2
Colli 2

Metal structure Montatura in metallo	Methacrylate diffuser Diffusore in metacrilato	Code Codice
● Matte Black - 9005 Nero Opaco - 9005		15822 2020U
● Chrome Cromo		15822 4020U
● Matte Champagne Champagne Opaco		15822 4520U
● Gold Oro	○ Clear Trasparente	15822 5020U
● Rose Gold Oro Rosa		15822 5520U
● Terra Terra	○ Transparent cable Cavo trasparente	15822 6720U
● Matte Black - 9005 Nero Opaco - 9005		15826 2020U
● Chrome Cromo		15826 4020U
● Matte Champagne Champagne Opaco		15826 4520U
● Gold Oro	○ Clear Trasparente	15826 5020U
● Rose Gold Oro Rosa		15826 5520U
● Terra Terra	○ Black cable Cavo nero	15826 6720U

CE IP20 Energy Saving Dim Triac

CATEGORY CLUSTER SUSPENSION LAMP

DESIGN Studio Italia Design, 2016

A-Tube Nano large

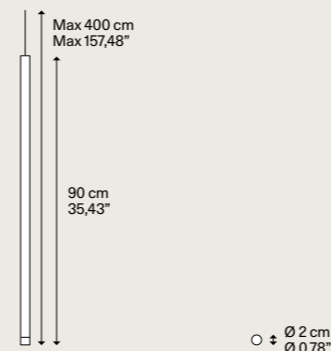

Light source
Sorgente luminosa

LED
2700 K
4 W
450 lm
350 mA
CRI 90
MacAdam 3-Step

LED included
LED incluso

Net weight 0,40 kg
Peso netto 0,88 lbs
Boxes 2
Colli 2

Metal structure Montatura in metallo	Methacrylate diffuser Diffusore in metacrilato	Code Codice
● Matte Black - 9005 Nero Opaco - 9005		15824 2020U
● Chrome Cromo		15824 4020U
● Matte Champagne Champagne Opaco		15824 4520U
● Gold Oro	○ Clear Trasparente	15824 5020U
● Rose Gold Oro Rosa		15824 5520U
● Terra Terra	○ Transparent cable Cavo trasparente	15824 6720U
● Matte Black - 9005 Nero Opaco - 9005		15828 2020U
● Chrome Cromo		15828 4020U
● Matte Champagne Champagne Opaco		15828 4520U
● Gold Oro	○ Clear Trasparente	15828 5020U
● Rose Gold Oro Rosa		15828 5520U
● Terra Terra	○ Black cable Cavo nero	15828 6720U

CE IP20 Energy Saving Dim Triac

Suspension lamps must be installed on a canopy ► p. 434-441
Le lampade a sospensione devono essere installate su rosone ► p. 434-441

A-Tube Nano medium

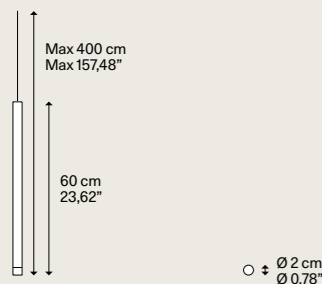

Light source
Sorgente luminosa

LED
2700 K
4 W
450 lm
350 mA
CRI 90
MacAdam 3-Step

LED included
LED incluso

Net weight 0,30 kg
Peso netto 0,66 lbs
Boxes 2
Colli 2

Metal structure Montatura in metallo	Methacrylate diffuser Diffusore in metacrilato	Code Codice
● Matte Black - 9005 Nero Opaco - 9005		15823 2020U
● Chrome Cromo		15823 4020U
● Matte Champagne Champagne Opaco		15823 4520U
● Gold Oro	○ Clear Trasparente	15823 5020U
● Rose Gold Oro Rosa		15823 5520U
● Terra Terra	○ Transparent cable Cavo trasparente	15823 6720U
● Matte Black - 9005 Nero Opaco - 9005		15827 2020U
● Chrome Cromo		15827 4020U
● Matte Champagne Champagne Opaco		15827 4520U
● Gold Oro	○ Clear Trasparente	15827 5020U
● Rose Gold Oro Rosa		15827 5520U
● Terra Terra	○ Black cable Cavo nero	15827 6720U

CE IP20 Energy Saving Dim Triac

Suspension lamps must be installed on a canopy ► p. 434-441
Le lampade a sospensione devono essere installate su rosone ► p. 434-441

A-Tube Nano Duo, *design by* Studio Italia Design, 2017

Precious pins suspended from a thin cable, like magic lights floating in the space. *A-Tube Nano Duo* is an offshoot of *A-Tube Nano* with an LED light source on both ends of its thin metal body. A lightweight and linear lamp available in six finishes, including the new Terra, which allows to create evocative and playful cluster compositions.

● Spec sheet p. 231

Preziose barrette sospese ad un cavo sottile, come magiche luci che galleggiano nello spazio. *A-Tube Nano Duo* è una variante di *A-Tube Nano* con sorgente luminosa a LED su entrambe le estremità del sottile corpo metallico. Una lampada leggera e lineare disponibile in sei finiture, inclusa la nuova tonalità Terra, con le quali si possono realizzare suggestive e giocose composizioni su cluster.

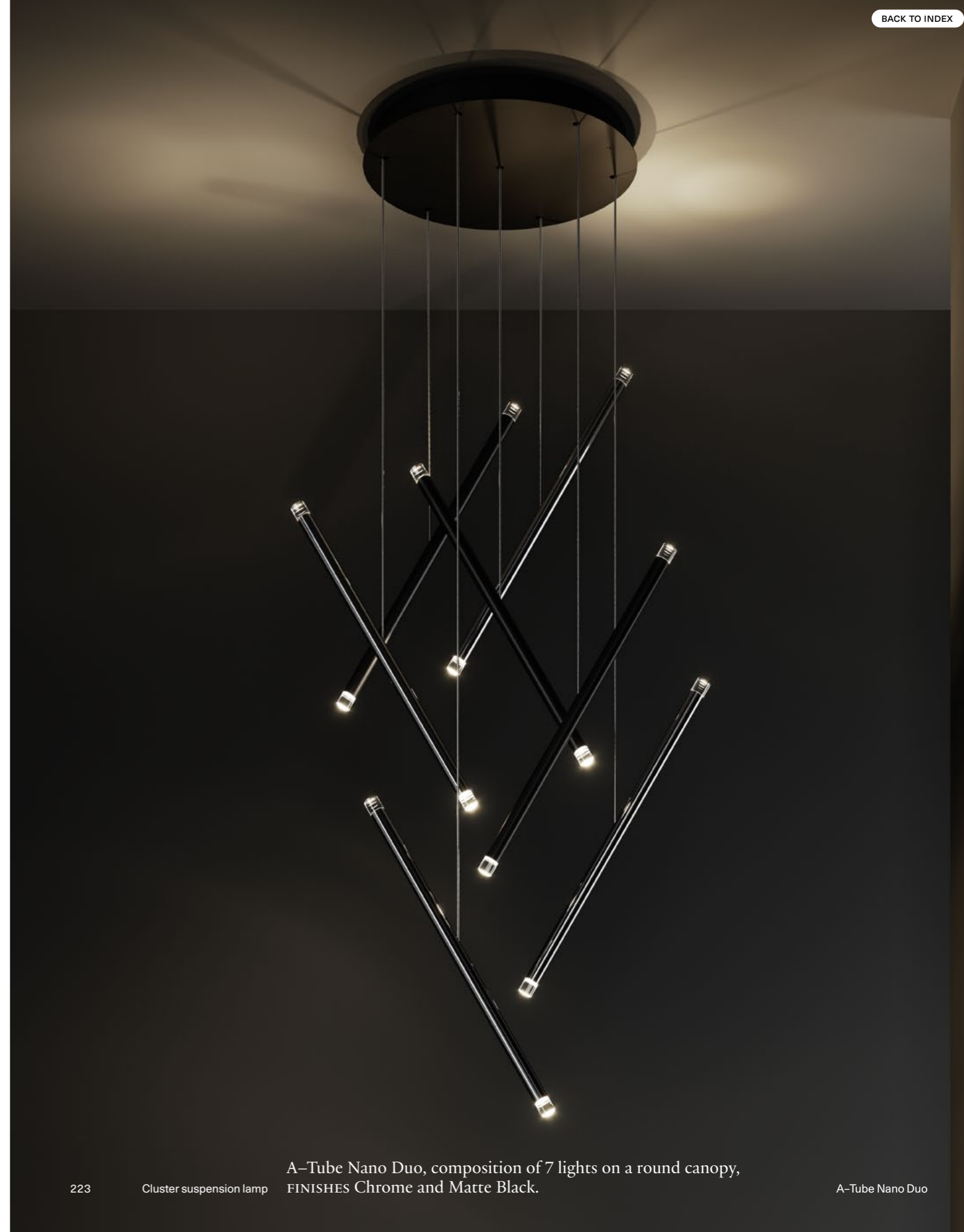

A-TUBE NANO DUO	CATEGORY LAMP		TYPE OF LIGHT	
	Cluster suspension	Sospensione cluster	Symmetrical diffused light	Luce simmetrica diffusa





A-Tube Nano Duo, compositions of 24 lights on a *round canopy*, FINISH Gold.



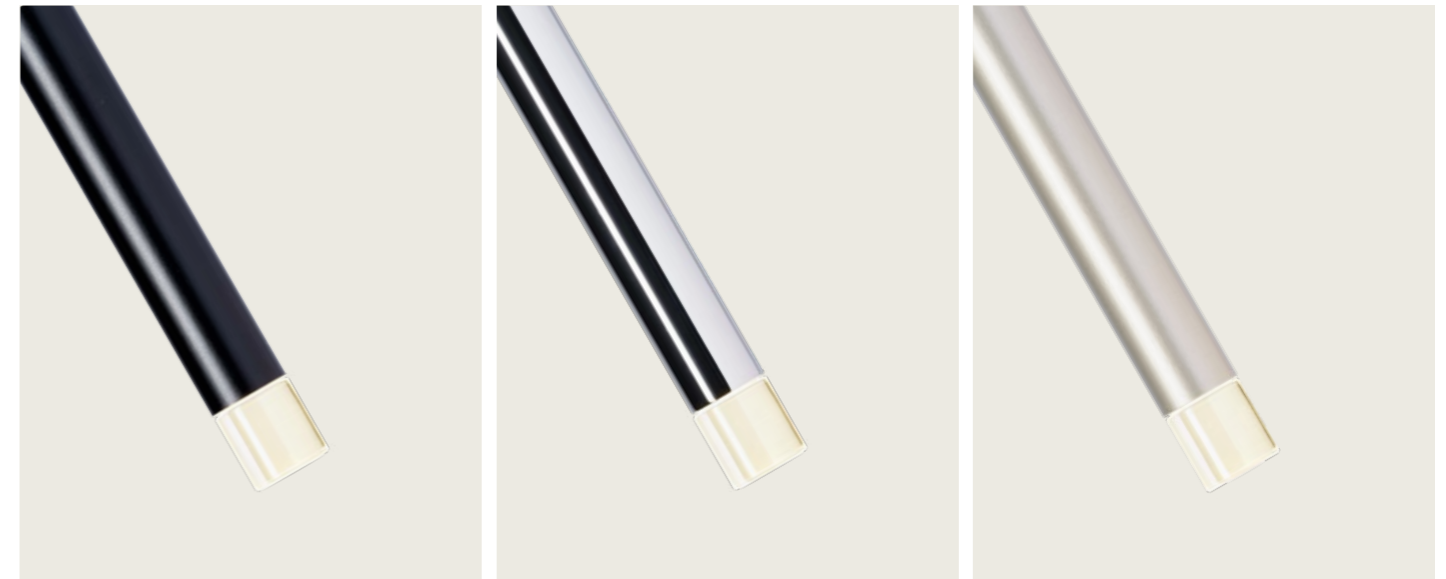

Matte Black

Chrome

Matte Champagne



Gold

Rose Gold

Terra

De précieuses barres suspendues à un câble fin, comme des lumières magiques flottant dans l'espace. *A-Tube Nano Duo* est une variante de *A-Tube Nano* avec une source de lumière LED aux deux extrémités du fin corps métallique. Une lampe légère et linéaire disponible en six finitions, comprenant la nouvelle tonalité Terra, qui permettent de créer des compositions en cluster, évocatrices et ludiques. ●FR

Wertvolle Balken, die an einem schmalen Kabel hängen, wie magisches Licht, das im Raum schwebt. *A-Tube Nano Duo* ist eine Variante von *A-Tube Nano* mit LED-Lichtquelle an beiden Enden des dünnen Metallkorpusses. Eine leichte und lineare Leuchte, in sechs Ausführungen verfügbar, darunter auch der neue Farbton Terra, mit denen wunderbare und verspielte Cluster-Kombinationen geschaffen werden können. ●DE

Preciosas barras suspendidas de un fino cable, como luces mágicas que flotan en el espacio. *A-Tube Nano Duo* es una variante de *A-Tube Nano* con fuente luminosa de LED en ambos extremos del sutil cuerpo de metal. Una lámpara ligera y lineal disponible en seis acabados, incluido el nuevo tono Tierra, con los que se pueden crear sugestivas y divertidas composiciones en grupos de lámparas de suspensión. ●ES

Изящные трубки, подвешенные на тонком кабеле, – словно волшебные огни, парящие в пространстве. Светильник *A-Tube Nano Duo* является вариантом *A-Tube Nano* с источником света LED на обоих концах тонкого металлического корпуса. Легкая прямолинейная лампа доступна в шести вариантах отделки, включая новую тональность Terra, с использованием которых можно создавать очаровательные и живые кластерные композиции. ●RU

通过细细的电缆线将贵重的条形悬挂起来，就像漂浮在太空中的魔幻灯一样。*A-Tube Nano Duo*是*A-Tube Nano*的变型，在纤薄金属主体的两端均带有LED光源。这是一种轻巧的线性灯，有包含全新大地色调在内的六种颜色，可以在组合吊上创建富有启发性和趣味性的构造。●ZH

CATEGORY CLUSTER SUSPENSION LAMP

A-Tube Nano Duo

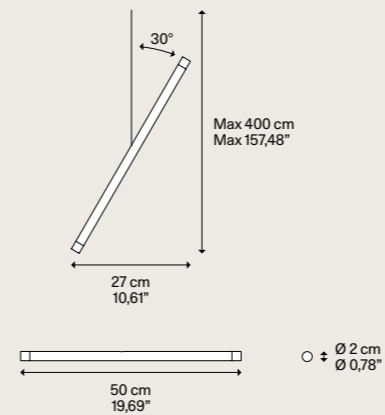
Light source
Sorgente luminosa

LED
2700 K
4 W
300 lm
350 mA
CRI 90
MacAdam 3-Step

LED included
LED incluso

Net weight 0,21 kg
Peso netto 0,46 lbs
Boxes 1
Colli 1

DESIGN Studio Italia Design, 2017

Metal structure
Montatura in metallo

- Matte Black - 9005
Nero Opaco - 9005
- Chrome
Cromo
- Matte Champagne
Champagne Opaco
- Gold
Oro
- Rose Gold
Oro Rosa
- Terra ^{NEW}
Terra

Methacrylate diffuser
Diffusore in metacrilato

○ Clear
Trasparente

○ Transparent cable
Cavo trasparente

Code
Codice

15825 2020U

15825 4020U

15825 4520U

15825 5020U

15825 5520U

15825 6720U

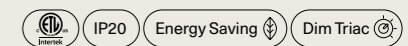

Suspension lamps must be installed on a canopy ► P. 434-441
Le lampade a sospensione devono essere installate su rosone ► P. 434-441

A-Tube Nano Duo » Cluster suspension lamp



A-*Tube*, design by Studio Italia Design, 2013

A simple form that delivers the light to wherever it's needed, enhancing the space. Tubular and slim, *A-*Tube** is a versatile lamp available in four different sizes and three finishes. It can be fixed directly to the ceiling, suspended singularly, or used in cluster compositions to create impactful lighting effects.

● Spec sheet p. 240

Una forma semplice, che porta la luce dove si desidera valorizzando l'ambiente. Tubolare e sottile, *A-*Tube** è una lampada versatile, disponibile in diverse dimensioni e in tre finiture. Può essere fissata direttamente al soffitto, sospesa singolarmente, oppure utilizzata in composizioni cluster d'effetto.



A-TUBE	CATEGORY LAMP		TYPE OF LIGHT	
	Cluster suspension Ceiling	Sospensione cluster Soffitto	Symmetrical diffused light	Luce simmetrica diffusa

A-*Tube* medium, small and large, composition of 3 lights on a *round canopy*, FINISH Coppery Bronze.





Une forme simple, qui éclaire où vous le souhaitez tout en valorisant l'environnement. Tubulaire et fine, *A-Tube* est une lampe polyvalente, disponible en différentes dimensions et trois finitions. Elle peut être fixée directement au plafond, suspendue individuellement ou utilisée en compositions cluster. ●FR

Eine einfache Form, die das Licht in jenen Bereich des Raums bringt, der betont werden soll. Röhrenförmig und dünn, ist *A-Tube* eine vielseitige Lampe, die in verschiedenen Größen und drei Ausführungen verfügbar ist. Sie kann direkt an der Decke befestigt werden, einzeln hängend, oder zu wirkungsvollen Clustern kombiniert. ●DE

Una forma simple, que lleva la luz donde se desea valorizando el ambiente. Tubular y sutil, la *A-Tube* es una lámpara versátil, disponible en diferentes tamaños y tres acabados. Puede fijarse directamente al techo, suspenderse individualmente o utilizarse en composiciones de grupos de lámparas colgantes de efecto. ●ES

Простая незамысловатая форма, несущая свет туда, где это необходимо, и украшающая интерьер. Светильник *A-Tube* в форме тонкой изящной трубки является необыкновенно универсальным и доступен с разными размерами и с тремя типами отделки. Его можно крепить непосредственно к потолку, повесить отдельно или использовать в качестве эффектных кластерных композиций. ●RU

外形简洁，可将光线照射到想要的地方。*A-Tube*呈管状且细长，是一种多功能灯，有不同尺寸和三种颜色可供选择。它可以直接吸顶安装，可以单独悬吊安装，也可以组合吊式安装。●ZH



A-Tube mini ↘ Ceiling lamp

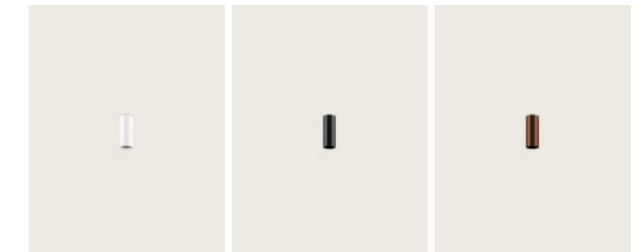

A-Tube small ↘ Cluster suspension lamp



A-Tube small ↘ Ceiling lamp

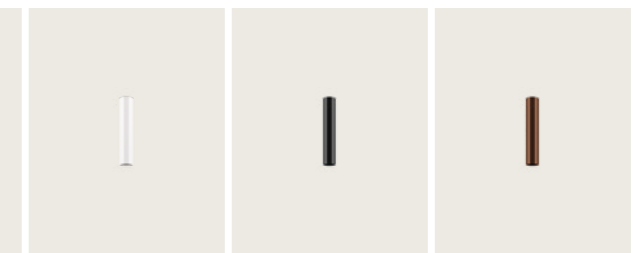

A-Tube medium ↘ Cluster suspension lamp

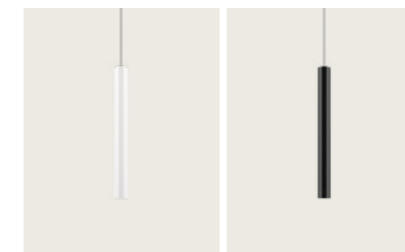

A-Tube medium ↘ Ceiling lamp

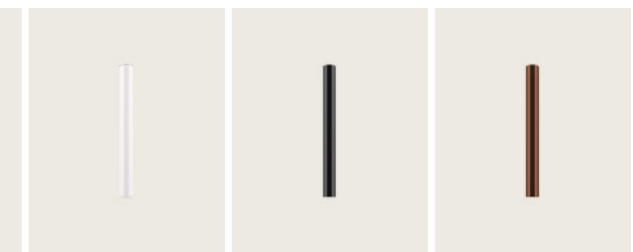

A-Tube large ↘ Cluster suspension lamp



A-Tube large ↘ Ceiling lamp

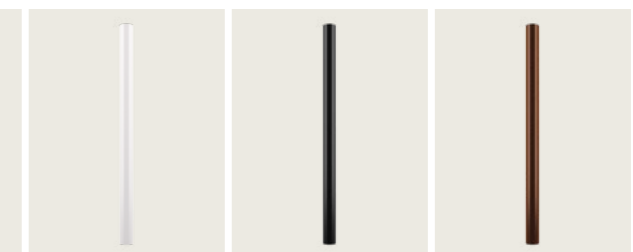

CATEGORY CLUSTER SUSPENSION LAMP

DESIGN Studio Italia Design, 2013

A-Tube small

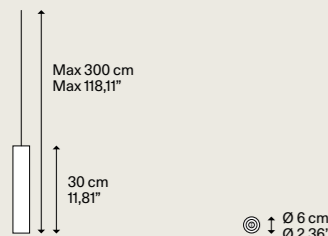

Net weight 1,12 kg / 2,47 lbs
Boxes Colli 1

Light source Sorgente luminosa

Medium Base E26 Par 16 LED
1 x max 8 W
120 V
W/L max 6 cm / W/L max 2,4"
Ø max 5 cm / Ø max 1,96"

Bulb not included
Lampadina non inclusa

Metal structure Montatura in metallo

Matte White - 9010 Bianco Opaco - 9010	09622 1000U
Matte Black - 9005 Nero Opaco - 9005	09622 2000U
Coppery Bronze Bronzo Ramato	09622 3500U

IP20 Energy Saving Dim

CATEGORY CEILING LAMP

DESIGN Studio Italia Design, 2013

A-Tube mini

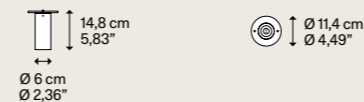

Net weight 0,20 kg / 0,44 lbs
Boxes Colli 1
Mounts directly to a 4" Standard J-Box - Plate Adaptor included *

Light source Sorgente luminosa

Medium Base E26 Par 16 LED
1 x max 8 W
120 V
W/L max 6 cm / W/L max 2,4"
Ø max 5 cm / Ø max 1,96"

Bulb not included
Lampadina non inclusa

Metal structure Montatura in metallo

Matte White - 9010 Bianco Opaco - 9010	09631 1000U
Matte Black - 9005 Nero Opaco - 9005	09631 2000U
Coppery Bronze Bronzo Ramato	09631 3500U

IP20 Energy Saving Dim

A-Tube medium

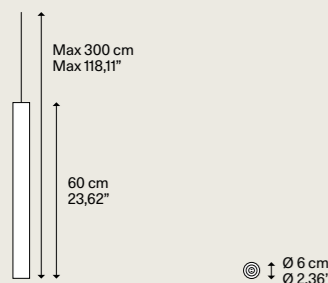

Net weight 1,42 kg / 3,13 lbs
Boxes Colli 1

Light source Sorgente luminosa

Medium Base E26 Par 16 LED
1 x max 8 W
120 V
W/L max 6 cm / W/L max 2,4"
Ø max 5 cm / Ø max 1,96"

Bulb not included
Lampadina non inclusa

Metal structure Montatura in metallo

Matte White - 9010 Bianco Opaco - 9010	09623 1000U
Matte Black - 9005 Nero Opaco - 9005	09623 2000U
Coppery Bronze Bronzo Ramato	09623 3500U

IP20 Energy Saving Dim

A-Tube small

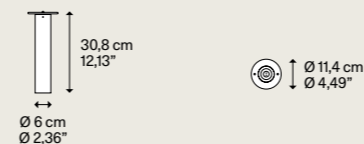

Net weight 0,80 kg / 1,76 lbs
Boxes Colli 1
Mounts directly to a 4" Standard J-Box - Plate Adaptor included *

Light source Sorgente luminosa

Medium Base E26 Par 16 LED
1 x max 8 W
120 V
W/L max 6 cm / W/L max 2,4"
Ø max 5 cm / Ø max 1,96"

Bulb not included
Lampadina non inclusa

Metal structure Montatura in metallo

Matte White - 9010 Bianco Opaco - 9010	09632 1000U
Matte Black - 9005 Nero Opaco - 9005	09632 2000U
Coppery Bronze Bronzo Ramato	09632 3500U

IP20 Energy Saving Dim

A-Tube large

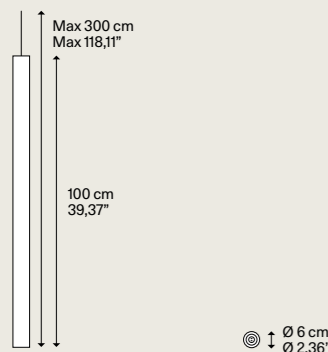

Net weight 1,87 kg / 4,12 lbs
Boxes Colli 1

Light source Sorgente luminosa

Medium Base E26 Par 16 LED
1 x max 8 W
120 V
W/L max 6 cm / W/L max 2,4"
Ø max 5 cm / Ø max 1,96"

Bulb not included
Lampadina non inclusa

Metal structure Montatura in metallo

Matte White - 9010 Bianco Opaco - 9010	09624 1000U
Matte Black - 9005 Nero Opaco - 9005	09624 2000U
Coppery Bronze Bronzo Ramato	09624 3500U

IP20 Energy Saving Dim

A-Tube medium

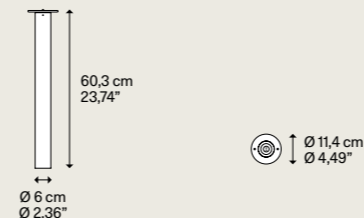

Net weight 0,90 kg / 1,98 lbs
Boxes Colli 1
Mounts directly to a 4" Standard J-Box - Plate Adaptor included *

Light source Sorgente luminosa

Medium Base E26 Par 16 LED
1 x max 8 W
120 V
W/L max 6 cm / W/L max 2,4"
Ø max 5 cm / Ø max 1,96"

Bulb not included
Lampadina non inclusa

Metal structure Montatura in metallo

Matte White - 9010 Bianco Opaco - 9010	09633 1000U
Matte Black - 9005 Nero Opaco - 9005	09633 2000U
Coppery Bronze Bronzo Ramato	09633 3500U

IP20 Energy Saving Dim

A-Tube large

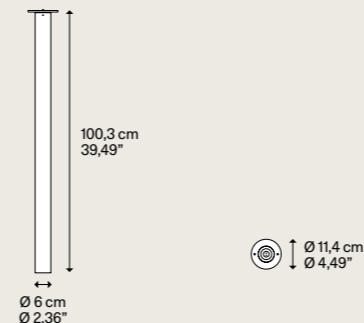

Net weight 1,50 kg / 3,31 lbs
Boxes Colli 1
Mounts directly to a 4" Standard J-Box - Plate Adaptor included *

Light source Sorgente luminosa

Medium Base E26 Par 16 LED
1 x max 8 W
120 V
W/L max 6 cm / W/L max 2,4"
Ø max 5 cm / Ø max 1,96"

Bulb not included
Lampadina non inclusa

Metal structure Montatura in metallo

Matte White - 9010 Bianco Opaco - 9010	09634 1000U
Matte Black - 9005 Nero Opaco - 9005	09634 2000U
Coppery Bronze Bronzo Ramato	09634 3500U

IP20 Energy Saving Dim

Suspension lamps must be installed on a canopy ▶ p. 426-433
Le lampade a sospensione devono essere installate su rosone ▶ p. 426-433

* Recessed backplate available upon request.

* Recessed backplate disponibile su richiesta.

Rain, *design by* Andrea Tosetto, 2015

Rain falls from the ceiling like a drop of spring rain, with a linear movement that accentuates the curvaceous conical forms of its body. A metal suspension lamp with an LED light source – simple and effective, elegant and extremely bright, to be used either independently or as a scenic composition.

● Spec sheet p. 253

Rain scende dal soffitto come una goccia di pioggia primaverile, con un movimento lineare che accentua le sinuose forme coniche del suo corpo. Una sospensione in metallo con sorgente luminosa a LED – semplice ed efficace, elegante ed estremamente luminosa, da usare da sola o in composizioni scenografiche.



RAIN	CATEGORY LAMP		TYPE OF LIGHT	
	Cluster suspension	Sospensione cluster	Symmetrical diffused light	Luce simmetrica diffusa







Rain, composition of 24 lights on a *round canopy*,
FINISHES Chrome + Brushed Chrome and Chrome + Rose Gold.



247 Cluster suspension lamp

Rain



Rain, composition of 5 lights on a *round canopy* and single lights on *recessed micro canopies*.

FINISHES Matte Black + Matte Black and Matte Black + Brushed Chrome, black cable and black structure version.



Rain, FINISH Chrome + Matte Black.



Rain, composition of 3 lights on a short track, FINISH Chrome + Coppery Bronze.

Rain, une goutte de pluie printanière descend du plafond, avec un mouvement linéaire qui accentue les sinueuses formes coniques de son corps. Une suspension en métal avec source lumineuse LED – simple et efficace, élégante et très lumineuse, à utiliser seule ou en compositions scénographiques. ● FR

Rain kommt von der Decke herab wie ein Regentropfen im Frühling, mit einer linearen Bewegung, die die geschwungenen, konischen Formen des Korpus betont. Eine Aufhängung aus Metall mit LED-Lichtquelle, einfach und effizient, elegant und besonders stark leuchtend, einzeln oder in wirkungsvollen Kombinationen zu verwenden. ● DE

Rain cae como una gota de lluvia primaveral del techo, con un movimiento lineal que acentúa las sinuosas formas cónicas de su cuerpo. Colgante de metal con fuente luminosa LED, simple y efectiva, elegante y extremadamente brillante, para usarla sola o en composiciones escénicas. ● ES

Светильник *Rain* спускается с потолка подобно капле весеннего дождя, прямолинейность падения которой оттеняет изгибы конических форм его корпуса. Металлический подвесной светильник с источником света LED – простой и эффективный, элегантный и необыкновенно яркий, для использования отдельно или в композициях со сценическим эффектом. ● RU

*Rain*就如从天花板上滴下的一滴春雨，以线性运动加重了其主体的弯曲圆锥形的外形。具有LED光源的金属悬架简单有效，优雅且非常明亮，可单独使用或在场景中组合使用。● ZH

CATEGORY CLUSTER SUSPENSION LAMP

DESIGN Andrea Tosetto, 2015

Rain

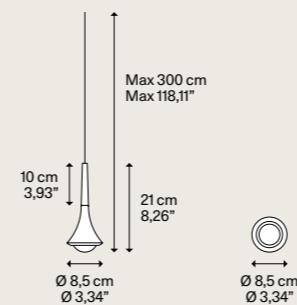

Light source
Sorgente luminosa

LED
3000 K
9 W
850 lm
120 V
CRI 92
MacAdam 3-Step

LED included
LED incluso

Net weight 0,34 kg / 0,75 lbs | Boxes 2

Metal structure
Montatura in metallo

Chrome
Cromo

Transparent cable
Cavo trasparente

Matte Black - 9005
Nero Opaco - 9005

Black cable
Cavo nero

Metal decor
Decoro in metallo

Matte Black - 9005
Nero Opaco - 9005 | 15621 2030U

Coppery Bronze
Bronzo Ramato | 15621 3530U

Brushed Chrome
Cromo Spazzolato | 15621 4730U

Gold
Oro | 15621 5030U

Rose Gold
Oro Rosa | 15621 5530U

Matte Black - 9005
Nero Opaco - 9005 | 15622 2030U

Coppery Bronze
Bronzo Ramato | 15622 3530U

Brushed Chrome
Cromo Spazzolato | 15622 4730U

Gold
Oro | 15622 5030U

Rose Gold
Oro Rosa | 15622 5530U

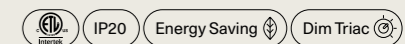

Suspension lamps must be installed on a canopy ▶ p. 426-433
Le lampade a sospensione devono essere installate su rosone ▶ p. 426-433

Rain ▶ Cluster suspension lamp



Transparent cable and chrome structure

Black cable and black structure



▶ LED sources with direct power supply to the AC line voltage – driver not required. Dimmable with phase cut dimmer.

▶ LED con alimentazione diretta a tensione di rete – non necessita di driver. Dimmerabile con varialuce a taglio di fase.

Spider, design by Andrea Tosetto, 2015/2022

Spider is a round suspension lamp resembling an eye that can look into any part of the room. By adjusting the angle of the diffuser, the light beam emitted by the LED light can be directed towards any specific point. When installed on the different clusters available, it can create numerous lighting patterns, from functional to decorative, which can be dimmed at will. Available in the new *Terra* finish and as ceiling light. In *Spider*, the simplicity of the looks underscores the versatility of its performance.

● Spec sheet p. 269

Spider è una lampada a sospensione sferica che ricorda un occhio che può guardare in qualsiasi punto della stanza. Regolando l'angolo del diffusore si può infatti dirigere il fascio di luce a LED su un particolare punto di interesse, mentre montata sui diversi cluster disponibili può creare molteplici schemi di luce, dal funzionale al decorativo, dimmerabili a piacere. Disponibile nella nuova finitura *Terra* e nella versione a soffitto. In *Spider*, la semplicità della forma esalta la versatilità delle prestazioni.

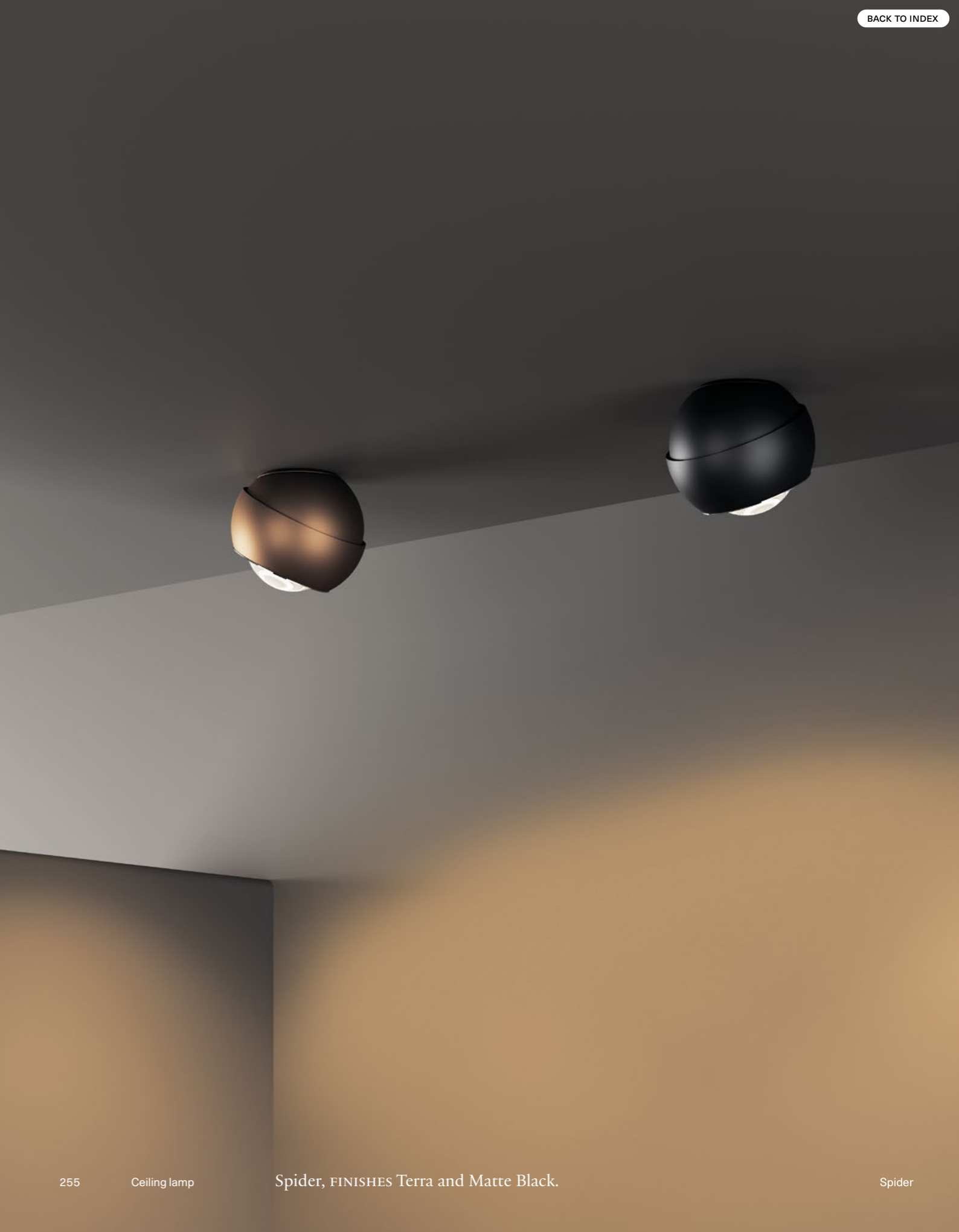

SPIDER	CATEGORY LAMP		TYPE OF LIGHT	
	Cluster suspension Ceiling	Sospensione cluster Soffitto	Symmetrical diffused light Adjustable	Luce simmetrica diffusa Orientabile

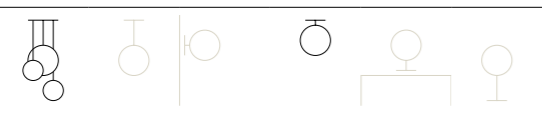



Spider, single light on wall-mounted *radial canopy* and composition of 6 lights on *radial canopy*, FINISHES Matte White and Chrome.



Spider, single light on wall-mounted *radial canopy*, FINISH Matte White.



1



2



3

259

Cluster suspension lamp, Ceiling lamp

- 1 Spider, FINISH Matte White.
- 2 Spider, FINISH Matte Black.
- 3 Spider, FINISH Matte Champagne.







Spider, FINISHES Terra and Matte Black.
CENTRE: Spider, composition of 4 lights on *radial canopy*.



Matte White

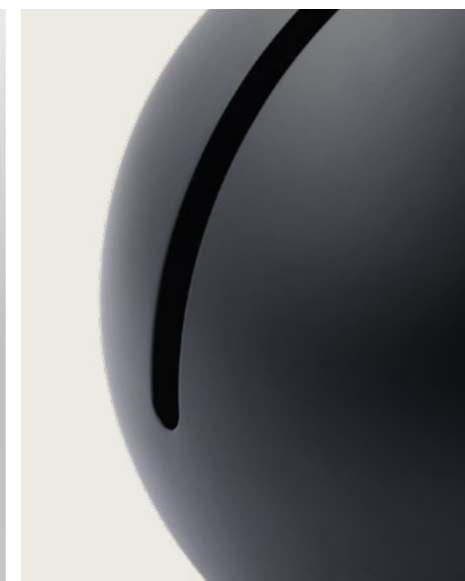

Matte Black

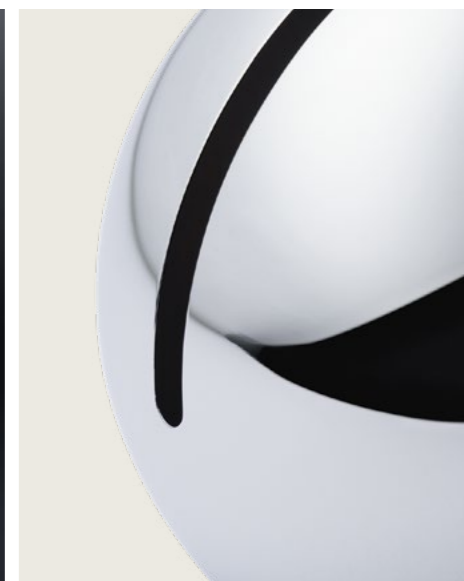

Chrome



Matte Champagne



Gold



Rose Gold



Terra

Spider est une suspension sphérique qui fait penser à un œil qui peut regarder n'importe où dans la pièce. En réglant l'angle du diffuseur, vous pouvez en effet diriger le faisceau de lumière LED vers un point d'intérêt particulier, tandis que montée sur les différents clusters disponibles, elle peut créer plusieurs schémas d'éclairage, du fonctionnel au décoratif, variables à souhait. Maintenant disponible dans la nouvelle finition Terra et en version plafonnrière. Dans *Spider*, la simplicité de la forme met en valeur la polyvalence des performances. ●FR

Spider ist eine kugelförmige Hängeleuchte, die an ein Auge erinnert, das jeden Punkt im Raum erblicken kann. Durch Einstellen des Winkels des Diffusors kann der LED-Lichtstrahl tatsächlich auf eine spezielle Stelle gerichtet werden, während durch die Kombination zu unterschiedlichen verfügbaren Clustern verschiedene Lichtschemata erstellt werden können - von funktionell bis dekorativ und nach Belieben dimmbar. Jetzt in der neuen Ausführung Terra und in der Deckenversion erhältlich. Bei *Spider* betont die Einfachheit der Form die vielseitigen Leistungen. ●DE

Spider es una lámpara colgante esférica que recuerda un ojo que puede mirar a cualquier punto de la habitación. Regulando el ángulo del difusor, de hecho, se puede dirigir el haz de luz de LED en un punto particular de interés, mientras que instalada en los diferentes sistemas cluster disponibles puede crear múltiples esquemas de luz, desde el funcional al decorativo, regulable a gusto. Ahora disponible en el nuevo acabado Terra y en la versión de techo. En *Spider*, la simplicidad de la forma exalta la versatilidad de las prestaciones. ●ES

Spider – это сферический подвесной светильник, напоминающий глаз, который может смотреть в любую точку помещения. Регулируя угол диффузора, можно направлять пучок светодиодного света на конкретную точку, а при установке в различных кластерах – создавать разнообразные схемы освещения, от функционального до декоративного, с возможностью регулировки яркости. Сейчас лампа выпускается с новой отделкой Terra и в форме потолочного плафона. Простота формы *Spider* подчеркивает его универсальность. ●RU

Spider 是一款球形吊灯，像一只眼睛，可以望向房间里的每一个角落。调节灯罩的角度，可以把LED灯的光束调向特定角度，如安装在不同的组合吊上，可营造多重光幕，可满足从功能性到装饰性的需求，并根据喜好调光。吸顶灯版本的大地色饰面如今也可提供。*Spider*的简单造型彰显了其性能的广泛用途。●ZH

CATEGORY CLUSTER SUSPENSION LAMP

Spider

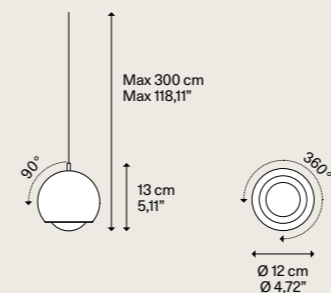

Light source Sorgente luminosa

LED 3000 K
10 W
980 lm
120 V
CRI 92
MacAdam 3-Step

LED included
LED incluso

Net weight 0,80 kg
Peso netto 1,76 lbs
Boxes 2
Colli 2

DESIGN Andrea Tosetto, 2015

Metal structure Montatura in metallo

Chrome Cromo

Metal diffuser Diffusore in metallo

Matte White-9010
Bianco Opaco-9010

Matte Black-9005
Nero Opaco-9005

Chrome Cromo

Matte Champagne
Champagne Opaco

Gold Oro

Rose Gold
Oro Rosa

Terra Terra

Code Codice

16020 1030U

16020 2030U

16020 4030U

16020 4530U

16020 5030U

16020 5530U

16020 6730U

Adjustable light Luce orientabile



Energy Saving
Dim Triac

Suspension lamps must be installed on a canopy ▶ p. 426-433
Le lampade a sospensione devono essere installate su rosone ▶ p. 426-433

CATEGORY CEILING LAMP

Spider

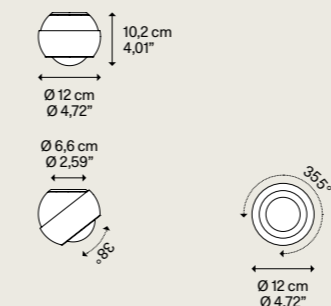

Light source Sorgente luminosa

LED 3000 K
10 W
980 lm
120 V
CRI 92
MacAdam 3-Step

LED included
LED incluso

Net weight 0,86 kg
Peso netto 1,89 lbs
Boxes 2
Colli 2
Mounts directly to a 4" Standard J-Box - Plate Adaptor included *

DESIGN Andrea Tosetto, 2022

Metal structure Montatura in metallo

Chrome Cromo

Metal diffuser Diffusore in metallo

Matte White-9010
Bianco Opaco-9010

Matte Black-9005
Nero Opaco-9005

Extra Matte Champagne
Champagne Extra Opaco

Terra Terra

Code Codice

18340 1030U

18340 2030U

18340 4530U

18340 6730U

Adjustable light Luce orientabile



Energy Saving
Dim Triac
EAC

▶ LED sources with direct power supply to the AC line voltage - driver not required. Dimmable with phase cut dimmer. ▶ * Recessed backplate available upon request. ▶ LED con alimentazione diretta a tensione di rete - non necessita di driver. Dimmerabile con varialuce a taglio di fase. ▶ * Recessed backplate disponibile su richiesta.

Spider ▶ Cluster suspension lamp

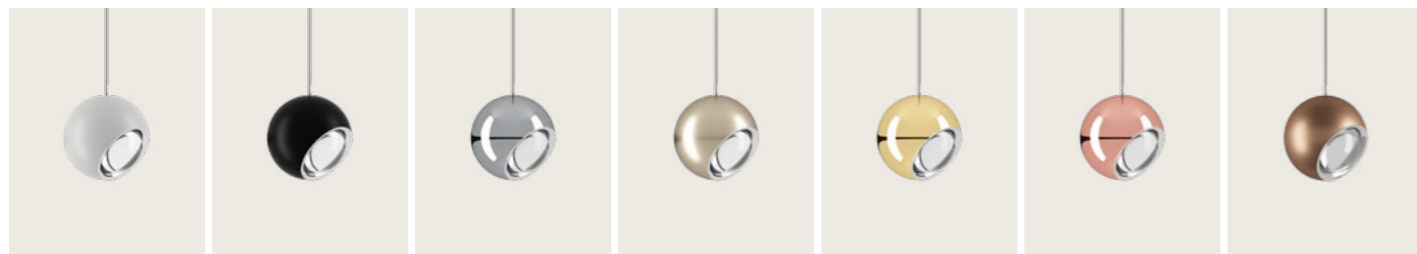

Spider ▶ Ceiling lamp

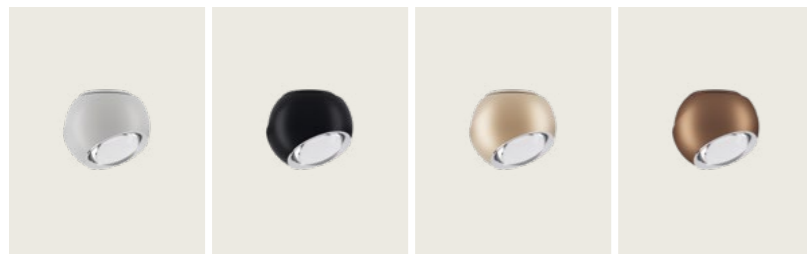

Kelly Cluster, *design by* Andrea Tosetto, 2015

Kelly Cluster spectacularly reinterprets the creative intuition of the family of *Kelly* lights in a sculptural and extremely compact sphere, mounted on a canopy and allowing multiple different compositions at will. A suspension lamp in metal, characterised by its lightness and vibrancy thanks to the unique laser cuts that create captivating plays of light and shadow, it is available in four different finishes bringing any space to life.

● Spec sheet p. 279

Kelly Cluster riformula brillantemente l'intuizione creativa della famiglia di lampade *Kelly* in una sfera sculturale ed estremamente compatta che, montata su rosone, permette di realizzare composizioni multiple a piacere. Lampada a sospensione in metallo, leggera e vivace grazie ai particolari tagli a laser che creano affascinanti giochi di luci e ombre, è disponibile in quattro diverse finiture in grado di far risaltare qualsiasi ambiente.



KELLY CLUSTER	CATEGORY LAMP		TYPE OF LIGHT	
	Cluster suspension	Sospensione cluster	Symmetrical diffused light	Luce simmetrica diffusa









Kelly Cluster reformule brillamment l'intuition créative de la famille de lampes *Kelly* dans une sphère sculpturale et extrêmement compacte qui, montée sur une patère, permet de réaliser d'innombrables compositions. Lampe à suspension en métal, légère et animée grâce aux originales découpes laser qui créent de fascinants jeux de lumière et d'ombres ; plusieurs finitions disponibles pour valoriser tous les espaces. ● FR

Kelly Cluster formuliert die kreative Intuition der Leuchtenfamilie *Kelly* auf brillante Weise in einer skulpturellen und besonders kompakten Kugel wieder, die auf einem Baldachin montiert die Umsetzung verschiedener Kombinationen nach Wahl ermöglicht. Hängeleuchte aus Metall, die dank besonderer Laserschnitte leicht und lebhaft ist. Sie sorgen außerdem für faszinierende Spiele aus Licht und Schatten. Die Leuchte ist in vier verschiedenen Ausführungen erhältlich, um jeden Raum aufzuwerten. ● DE

Kelly Cluster reformula brillantemente la intuición creativa de la familia de lámparas *Kelly* en una esfera escultural y extremadamente compacta que, montada en un florón, permite crear múltiples composiciones a voluntad. Lámpara colgante de metal, ligera y alegre gracias a los cortes especiales de láser que crean fascinantes juegos de luz y sombra, está disponible en cuatro acabados diferentes capaces de resaltar cualquier ambiente. ● ES

Kelly Cluster блестяще обыгрывает в новом ключе творческую интуицию, воплощенную в семействе светильников *Kelly*, выполненных в скульптурной и необыкновенно компактной форме шара, монтируя который на потолочное крепление можно создавать множественные композиции на свой вкус. Металлический подвесной светильник с изящным и динамичным дизайном благодаря особым прорезям, выполненным методом лазерной резки и создающим чарующую игру света и тени, доступен в четырёх разных вариантах отделки, которые украсят любой интерьер. ● RU

*Kelly Cluster*在一个雕塑般紧凑的球体中巧妙地重新构造了*Kelly*灯家族系列的创意直觉，该球体安装在底盘上，可让您根据需要创建多种组合。金属制成的吊灯，光线明亮、活泼，这要归功于其特殊的激光切割工艺，可以产生引人入胜的光影效果，并提供四种不同的颜色，可以烘托任何环境。● ZH

CATEGORY CLUSTER SUSPENSION LAMP

Kelly Cluster

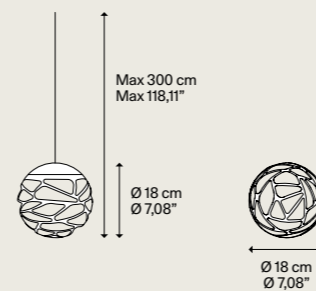

DESIGN Andrea Tosetto, 2015

Metal structure
Montatura in metallo

- Matte White - 9010
Bianco Opaco - 9010
- Matte Black - 9005
Nero Opaco - 9005
- Coppery Bronze
Bronzo Ramato
- Matte Champagne
Champagne Opaco

Glass diffuser
Diffusore in vetro

- Glossy White
Bianco Lucido

Code
Codice

- 14710 1030U
- 14710 2030U
- 14710 3530U
- 14710 4530U

Light source
Sorgente luminosa

LED
3000 K
9 W
850 lm
120 V
CRI 92
MacAdam 3-Step

LED included
LED incluso

Net weight 1,00 kg
Peso netto 2,20 lbs

Boxes 1
Colli 1

IP20 Energy Saving Dim Triac

Suspension lamps must be installed on a canopy ► p. 426-433
Le lampade a sospensione devono essere installate su rosone ► p. 426-433

Kelly Cluster ▾ Cluster suspension lamp

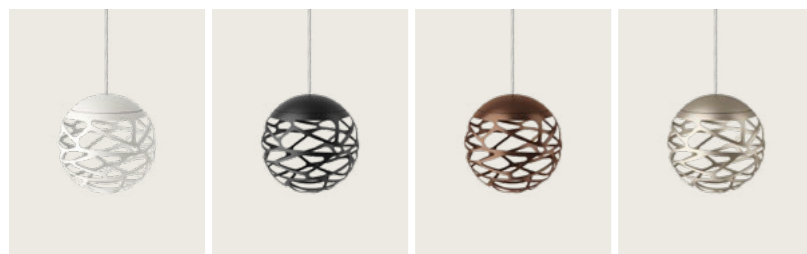

► LED sources with direct power supply to the AC line voltage – driver not required.
Dimmable with phase cut dimmer.

► LED con alimentazione diretta a tensione di rete – non necessita di driver.
Dimmerabile con varialuce a taglio di fase.

Out of Scale

'*Out of Scale*' elevates the concept of '*Standard Bespoke*' to the pinnacle of personalisation and freedom of expression. Light compositions become bespoke solutions for any space: thanks to the flexibility offered by the combinations of lamps and canopies, the possibilities are endless, and the solutions are entirely personalised. By developing unprecedented configurations of shapes and sizes, *Lodes* can meet the needs of any space and creative project, furnishing environments with a luminous scenography capable of making a significant impact.

"Out of Scale" eleva il concetto di "*Standard Bespoke*" alla massima personalizzazione e libertà espressiva. Le composizioni di luce diventano risposte su misura per qualsiasi spazio: grazie alla flessibilità offerta dalle combinazioni tra lampade e rosoni, le applicazioni diventano infinite e le soluzioni completamente personalizzate. Sviluppando inedite configurazioni di forme e dimensioni, *Lodes* può soddisfare le esigenze di qualsiasi spazio e progetto creativo per arredare ogni ambiente con una scenografia luminosa in grado di fare la differenza.

Out of Scale

Endless applications

Lodes can design *tailor-made solutions* for any type of environment, regardless of its size or complexity, offering personalised systems that enhance the architectural forms of the space and meet the specific requirements of each customer.

Lodes può progettare la *soluzione su misura* per ogni tipo di ambiente, indipendentemente dalle sue dimensioni o dalla sua complessità, per proporre sistemi personalizzati in grado di valorizzare le forme architettoniche dello spazio e di rispondere alle richieste specifiche di ciascun cliente.

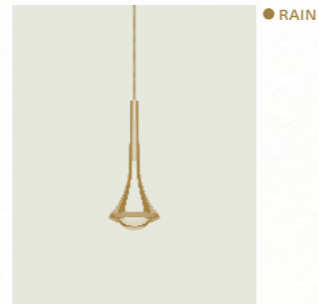
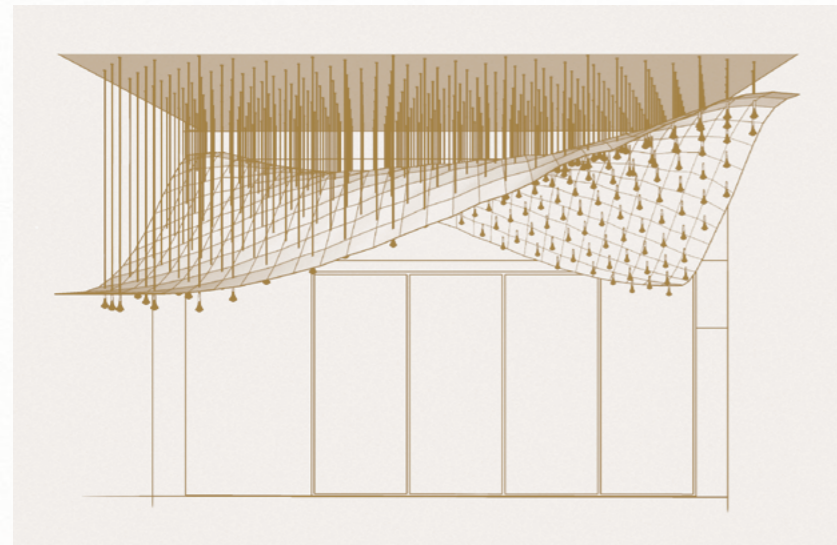
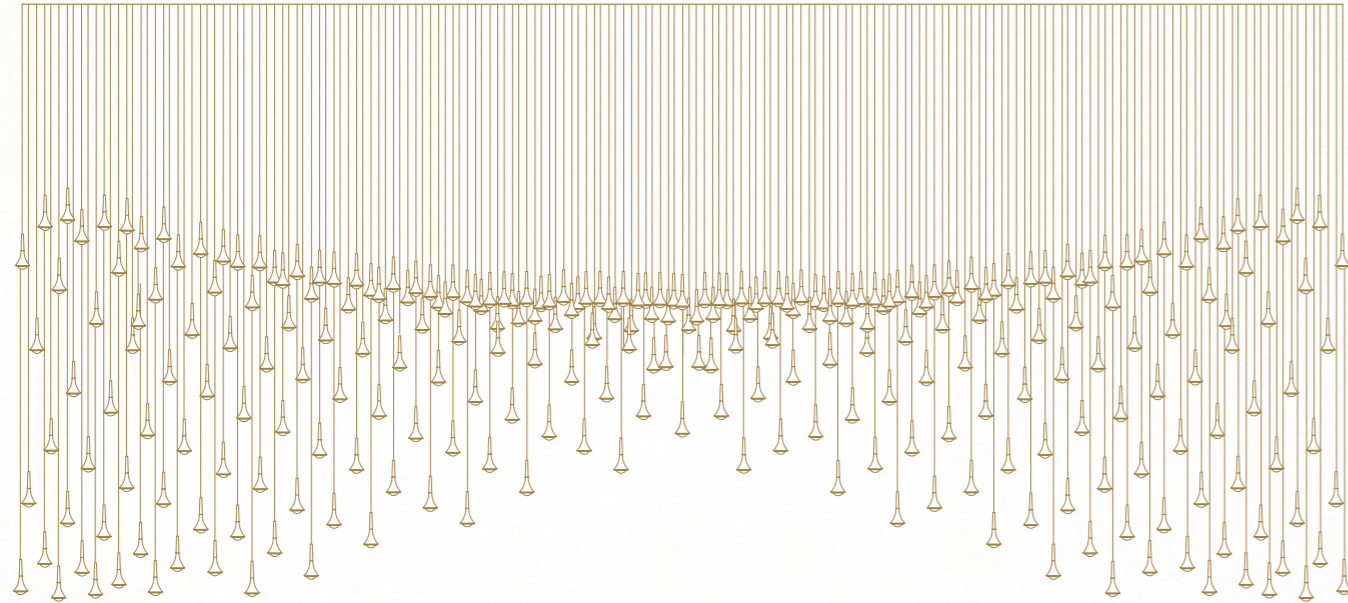

● RAIN

REQUEST	Composition in an entrance area
ARRANGEMENT	Wave effect
TYPE OF CANOPY	Recessed Micro
PRODUCT	Rain
QUANTITY	250-300 pcs
COMPOSITION HEIGHT	6,5 m

The Fullerton Ocean Park Hotel—Hong Kong

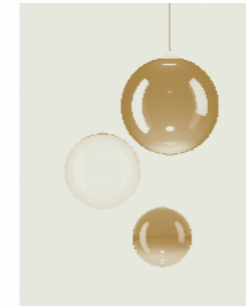

● RANDOM SOLO



INTERIOR DESIGNER: EM BESPOKE – PH: ALEX LEUNG

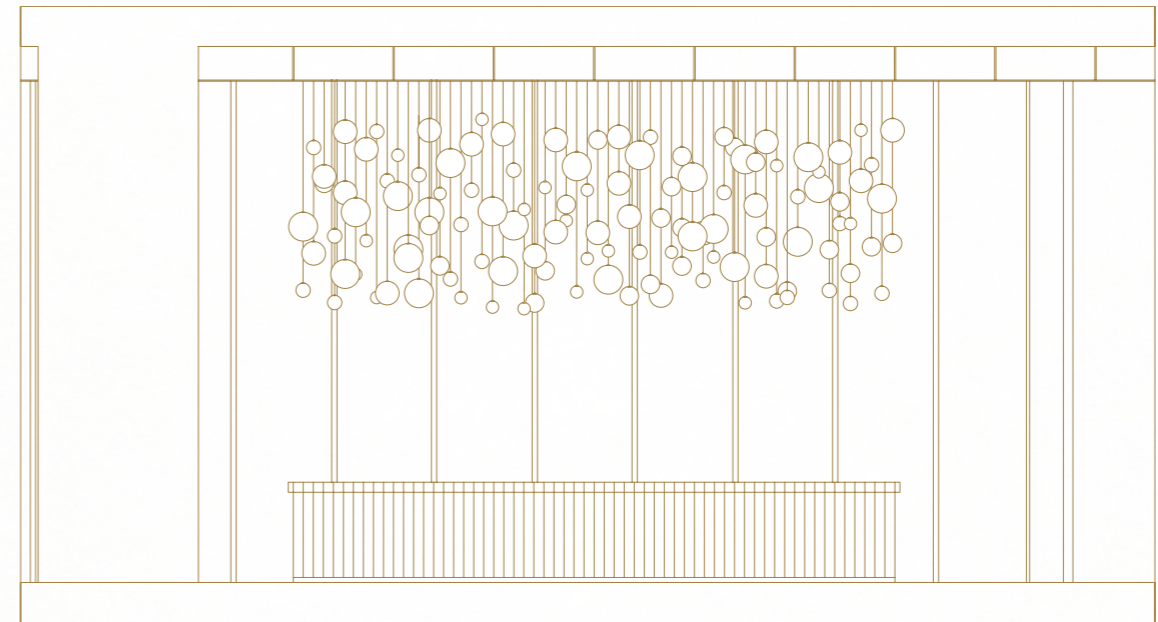

REQUEST	Composition in a hotel lobby
ARRANGEMENT	Staggered
TYPE OF CANOPY	Recessed Micro
PRODUCT	Random Solo
QUANTITY	120 pcs
FINISHES	Mix of finishes and sizes
COMPOSITION HEIGHT	5 m
HEIGHT OF LOWER LAMP	2,7 m

Penn State Health, Hampden Medical Center—Enola, Pennsylvania, USA

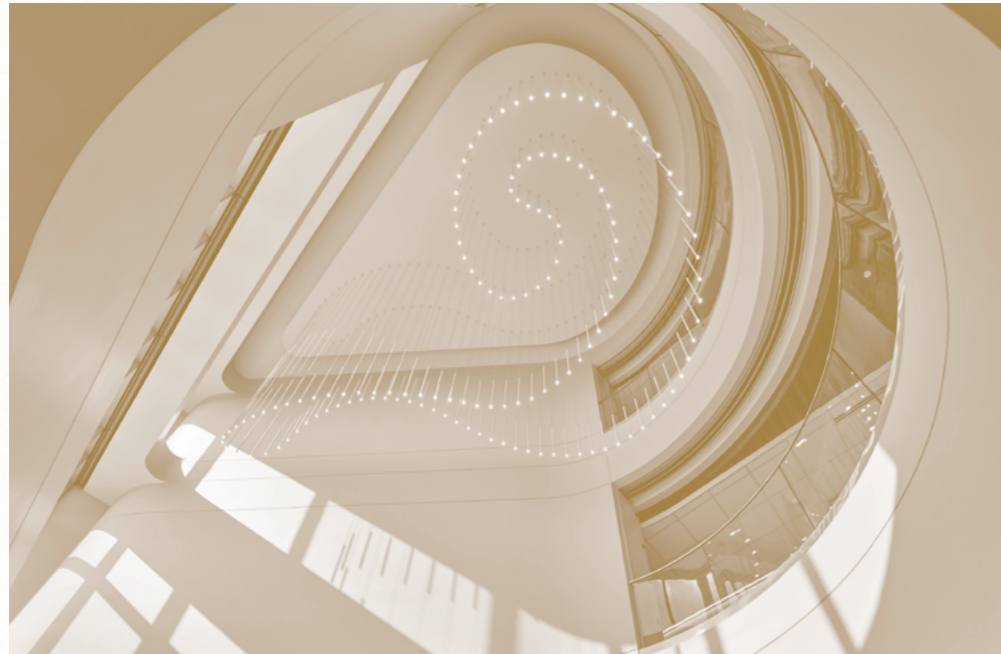

PROJECT BY: CANNONDESIGN, INC. – PH: TODD MASON@HALKIN MASON PHOTOGRAPHY

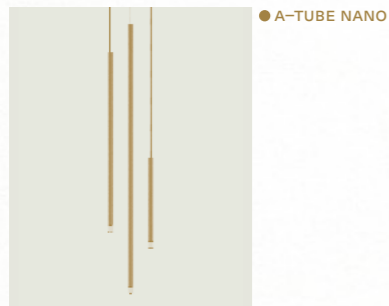

● A-TUBE NANO

REQUEST	Composition in a medical center
ARRANGEMENT	Golden rule spiral
TYPE OF CANOPY	Recessed Micro
PRODUCT	A-Tube Nano



Luminare, Luxury Residence—Brisbane, Australia



PROJECT BY: CAVCORP – PH: BROCK BEAZLEY



● VOLUM

REQUEST	Composition in the lobby
ARRANGEMENT	Staggered
TYPE OF CANOPY	Mix of single canopies
PRODUCT	Volum
QUANTITY	about 50 PCS
FINISHES	Glossy White

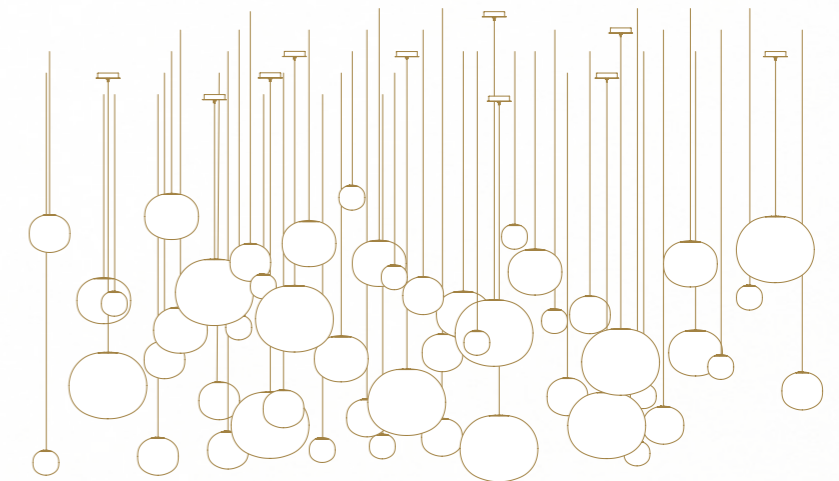

Out of Scale provides limitless application possibilities without compromising on the number of light sources or the *functionality* of the system. Different combinations can be configured with standard products or personalised creations to meet the requirements of any project, even the most daring ones.

Out of Scale offre infinite possibilità di applicazione, senza compromessi sul numero di fonti di luce da inserire o sulla *funzionalità* del sistema. Le diverse combinazioni possono essere configurate con prodotti standard o con creazioni su misura per soddisfare i requisiti di qualsiasi progetto, anche di quelli più audaci.

Unprecedented configurations in terms of shape and size come to life in Lodes' studios, where interior designers craft tailor-made lighting projects based on the environment and the client's preferences to create a *luminous and decorative scenography* that maximises the potential of each space.

Configurazioni inedite per forma e dimensione prendono vita negli studi di Lodes, dove gli interior designer studiano progetti di luce su misura a seconda dell'ambiente e dei desideri del committente per elaborare una *scenografia luminosa e decorativa* che valorizzi ogni spazio al massimo delle sue potenzialità.

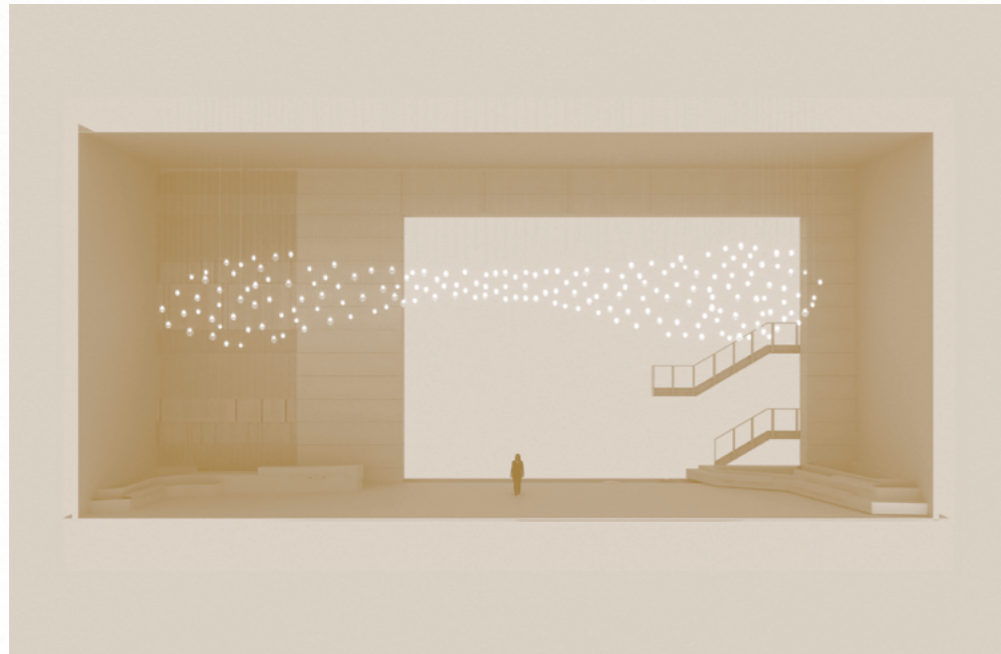

REQUEST	Composition in an entrance area
ARRANGEMENT	Cloud effect
TYPE OF CANOPY	Recessed Micro
PRODUCT	Random Solo
QUANTITY	200 PCS
COMPOSITION HEIGHT	10,2 m
HEIGHT OF LOWER LAMP	6 m

● RANDOM SOLO



REQUEST	Composition in an entrance area/Stairwell
ARRANGEMENT	Clustered
TYPE OF CANOPY	Recessed Micro
PRODUCT	A-Tube Nano Duo
QUANTITY	60 PCS
COMPOSITION HEIGHT	7,7 m
HEIGHT OF LOWER LAMP	3,4 m

● A-TUBE NANO DUO

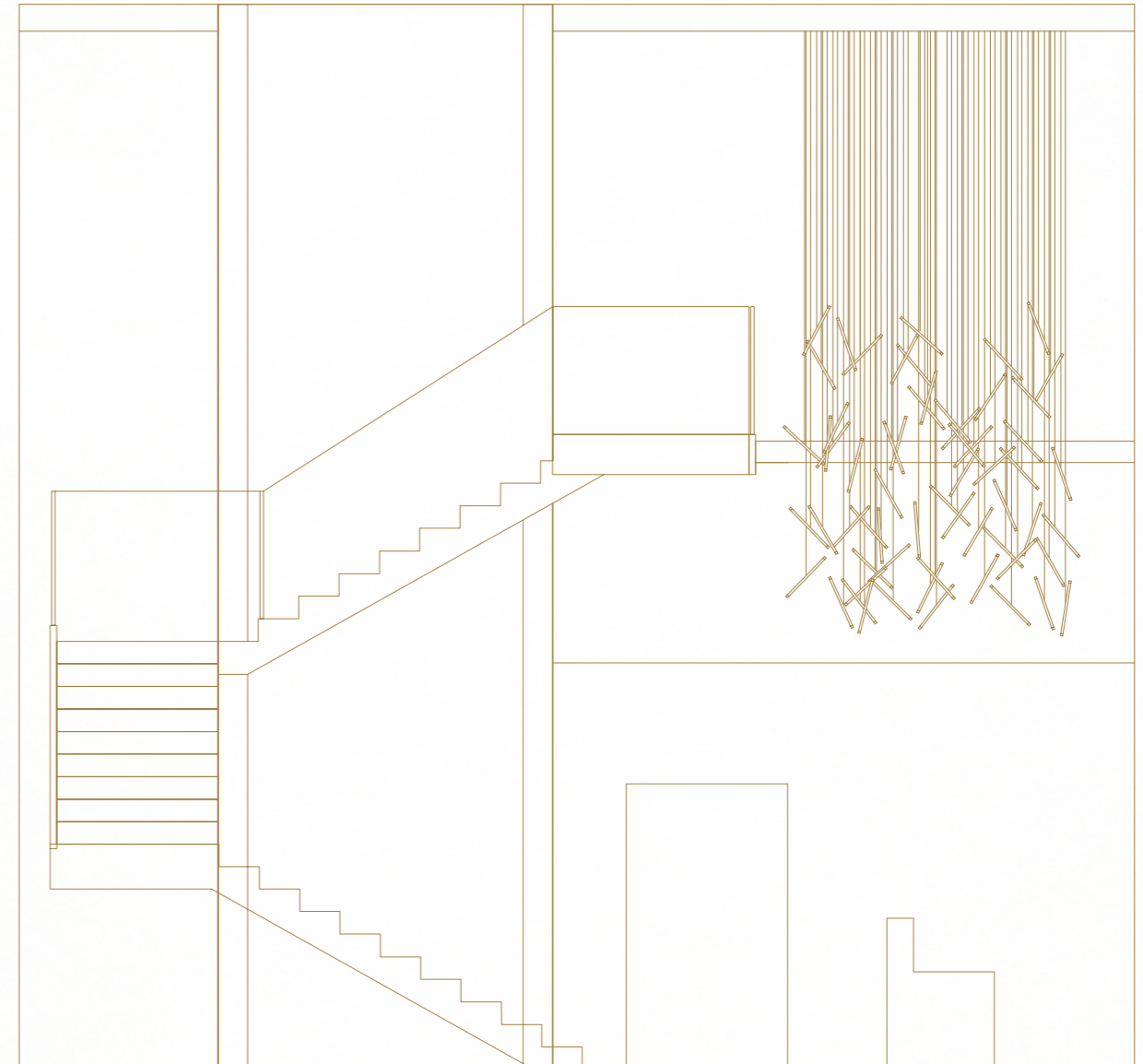

Endless applications

One output



Tidal, *design by* Needs Studio, 2023

Tidal is a ring-shaped ceiling lamp that evokes the motion of the tide and celestial bodies. Its fluid and oval design mimics wave movements and tidal changes, with one side wider than the other, appearing differently to the viewer depending on their position under the lamp. The die-cast aluminium body projects light up and down at the same time. The ring discreetly hides all the technical elements inside the design, enhancing the object's aesthetic value. Measuring 60 cm, *Tidal* is available in four matte finishes: white and the new black finish, suited to minimalist interiors, terra and champagne, which offer a more decorative touch for embellishing spaces with their warm and elegant tones.

● Spec sheet p. 291

Tidal è una lampada da soffitto a forma di anello che rimanda all'effetto del moto della marea e ai corpi celesti. Il suo design fluido e ovale imita il movimento delle onde e il cambiamento dettato dalla marea, con un lato più largo dell'altro, che appare diverso all'utente a seconda della sua posizione nel guardare la lampada da sotto. La scocca del corpo lampada è realizzata in pressofusione di alluminio, proietta contemporaneamente la luce sia verso il basso che verso l'alto. L'anello nasconde discretamente tutti gli elementi tecnici all'interno, enfatizzando così il valore estetico dell'oggetto. Con una dimensione di 60 cm, *Tidal* è disponibile in quattro finiture opache, bianco, terra, champagne e ora anche in nero. Mentre il bianco e il nero si adattano a interni minimalisti, le tonalità terra e champagne offrono un tocco più decorativo, arricchendo gli spazi con i loro toni caldi ed eleganti.



TIDAL	CATEGORY LAMP		TYPE OF LIGHT	
	Ceiling	Soffitto	Symmetrical diffused light	Luce simmetrica diffusa

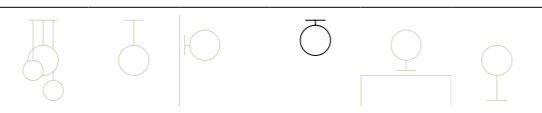







1



2



3

- 1 Tidal, FINISH Matte Champagne.
- 2 Tidal, FINISH Terra.
- 3 Tidal, FINISH Matte Black.

Tidal est un plafonnier en forme d'anneau qui évoque le mouvement de la marée et des corps célestes. Son design fluide et ovale évoque le mouvement des vagues et le changement rythmé par la marée, avec un côté plus large que l'autre, qui apparaît différent selon le point où se trouve l'utilisateur lorsqu'il regarde la lampe par dessous. La coque du corps de la lampe, en aluminium moulé sous pression, projette simultanément la lumière vers le bas et vers le haut. L'anneau dissimule discrètement tous les éléments techniques et souligne ainsi la valeur esthétique de l'objet. Dans sa dimension de 60 cm, *Tidal* est disponible en quatre finitions mates : blanc, terre, champagne et désormais même en noir. Le blanc et le noir épousent parfaitement les intérieurs minimalistes, alors que les tonalités terre et champagne se proposent dans une touche plus décorative, enrichissant les espaces de leurs nuances chaudes et élégantes. ●FR

Tidal ist eine Deckenleuchte in Form eines Ringes, die auf den Effekt der Bewegung der Gezeiten und der Himmelskörper verweist. Ihr harmonisches und ovales Design ahmt die Bewegung der Wellen und den von den Gezeiten diktierten Wechsel nach, wobei eine Seite breiter als die andere ist und dem Benutzer je nach Position, beim Betrachten der Leuchte von unten, unterschiedlich erscheint. Der Körper der Leuchte, gefertigt aus Aluminiumdruckguss, projiziert das Licht gleichzeitig nach unten und nach oben. Der Ring verbirgt diskret alle technischen Elemente im Inneren und unterstreicht so den ästhetischen Wert des Objekts. Mit einer Abmessung von 60 cm ist *Tidal* in vier satinierten Ausführungen erhältlich: Weiß, Terra, Champagne und jetzt auch in Schwarz. Während Weiß und Schwarz zu minimalistischen Inneneinrichtungen passen, bieten die Farbtöne Terra und Champagner einen dekorativeren Touch und bereichern die Räume mit ihren warmen und eleganten Tönen. ●DE

Tidal es una lámpara de techo con forma de anillo que evoca el efecto del movimiento de la marea y los cuerpos celestes. Su diseño fluido y ovalado imita el movimiento de las olas y el cambio que dicta la marea, con un lado más ancho que otro que el usuario ve diferente dependiendo de su posición a la hora de mirar la lámpara desde abajo. El armazón del cuerpo de la lámpara de aluminio moldeado a presión proyecta simultáneamente la luz tanto hacia abajo como hacia arriba. El anillo oculta discretamente todos los elementos técnicos en su interior y de esta forma enfatiza el valor estético del objeto. Con un tamaño de 60 cm, *Tidal* está disponible en cuatro acabados mate, blanco, tierra, champán y ahora también negro. Mientras que el blanco y el negro se adaptan a interiores minimalistas, los tonos tierra y champán aportan un toque más decorativo y enriquecen los espacios con sus tonos cálidos y elegantes. ●ES

Tidal – это потолочный светильник в форме кольца, воссоздающий эффект движения прилива и небесных тел. Его струящаяся и овальная форма имитирует движения волн и изменения, создаваемые приливом, с одной более широкой стороной, которая меняется в зависимости от положения смотрящего на лампу снизу. Корпус светильника выполнен из литого под давлением алюминия, он одновременно проецирует свет в направлении вниз и вверх. Кольцо скрывает все технические компоненты внутри, подчеркивая эстетическую красоту предмета. Размером 60 см, *Tidal* выпускается в четырех вариантах матовой отделки, белого цвета, цвета «terra», «champagne», к которым сейчас добавился черный цвет. Белый и черный прекрасно сочетаются с минималистским интерьером, а тональности «terra» и «champagne» предлагают более декоративный стиль, обогащая пространство теплыми и элегантными тонами. ●RU

*Tidal*是一款指射潮汐与天体运动效果的环形吸顶灯。它的椭圆形流体设计模仿海浪的运动与潮汐引起的变化，一侧较另一侧更宽，从下方看灯体时会根据用户所在位置而显示有所不同。灯体外壳由压铸铝制成，可同时向下和向上投射光线。圆环将所有技术元件谨慎隐藏在內，从而彰显了这款灯品的美学价值。以其60厘米的尺寸，*Tidal*提供白色、大地色、香槟色和全新黑色这四种哑光饰面。白色和黑色适宜极简主义的内饰，大地色和香槟色的色调更具装饰性，以其温暖优雅的色调使空间得以丰富。●ZH

CATEGORY CEILING LAMP

Tidal

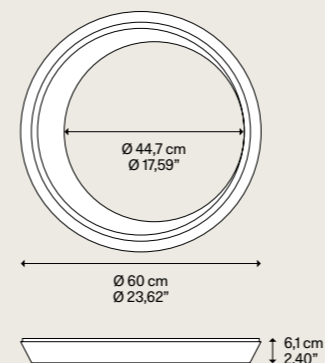

Net weight	3,90 kg	Boxes	1
Peso netto	8,60 lbs	Colli	

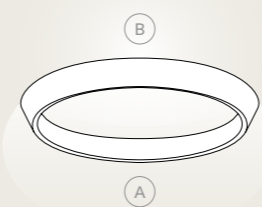
Light emission
Emissione luminosa

A ▶ 75%	Direct light emission Emissione di luce diretta
B ▶ 25%	Indirect light emission Emissione di luce indiretta

DESIGN Needs Studio, 2023

Metal structure Montatura in metallo	Code Codice
Matte White – 9010 Bianco Opaco – 9010	19930 1030U
Matte Black – 9005 NEW Nero Opaco – 9005	19930 2030U
Matte Champagne Champagne Opaco	19930 4530U
Terra Terra	19930 6730U

Light source
Sorgente luminosa

LED
3000 K
38 W
6860 lm
120-277 V
700 mA
CRI 90
MacAdam 3-Step

LED and driver included
LED e driver inclusi

Tidal ▾ Ceiling lamp



Nautilus, Nautilus Mini, *design by* Andrea Tosetto, 2017/2020

Strong design and leading-edge technology come together in this family of lamps characterised by a convex lens that projects the LED light wherever its needed or most preferred, for a truly efficient and personalised result. Versatile and dynamic, either on the wall or ceiling in a variety of versions and finishes, *Nautilus* lamps satisfy a full range of lighting needs, whether functional or purely decorative, in both residential and professional contexts.

● Spec sheet p. 309

Design deciso e tecnologia di punta si fondono in questa famiglia di lampade caratterizzate da una lente convessa che proietta la luce a LED dove serve o dove piace di più, per un risultato di efficienza e personalizzazione. Versatili e dinamiche, a parete o a soffitto, in diverse versioni e finiture, le lampade *Nautilus* soddisfano innumerevoli esigenze di illuminazione, dalle più funzionali a quelle particolarmente decorative, sia in ambito residenziale che professionale.



NAUTILUS	CATEGORY LAMP		TYPE OF LIGHT	
	Wall Ceiling	Parete Soffitto	Symmetrical diffused light Adjustable	Luce simmetrica diffusa Orientabile

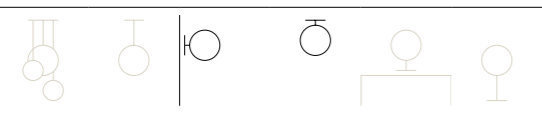









1



2



3



4

- 1 Nautilus, FINISH Matte White.
- 2 Nautilus, FINISH Chrome.
- 3 Nautilus, FINISH Matte Champagne.
- 4 Nautilus, FINISH Matte Black.



301

Wall lamp, Ceiling lamp

Nautilus, FINISH Matte White.

Nautilus







1



2



3

- 1 Nautilus Mini, FINISH Matte White.
- 2 Nautilus Mini, FINISH Matte Champagne.
- 3 Nautilus Mini, FINISH Matte Black.

Un design impeccable et une technologie de pointe fusionnent pour cette famille de lampes caractérisées par un verre convexe qui dirige la lumière à LED où il le faut et où vous le souhaitez le plus, pour un résultat efficace et personnalisé. Polyvalentes et dynamiques, appliques ou plafonniers, en différentes versions et finitions, les lampes *Nautilus* répondent à d'innombrables besoins d'éclairage, des plus fonctionnels à ceux particulièrement décoratifs, aussi bien dans le domaine résidentiel que professionnel. ●FR

Entschlossenes Design und Spitzentechnologie verschmelzen in dieser Leuchtenfamilie miteinander, die sich durch eine konvexe Linse auszeichnet, die LED-Licht dorthin projiziert, wo es benötigt wird oder am besten gefällt, um ein effizientes und individuelles Ergebnis zu erzielen. Vielseitig und dynamisch, an der Wand oder Decke, in verschiedenen Versionen und Ausführungen, erfüllen die *Nautilus* Leuchten unzählige Beleuchtungsbedürfnisse von den funktionalsten bis hin zu den besonders dekorativen, sowohl im privaten als auch im professionellen Bereich. ●DE

El diseño decidido y la tecnología punta se fusionan en esta familia de lámparas caracterizadas por una lente convexa que proyecta la luz LED donde se necesita o donde más gusta, para un resultado eficiente y personalizado. Versátiles y dinámicas, de pared o de techo, en diferentes versiones y acabados, las lámparas *Nautilus* satisfacen innumerables necesidades de iluminación, de las más funcionales a las más decorativas, tanto en ámbito residencial como profesional. ●ES

Чистый дизайн и передовые технологии сочетаются в этом семействе светильников, характеризующихся выпуклой линзой, которая проецирует свет лампы LED туда, где это необходимо или где вам больше нравится, обеспечивая эффективность и персонализацию. Светильники *Nautilus*, универсальные и динамичные, настенные или потолочные, в разных вариантах исполнения и отделки, удовлетворяют бесчисленные потребности светового оформления, от самого функционального до особо декоративного, как в жилых, так и в профессиональных помещениях. ●RU

决定性的设计与最先进的技术相结合，凸透镜是该系列灯具的特征，该凸透镜可将LED光投射到需要的地方或是您最喜欢的地方，以提高效率和定制化。*Nautilus*灯具具有多功能性和动态性，可以壁式安装或吸顶安装，具有不同的版本和颜色，可以满足无数的照明需求，从最实用的功能到特别装饰性的功能，无论是在住宅还是在专业环境中。●ZH

Nautilus » Wall lamp



Nautilus Mini » Wall lamp

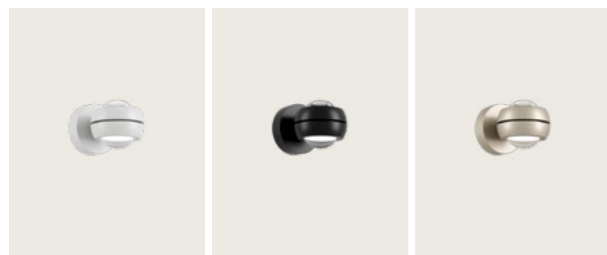

Nautilus » Ceiling lamp

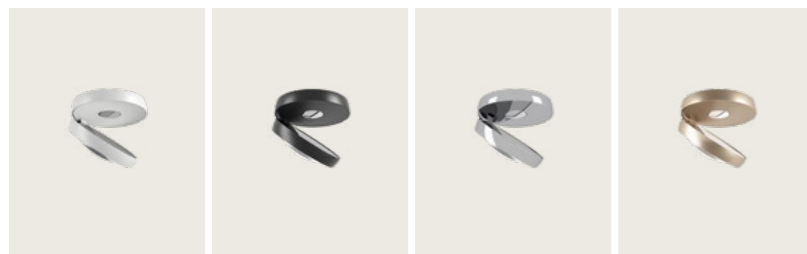

Nautilus Spot » Ceiling lamp



CATEGORY WALL LAMP

Nautilus

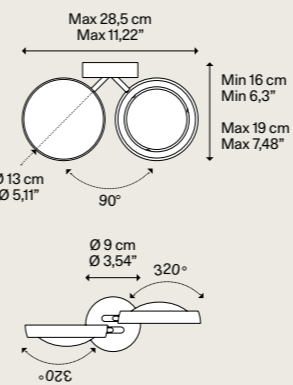

DESIGN Andrea Tosetto, 2017

Metal structure
Montatura in metallo

- Matte White - 9010
Bianco Opaco - 9010
- Matte Black - 9005
Nero Opaco - 9005
- Chrome
Cromo
- Matte Champagne
Champagne Opaco

Code
Codice

- 16550 1930U
- 16550 2930U
- 16550 4030U
- 16550 4930U

Light source
Sorgente luminosa

- AC LED
- 3000 K
- 30 W
- 2310 lm
- 120 V
- CRI 90
- MacAdam 3-Step

LED included
LED incluso

Net weight 1,15 kg / Peso netto 2,54 lbs | Boxes 1 / Colli 1 | Mounts directly to a 4" Standard J-Box - Plate Adaptor included *

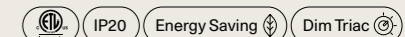

Adjustable light
Luce orientabile

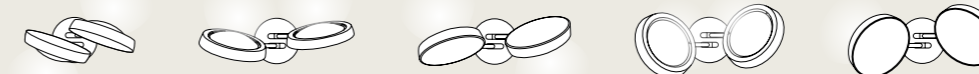

► LED sources with direct power supply to the AC line voltage - driver not required. Dimmable with phase cut dimmer. ► * Recessed backplate available upon request.

► LED con alimentazione diretta a tensione di rete - non necessita di driver. Dimmerabile con varialuce a taglio di fase. ► * Recessed backplate disponibile su richiesta.

CATEGORY WALL LAMP

Nautilus Mini

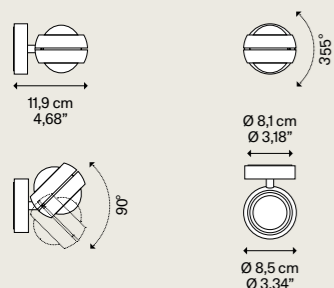

DESIGN Andrea Tosetto, 2017

Metal structure Montatura in metallo	Code Codice
Matte White – 9010 Bianco Opaco – 9010	16552 1030U
Matte Black – 9005 Nero Opaco – 9005	16552 2030U
Matte Champagne Champagne Opaco	16552 4530U

Light source
Sorgente luminosa

LED
3000 K
12 W
840 lm
120 V
CRI 90
MacAdam 3-Step

LED included
LED incluso

Net weight 0,75 kg / Peso netto 1,65 lbs | Boxes Colli 1 | Mounts directly to a 4" Standard J-Box – Plate Adaptor included*

IP20 | Energy Saving | Dim Triac

Adjustable light
Luce orientabile



CATEGORY CEILING LAMP

Nautilus

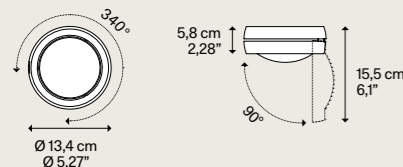

DESIGN Andrea Tosetto, 2017

Metal structure Montatura in metallo	Code Codice
Matte White – 9010 Bianco Opaco – 9010	16530 1030U
Matte Black – 9005 Nero Opaco – 9005	16530 2030U
Chrome Cromo	16530 4030U
Matte Champagne Champagne Opaco	16530 4530U

Light source
Sorgente luminosa

LED
3000 K
15 W
1155 lm
120 V
CRI 90
MacAdam 3-Step

LED included
LED incluso

Net weight 1,10 kg / Peso netto 2,43 lbs | Boxes Colli 1 | Mounts directly to a 4" Standard J-Box

IP20 | Energy Saving | Dim Triac

Adjustable light
Luce orientabile



► LED sources with direct power supply to the AC line voltage – driver not required. Dimmable with phase cut dimmer. ► * Recessed backplate available upon request.

► LED con alimentazione diretta a tensione di rete – non necessita di driver. Dimmerabile con varialuce a taglio di fase. ► * Recessed backplate disponibile su richiesta.

CATEGORY CEILING LAMP

Nautilus Spot

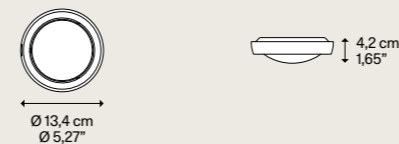

DESIGN Andrea Tosetto, 2020

Metal structure Montatura in metallo	Code Codice
Matte White – 9010 Bianco Opaco – 9010	16560 1030U
Matte Black – 9005 Nero Opaco – 9005	16560 2030U
Chrome Cromo	16560 4030U
Matte Champagne Champagne Opaco	16560 4530U

Light source
Sorgente luminosa

LED
3000 K
10 W
850 lm
120 V
CRI 90
MacAdam 3-Step

LED included
LED incluso

Net weight 0,56 kg / Peso netto 1,23 lbs | Boxes Colli 1 | Mounts directly to a 4" Standard J-Box

IP20 | Energy Saving | Dim Triac

► LED sources with direct power supply to the AC line voltage – driver not required. Dimmable with phase cut dimmer.

► LED con alimentazione diretta a tensione di rete – non necessita di driver. Dimmerabile con varialuce a taglio di fase.

Aile, design by Luca Nichetto, 2021

The *Aile* aluminium wall lamp features a simple and dynamic design reminiscing the aileron of sport cars, after which it has been named. *Aile's* compact size, sleek design, powerful light output with respect to its dimensions and two finishes offer a complete lighting solution even for more intimate settings.

● Spec sheet p. 317

Aile, lampada da parete in alluminio, presenta un design semplice e dinamico, proprio come l'alettone delle auto sportive, aileron in inglese, da cui prende il nome. La compattezza, il design elegante, la forte capacità di emissione di luce rispetto alle dimensioni e le due finiture rendono *Aile* una soluzione perfetta anche per illuminare ambienti raccolti.



AILE	CATEGORY LAMP		TYPE OF LIGHT	
	Wall	Parete	Symmetrical diffused light	Luce simmetrica diffusa

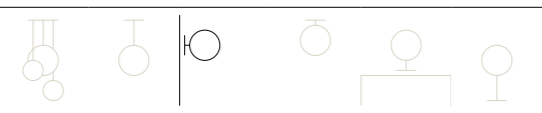



1



2



3

Légère applique en aluminium, *Aile* présente un design simple et dynamique rappelant l'aileron d'une voiture de sport dont le nom s'inspire. La taille compacte d'*Aile*, son design élégant, son rayonnement lumineux puissant par rapport aux dimensions et ses deux finitions offrent une solution d'éclairage complète, même pour des espaces plus intimes. ● FR

Die *Aile* Aluminium-Wandleuchte zeichnet sich durch ein schlichtes und dynamisches Design aus, das an das Querruder eines Sportwagens erinnert – aileron auf Englisch, nach dem sie benannt wurde. Die Kompaktheit, das elegante Design und die starke Lichtleistung im Vergleich zu ihrer Größe sowie die zwei Ausführungen machen *Aile* zu einer perfekten Beleuchtungslösung sogar für intimere Umgebungen. ● DE

Aile, lámpara de pared de aluminio, presenta un diseño sencillo y dinámico, igual que el alerón de los coches deportivos, aileron en inglés, del que toma su nombre. El tamaño compacto, el diseño elegante, la potente emisión de luz con respecto a su tamaño y los dos acabados, hacen que *Aile* sea una solución perfecta incluso para iluminar entornos íntimos. ● ES

Новая настенная алюминиевая лампа *Aile* отличается простым дизайном и динамичной формой, напоминающей элероны спортивных автомобилей, «aileron» на английском, в честь которых она и получила свое название. Компактный размер, элегантный дизайн, мощная светоотдача, по сравнению с ее размерами, а также четыре варианта богатой отделки делают из *Aile* идеальное решение также для освещения более интимных уголков. ● RU

Aile 铝制壁灯拥有简约大方且与动感十足的设计，令人联想至跑车的副翼，从而以此得名。*Aile* 紧凑的尺寸、时尚的设计、相对其尺寸的强大光线输出以及两款饰面，为更多甚为私密的环境设置提供了一项完整的照明解决方案。● ZH

CATEGORY WALL LAMP

Aile

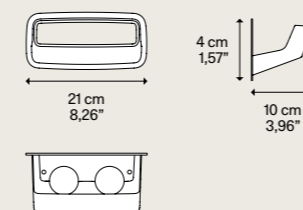

DESIGN Luca Nichetto, 2021

Metal structure
Montatura in metallo

Matte White – 9010
Bianco Opaco – 9010

Matte Champagne
Champagne Opaco

Code
Codice

17550 1030U

17550 4530U

Light source
Sorgente luminosa

LED
3000 K
18 W
1700 lm
120 V
CRI 92
MacAdam 3-Step

LED included
LED incluso

Net weight 0,55 kg
Peso netto 1,21 lbs

Boxes 1
Colli 1

Mounts directly to a 4" Standard J-Box – Plate Adaptor included *

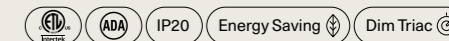

Aile ▾ Wall lamp

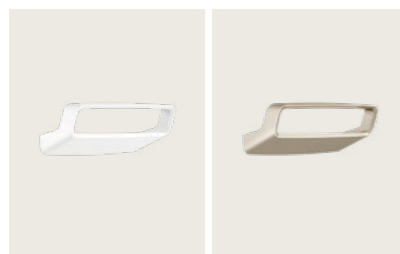

► LED sources with direct power supply to the AC line voltage – driver not required. Dimmable with phase cut dimmer. ► * Recessed backplate available upon request.

► LED con alimentazione diretta a tensione di rete – non necessita di driver. Dimmerabile con varialuce a taglio di fase. ► * Recessed backplate available upon request.

Puzzle Round, *design by* Studio Italia Design, 2016

With its soft shapes, flexible joints and LED light source, *Puzzle Round* can be adjusted at will to create striking light effects on walls and ceilings. The unobtrusive aesthetics and the four available finishes, now including Champagne, make it perfect for the most varied living contexts.

● Spec sheet p. 327

Con le sue forme morbide, i giunti flessibili e la sorgente luminosa a LED, *Puzzle Round* può essere regolata a piacimento per creare suggestivi giochi di luce su pareti e soffitti. L'estetica discreta e le quattro finiture disponibili, ora anche Champagne, la rendono perfetta per i più svariati contesti abitativi.



PUZZLE ROUND	CATEGORY LAMP		TYPE OF LIGHT	
	Wall Ceiling	Parete Soffitto	Diffused light Indirect light Adjustable	Luce diffusa Luce indiretta Orientabile







Avec ses formes souples, les joints flexibles et la source lumineuse à LED, *Puzzle Round* peut être réglée à discrétion pour créer des jeux de lumière suggestifs sur les murs et les plafonds. Son esthétique discrète et les quatre finitions disponibles, y compris le Champagne, la rendent parfaite pour des contextes de vie variés. ● FR

Durch ihre weichen Formen, die flexiblen Gelenke und die LED-Lichtquelle kann *Puzzle Round* nach Belieben eingestellt werden, um wunderbare Lichtspiele an Wänden und Decken entstehen zu lassen. Die unauffällige Ästhetik und die vier verfügbaren Ausführungen - jetzt auch Champagner - machen die Leuchte perfekt für verschiedene Wohnbereiche. ● DE

Con sus formas suaves, articulaciones flexibles y fuente de luz LED, *Puzzle Round* puede ajustarse a voluntad para crear sorprendentes efectos de luz en paredes y techos. La estética discreta y los cuatro acabados disponibles, ahora incluyendo Champán, lo hacen perfecto para una amplia variedad de entornos. ● ES

Благодаря своим мягким формам, гибким соединительным элементам и источнику света LED, светильник *Puzzle Round* можно регулировать по желанию для создания эффектной игры света на стенах и потолках. Неброский дизайн и четыре доступных варианта отделки, теперь включающие Champagne, делают его идеальным для разных жилых контекстов. ● RU

柔软的外形，灵活的接头和LED光源，*Puzzle Round* 可以根据需要进行调整，以在墙壁和天花板上营造出光线的暗示性。谨慎的美学设计以及如今包含香槟色在内的四种可用颜色，使其非常适合各种房屋环境。● ZH

Puzzle Round single ▾ Wall lamp

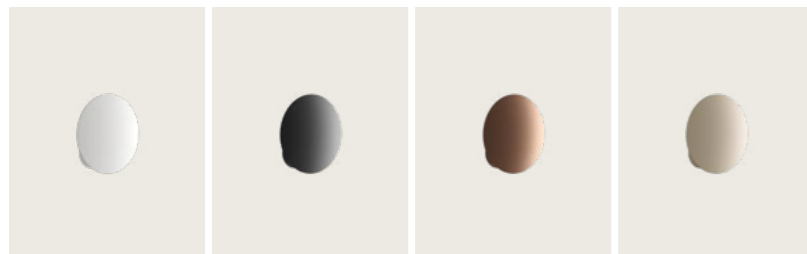

Puzzle Round single ▾ Ceiling lamp



Puzzle Round double ▾ Wall lamp

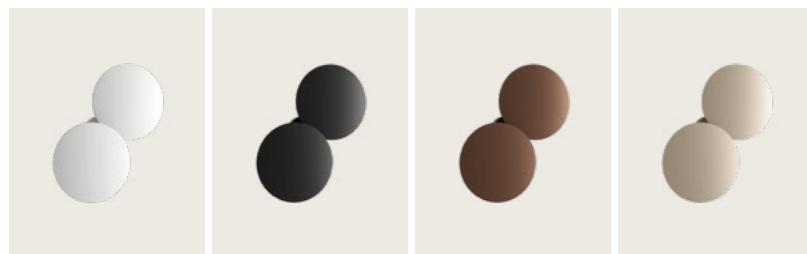

Puzzle Round double ▾ Ceiling lamp



CATEGORY WALL LAMP CEILING LAMP

Puzzle Round single

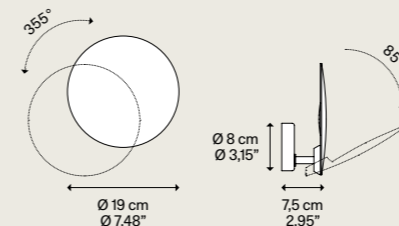

DESIGN Studio Italia Design, 2016

Metal structure
Montatura in metallo

- Matte White - 9016
Bianco Opaco - 9016
- Matte Black - 9005
Nero Opaco - 9005
- Coppery Bronze
Bronzo Ramato
- Champagne
Champagne

Code
Codice

- 15941 1030U
- 15941 2030U
- 15941 3530U
- 15941 4530U

Light source
Sorgente luminosa

LED
3000 K
17 W
1800 lm
120 V
CRI 92
MacAdam 3-Step

LED included
LED incluso

Net weight 0,60 kg / 1,32 lbs | Boxes Colli 1 | Mounts directly to a 4" Standard J-Box - Plate Adaptor included *

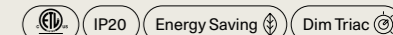

Adjustable light
Luce orientabile



Puzzle Round double

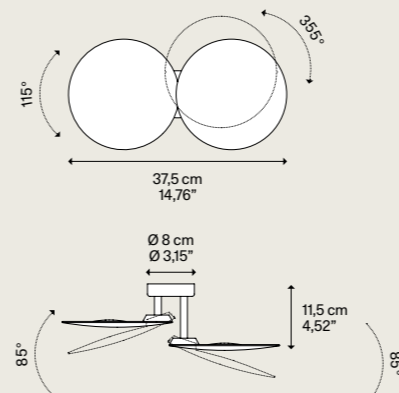

Metal structure
Montatura in metallo

- Matte White - 9016
Bianco Opaco - 9016
- Matte Black - 9005
Nero Opaco - 9005
- Coppery Bronze
Bronzo Ramato
- Champagne
Champagne

Code
Codice

- 15942 1030U
- 15942 2030U
- 15942 3530U
- 15942 4530U

Light source
Sorgente luminosa

LED
3000 K
34 W
3600 lm
120 V
CRI 92
MacAdam 3-Step

LED included
LED incluso

Net weight 1,10 kg / 2,43 lbs | Boxes Colli 1 | Mounts directly to a 4" Standard J-Box - Plate Adaptor included *

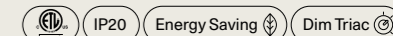

Adjustable light
Luce orientabile



► LED sources with direct power supply to the AC line voltage - driver not required. Dimmable with phase cut dimmer. ► Recessed backplate available upon request.

► LED con alimentazione diretta a tensione di rete - non necessita di driver. Dimmerabile con varialuce a taglio di fase. ► Recessed backplate disponibile su richiesta.



Puzzle, *design by* Studio Italia Design, 2014

Essential forms in metal, square and rectangular, which seem to disappear in the ceiling or wall. Clear-cut geometries that create suggestive plays of light on walls and ceilings, making for a truly personalised atmosphere. With *Puzzle* lamps, light becomes the feature element of living spaces, creating soft, geometric effects.

● Spec sheet p. 333

Forme essenziali in metallo, quadrati e rettangoli che sembrano scomparire nel soffitto o nella parete. Geometria rigorose che possono essere regolate a piacimento per creare suggestivi giochi di luce su pareti e soffitti, rendendo l'atmosfera del tutto personale. Le lampade *Puzzle* rendono la luce il vero ornamento degli ambienti abitativi creando effetti di morbide geometrie.

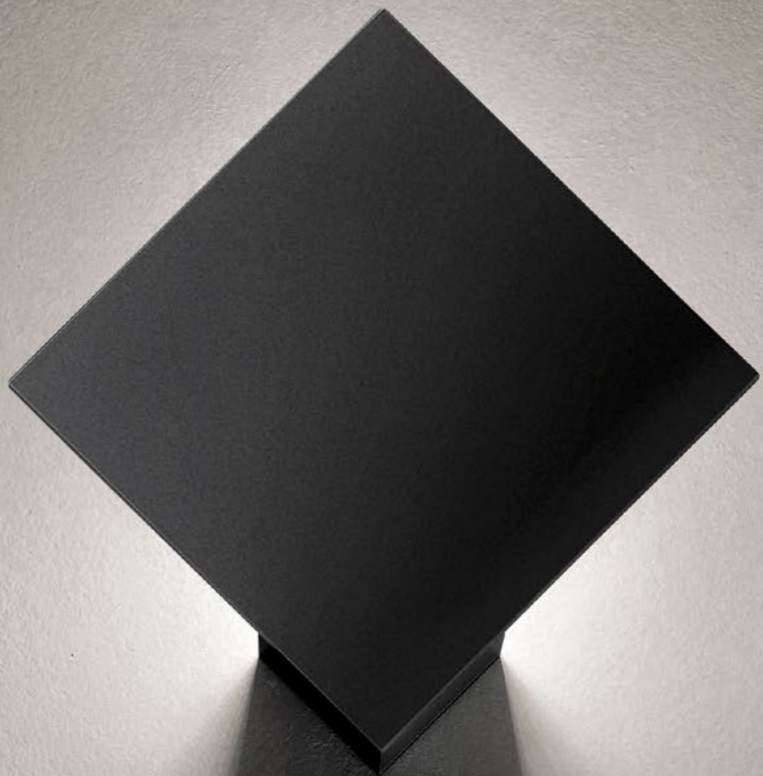

PUZZLE	CATEGORY LAMP		TYPE OF LIGHT	
	Wall Ceiling	Parete Soffitto	Diffused light Indirect light	Luce diffusa Luce indiretta

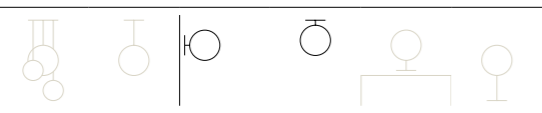



1



2



3

- 1 Puzzle single square, FINISH Matte Black.
- 2 Puzzle square & rectangle, FINISH Matte White.
- 3 Puzzle double square, FINISH Matte Black.

Formes essentielles en métal, carrées et rectangulaires qui semblent disparaître dans le plafond ou le mur. Des géométries rigoureuses qui créent des jeux de lumières suggestifs sur les murs et plafonds pour créer une atmosphère personnelle. Les lampes *Puzzle* font de la lumière une décoration des espaces de vie et créent des effets géométriques harmonieux. ●FR

Einfache Formen aus Metall, quadratisch und rechteckig, die in der Decke oder in der Wand zu verschwinden scheinen. Klare Geometrien, die an Wänden und Decken wunderbare Lichtspiele erzeugen, um die Atmosphäre vollkommen persönlich zu gestalten. Die Leuchten *Puzzle* machen das Licht zum wahren Ornament von Wohnräumen und lassen Effekte mit weicher geometrischer Form entstehen. ●DE

Formas esenciales de metal, cuadrados y rectángulos que parecen desaparecer en el techo o la pared. Rigurosas geometrías que crean sugestivos efectos de luz en paredes y techos haciendo que la atmósfera sea completamente personal. Las lámparas *Puzzle* hacen que la luz sea el verdadero ornamento de los espacios habitables, creando efectos de geometrías suaves. ●ES

Простые формы из металла, квадраты и прямоугольники, которые как бы исчезают в потолке или стене. Строгие геометрические формы, которые можно отрегулировать по своему вкусу, создавая живописную игру света на стенах и потолках и полностью персонализируя атмосферу. Светильники *Puzzle* превращают свет в истинный декоративный элемент жилых интерьеров, создавая мягкие геометрические эффекты. ●RU

基本的金属形状，是似乎在吸顶灯和壁灯中消失的正方形和矩形。严格的几何形状可以随意调节，在墙壁和天花板上营造出暗示性的光线，使氛围完全个性化。*Puzzle*灯通过创造柔和的几何效果，使照明成为生活空间的真正装饰品。●ZH

Puzzle single square ▾ Wall lamp

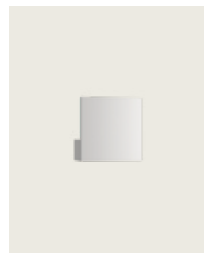

Puzzle single square ▾ Ceiling lamp

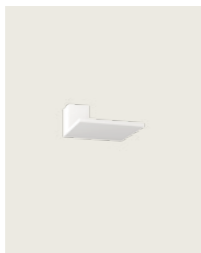

Puzzle double square ▾ Wall lamp



Puzzle double square ▾ Ceiling lamp



Puzzle square & rectangle ▾ Wall lamp

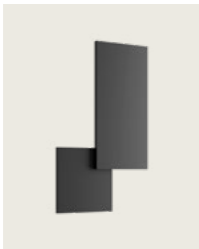

Puzzle square & rectangle ▾ Ceiling lamp



CATEGORY WALL LAMP CEILING LAMP

Puzzle single square

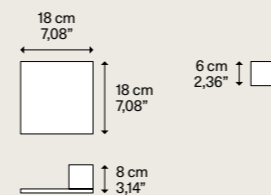

DESIGN Studio Italia Design, 2014

Metal structure
Montatura in metallo

- Matte White - 9016
Bianco Opaco - 9016
- Matte Black - 9005
Nero Opaco - 9005

Code
Codice

14641 1030U

14641 2030U

Light source
Sorgente luminosa

- LED 3000 K
- 17 W
- 1800 lm
- 120 V
- CRI 92
- MacAdam 3-Step

LED included
LED incluso

Net weight 1,16 kg
Peso netto 2,56 lbs

Boxes Colli 1

Mounts directly to a 4" Standard J-Box - Plate Adaptor included *

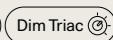
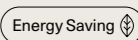

Puzzle double square

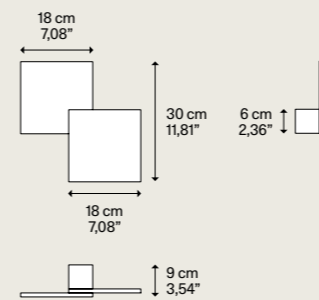

Metal structure
Montatura in metallo

- Matte White - 9016
Bianco Opaco - 9016
- Matte Black - 9005
Nero Opaco - 9005

Code
Codice

14642 1030U

14642 2030U

Light source
Sorgente luminosa

- LED 3000 K
- 34 W
- 3600 lm
- 120 V
- CRI 92
- MacAdam 3-Step

LED included
LED incluso

Net weight 2,00 kg
Peso netto 4,41 lbs

Boxes Colli 1

Mounts directly to a 4" Standard J-Box - Plate Adaptor included *

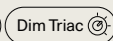
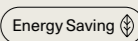

Puzzle square & rectangle

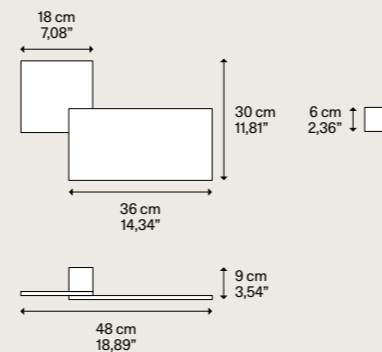

Metal structure
Montatura in metallo

- Matte White - 9016
Bianco Opaco - 9016
- Matte Black - 9005
Nero Opaco - 9005

Code
Codice

14643 1030U

14643 2030U

Light source
Sorgente luminosa

- LED 3000 K
- 34 W
- 3600 lm
- 120 V
- CRI 92
- MacAdam 3-Step

LED included
LED incluso

Net weight 2,91 kg
Peso netto 6,42 lbs

Boxes Colli 1

Mounts directly to a 4" Standard J-Box - Plate Adaptor included *

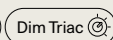
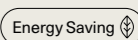

► LED sources with direct power supply to the AC line voltage - driver not required. Dimmable with phase cut dimmer. ► Optional backplate available. ► Recessed backplate available upon request.

► LED con alimentazione diretta a tensione di rete - non necessita di driver. Dimmerabile con varialuce a taglio di fase. ► Disponibile piastra a muro opzionale. ► Recessed backplate disponibile su richiesta.

Puzzle Mega, design by Studio Italia Design, 2019

Large geometric figures characterised by essential forms, which almost merge with the interior architecture when off, only to be surprisingly revealed as harmonies of light and shadow when lit. New matte finishes warm up the geometric panels of *Puzzle Mega*. Liquid paints that open new decorative possibilities, playing with harmonies and contrasts of colours and shapes.

● Spec sheet p. 345

Grandi figure geometriche dalle forme essenziali che quasi si fondono con l'architettura interna quando sono spente, per rivelare inaspettate armonie di luci e ombre una volta accese. Nuove finiture opache scaldano i pannelli geometrici di *Puzzle Mega*. Vernici liquide che aprono nuove possibilità decorative giocando con armonie e contrasti di colori e forme.

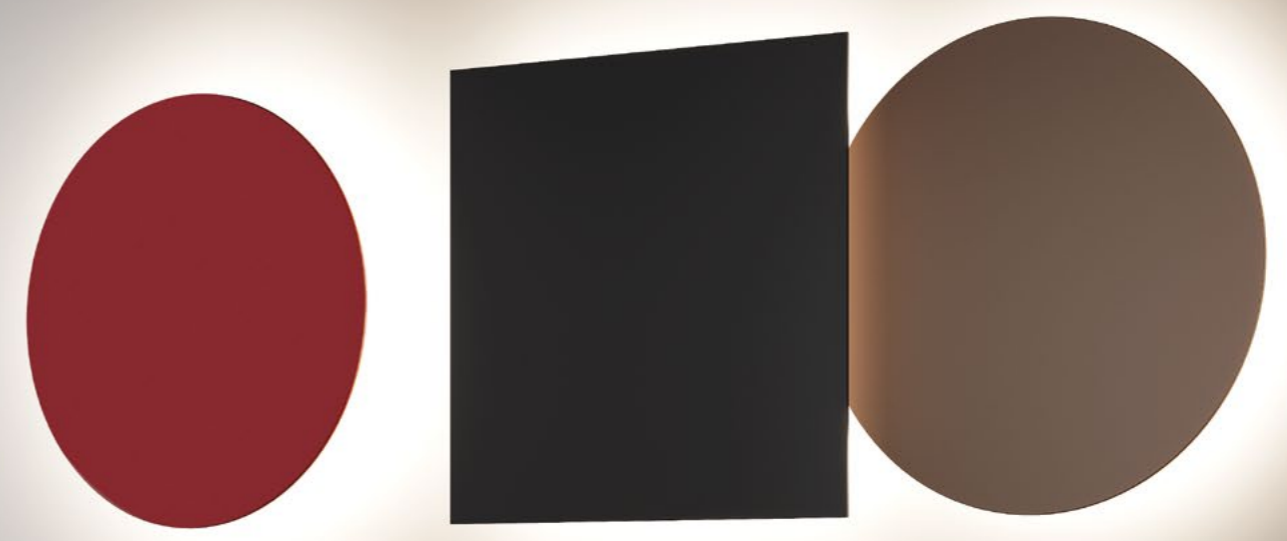

PUZZLE MEGA	CATEGORY LAMP		TYPE OF LIGHT	
	Wall Ceiling	Parete Soffitto	Diffused light Indirect light	Luce diffusa Luce indiretta

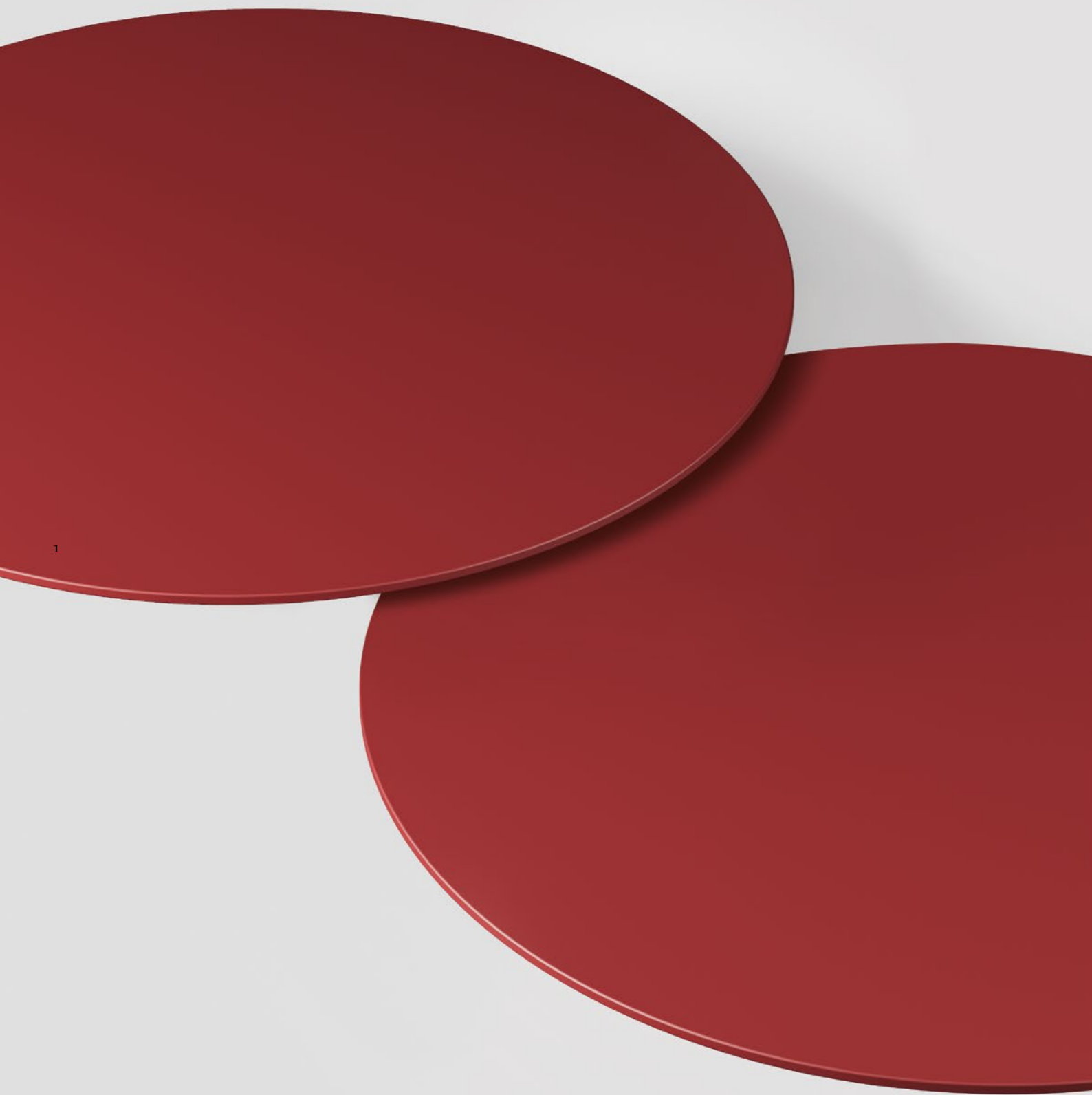

1

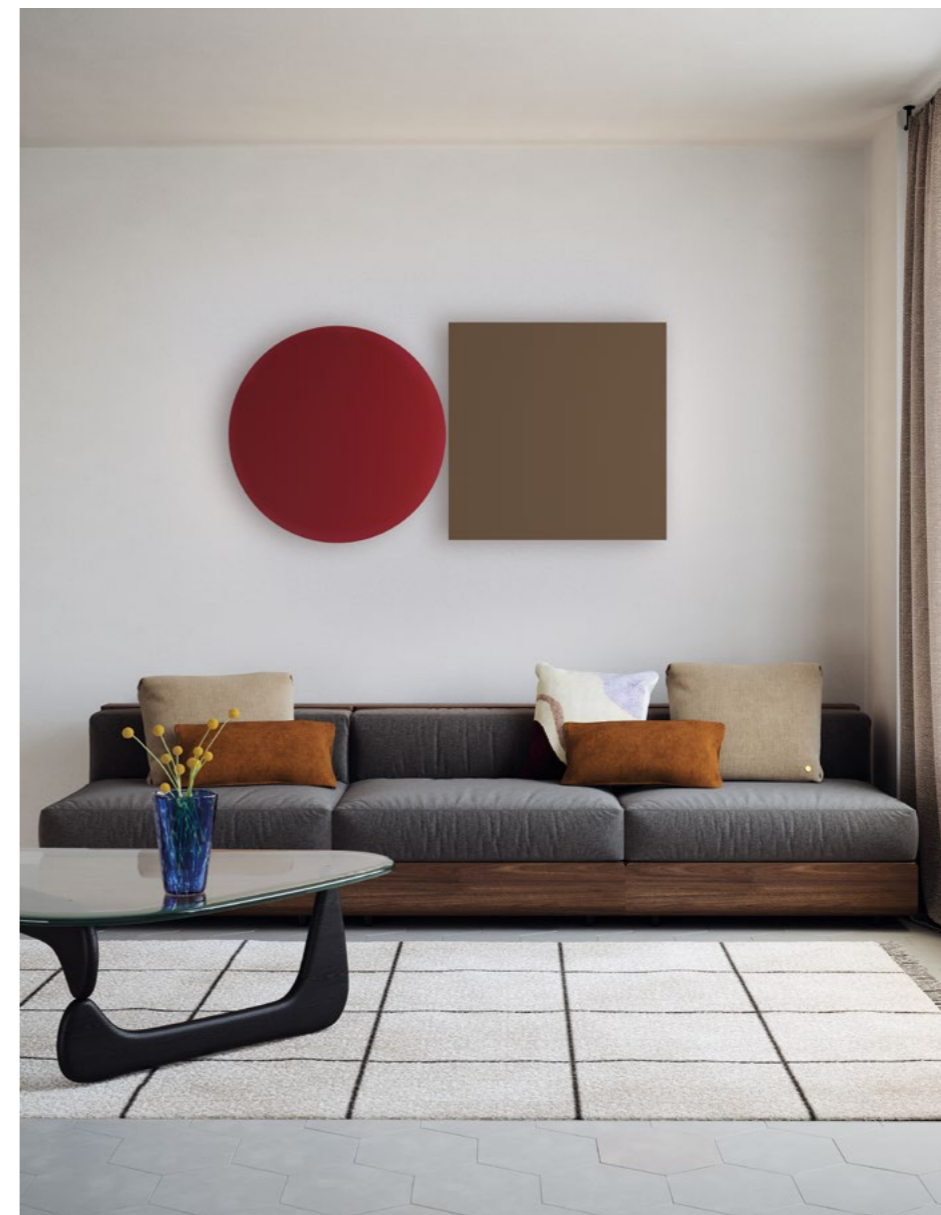

2

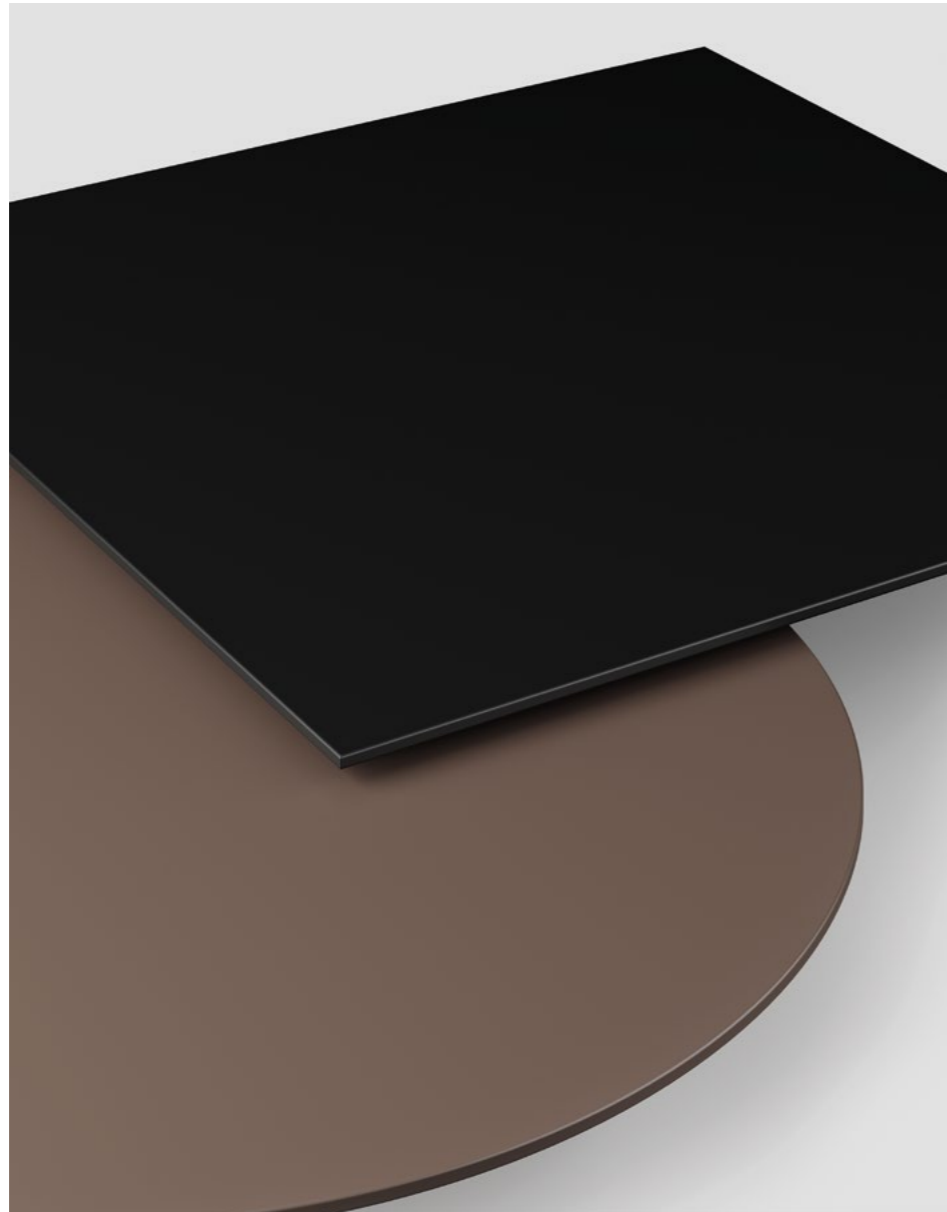

1



2

1 Puzzle Mega square and round, FINISHES Matte Black and Taupe.
 2 Puzzle Mega square and round, FINISHES Matte Black and White.





Grandes figures géométriques aux formes essentielles qui se fondent presque dans l'architecture interne lorsqu'elles sont éteintes, pour révéler d'inattendues harmonies de lumière et d'ombres une fois éclairées. Les nouvelles finitions mates rendent les panneaux géométriques de *Puzzle Mega* plus chaleureux. Vernis liquides qui offrent de nouvelles possibilités décoratives en jouant avec les harmonies et les contrastes de couleurs et de formes. ● FR

Große geometrische Figuren in einfacher Form, die ausgeschaltet mit der Innenarchitektur verschmelzen, um eingeschaltet eine unerwartete Harmonie aus Licht und Schatten entstehen zu lassen. Neue matte Ausführungen erwärmen die geometrischen Paneele von *Puzzle Mega*. Flüssiglacke, die durch das Spiel mit Harmonien und Kontrasten von Farben und Formen neue dekorative Möglichkeiten eröffnen. ● DE

Grandes figuras geométricas con formas esenciales que casi se mezclan con la arquitectura interior cuando se apagan, para revelar inesperadas armonías de luz y sombras una vez encendidas. Nuevos acabados mate calientan los paneles geométricos de *Puzzle Mega*. Pinturas líquidas que brindan nuevas posibilidades decorativas jugando con armonías y contrastes de colores y formas. ● ES

Крупные геометрические фигуры с простыми строгими формами, которые почти полностью сливаются с архитектурой интерьера, когда они выключены. Но стоит их включить, как вы увидите неожиданную и гармоничную игру света и тени. Новые матовые отделки согревают геометрические панели *Puzzle Mega*. Жидкие эмали, открывающие новые декоративные возможности, играя с гармонией и контрастами цветов и форм. ● RU

该灯具具有大型几何图形的基本形状，关闭时，几乎与内部架构融为一体，一旦打开，会发现意想不到的光影和谐。全新哑光饰面为 *Puzzle Mega* 的几何面板带来温暖。液体涂料通过色彩和形状的和谐与对比开辟了新的装饰可能性。● ZH

Puzzle Mega round small ▾ Wall lamp

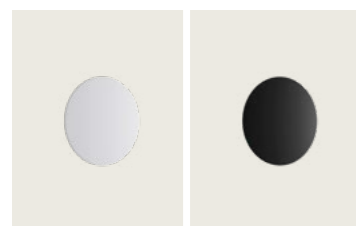

Puzzle Mega round large ▾ Wall lamp

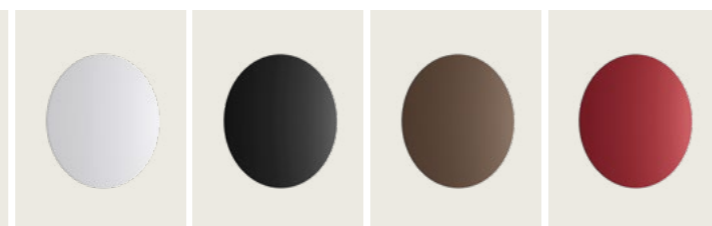

Puzzle Mega round small ▾ Ceiling lamp



Puzzle Mega round large ▾ Ceiling lamp



Puzzle Mega square small ▾ Wall lamp

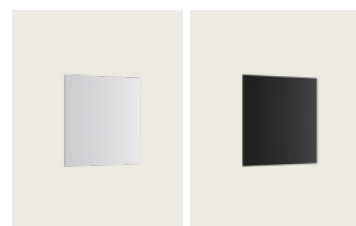

Puzzle Mega square large ▾ Wall lamp

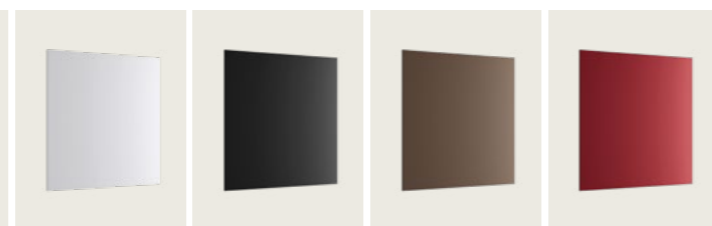

Puzzle Mega square small ▾ Ceiling lamp

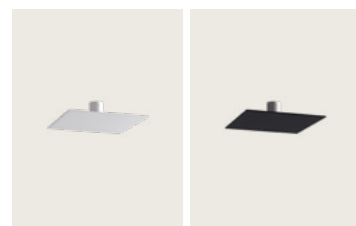

Puzzle Mega square large ▾ Ceiling lamp

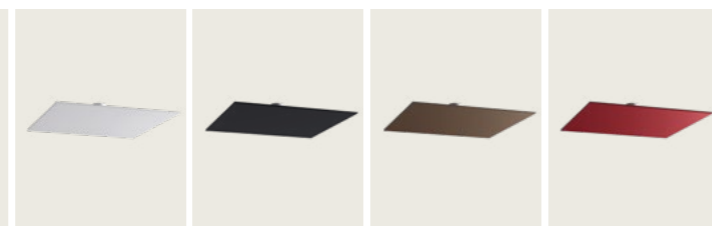

CATEGORY WALL LAMP CEILING LAMP

Puzzle Mega round small

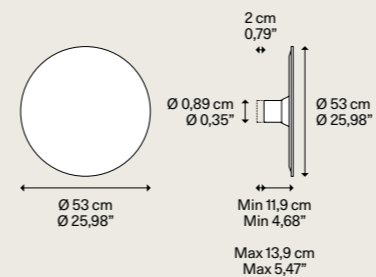

DESIGN Studio Italia Design, 2019

Metal structure
Montatura in metallo

Matte White - 9016
Bianco Opaco - 9016

Light source
Sorgente luminosa

LED
3000 K
51 W
5400 lm
120 V
CRI 92
MacAdam 3-Step

LED included
LED incluso

MDF diffuser
Diffusore in MDF

Matte White - 9016
Bianco Opaco - 9016

Matte Black - 9005
Nero Opaco - 9005

Taupe
Grigio Caldo

Red
Rosso

Code
Codice

16741 1030U

16741 2030U

16741 3930U

16741 6030U

Net weight 3,80 kg
Peso netto 8,38 lbs
Boxes 2
Colli 2
Mounts directly to a 4" Standard J-Box - Plate Adaptor included *

IP20 Energy Saving Dim Triac

Puzzle Mega round large

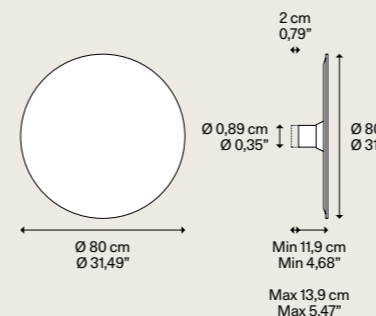

Metal structure
Montatura in metallo

Matte White - 9016
Bianco Opaco - 9016

Light source
Sorgente luminosa

LED
3000 K
68 W
7200 lm
120 V
CRI 92
MacAdam 3-Step

LED included
LED incluso

MDF diffuser
Diffusore in MDF

Matte White - 9016
Bianco Opaco - 9016

Matte Black - 9005
Nero Opaco - 9005

Taupe
Grigio Caldo

Red
Rosso

Code
Codice

16744 1030U

16744 2030U

16744 3930U

16744 6030U

Net weight 7,20 kg
Peso netto 15,87 lbs
Boxes 2
Colli 2
Mounts directly to a 4" Standard J-Box - Plate Adaptor included *

IP20 Energy Saving Dim Triac

► LED sources with direct power supply to the AC line voltage - driver not required. Dimmable with phase cut dimmer. ► * Recessed backplate available upon request.

► LED con alimentazione diretta a tensione di rete - non necessita di driver. Dimmerabile con varialuce a taglio di fase. ► * Recessed backplate available upon request.

CATEGORY WALL LAMP CEILING LAMP

DESIGN Studio Italia Design, 2019

Puzzle Mega square small

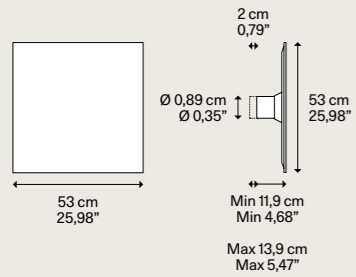

Metal structure
Montatura in metallo

● Matte White - 9016
Bianco Opaco - 9016

Light source
Sorgente luminosa

LED
3000 K
51 W
5400 lm
120 V
CRI 92
MacAdam 3-Step

LED included
LED incluso

MDF diffuser
Diffusore in MDF

● Matte White - 9016
Bianco Opaco - 9016

● Matte Black - 9005
Nero Opaco - 9005

● Taupe
Grigio Caldo

● Red
Rosso

Code
Codice

16742 1030U

16742 2030U

16742 3930U

16742 6030U

Net weight 4,10 kg / Peso netto 9,04 lbs | Boxes Colli 2 | Mounts directly to a 4" Standard J-Box - Plate Adaptor included*

IP20 | Energy Saving | Dim Triac

Puzzle Mega square large

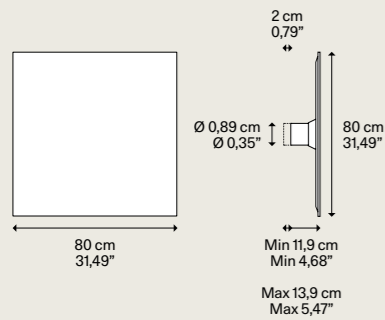

Metal structure
Montatura in metallo

● Matte White - 9016
Bianco Opaco - 9016

Light source
Sorgente luminosa

LED
3000 K
68 W
7200 lm
120 V
CRI 92
MacAdam 3-Step

LED included
LED incluso

MDF diffuser
Diffusore in MDF

● Matte White - 9016
Bianco Opaco - 9016

● Matte Black - 9005
Nero Opaco - 9005

● Taupe
Grigio Caldo

● Red
Rosso

Code
Codice

16745 1030U

16745 2030U

16745 3930U

16745 6030U

Net weight 8,80 kg / Peso netto 19,40 lbs | Boxes Colli 2 | Mounts directly to a 4" Standard J-Box - Plate Adaptor included*

IP20 | Energy Saving | Dim Triac

► LED sources with direct power supply to the AC line voltage - driver not required. Dimmable with phase cut dimmer. ► * Recessed backplate available upon request.

► LED con alimentazione diretta a tensione di rete - non necessita di driver. Dimmerabile con varialuce a taglio di fase. ► * Recessed backplate available upon request.

CATEGORY ACCESSORY

DESIGN Studio Italia Design, 2019

Puzzle Mega extension

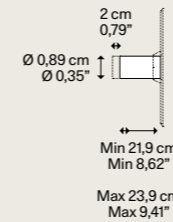

Net weight 0,86 kg / Peso netto 1,86 lbs | Boxes Colli 1

IP20

Description
Descrizione

Extension optional ► to be used to widen the light beam in case of ceiling installation

Estensione opzionale ► da utilizzare per ampliare il fascio luminoso in caso di installazione a soffitto

Metal structure
Montatura in metallo

● Matte White - 9016
Bianco Opaco - 9016

Code
Codice

16799 A200

Puzzle Mega standard version
Puzzle Mega versione standard

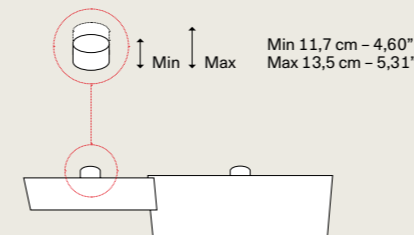

Puzzle Mega extension optional version
Puzzle Mega versione estensione opzionale

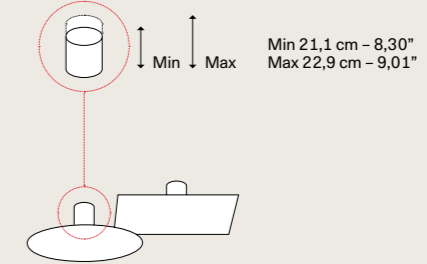

Bugia, design by Andrea Tosetto, 2016/2020

Round, compact forms featuring elegant finishes with a centre that shines like a precious stone. Once lit up, *Bugia* amazes with the unexpected effect of its light. A surprising and harmonious balance between direct and indirect light, diffused both downward and up toward the ceiling. A rich family of ceiling lights, in *Single*, *Double*, *Triple* and *Mega* versions.

● Spec sheet p. 354

Forme rotonde compatte dalle finiture raffinate con un centro che splende come una pietra preziosa. Appena viene accesa, *Bugia* sorprende per l'effetto inaspettato della sua luce. Un inaspettato equilibrio armonico tra luce diretta e indiretta, diffusa sia verso il basso che verso il soffitto. Una ricca famiglia di plafoniere, in versione *Single*, *Double*, *Triple* e *Mega*.



BUGIA	CATEGORY LAMP		TYPE OF LIGHT	
	Ceiling	Soffitto	Symmetrical diffused light	Luce simmetrica diffusa

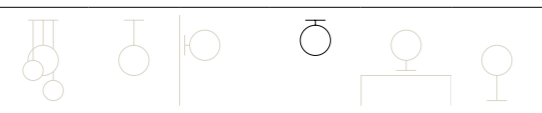





Forme ronde compacte aux finitions raffinées avec un point central qui brille comme une pierre précieuse. Une fois allumée, *Bugia* surprend par l'effet inattendu de sa lumière. Un harmonieux équilibre inattendu entre lumière directe et indirecte, diffusée vers le bas ou vers le plafond. Une riche famille de plafonniers, en version *Single*, *Double*, *Triple* et *Mega*. ●FR

Kompakte, runde Formen mit raffinierten Ausführungen und einem Mittelpunkt, der wie ein Edelstein funkelt. Beim Einschalten überrascht *Bugia* durch den unerwarteten Effekt ihres Lichts. Ein unerwartet harmonisches Gleichgewicht zwischen direktem und indirektem Licht, das sowohl nach unten wie auch zur Decke gestrahlt wird. Eine ganze Familie von Deckenleuchten, in *Single*-, *Double*-, *Triple*- und *Mega*-Versionen. ●DE

Formas redondas compactas con acabados refinados con un centro que brilla como una piedra preciosa. Tan pronto como se enciende, *Bugia* sorprende con el inesperado efecto de su luz. Un inesperado equilibrio armónico entre la luz directa e indirecta, difusa tanto hacia abajo como hacia el techo. Una rica familia de lámparas de techo, en versiones *Single*, *Double*, *Triple* y *Mega*. ●ES

Компактные круглые формы с изысканной отделкой, в центре которых как бы сияет драгоценный камень. Сразу же при включении светильник *Bugia* поражает своим потрясающим световым эффектом. Неожиданно уравновешенная гармония между прямым и непрямым светом, распространяющимся как вниз, так и к потолку. Богатая семья плафонов в вариации *Single*, *Double*, *Triple* и *Mega*. ●RU

*Bugia*圆形灯,紧凑的形状有着优雅的饰面,其中心部分犹如宝石一般闪耀。一经点亮,*Bugia*就会以其意想不到的灯光效果而惊艳众生。直射照明与间接照明之间有着令人惊叹的和谐平衡,向下扩散的同时亦可向上漫射至天花板。它是一款丰富多样的吸顶灯系列,有单灯、双灯、三灯和*Mega*巨型版本。●ZH

Bugia Single ▾ Ceiling lamp

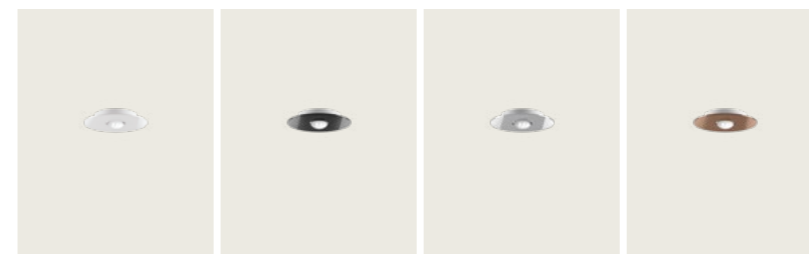

Bugia Double ▾ Ceiling lamp



Bugia Triple ▾ Ceiling lamp



Bugia Mega ▾ Ceiling lamp

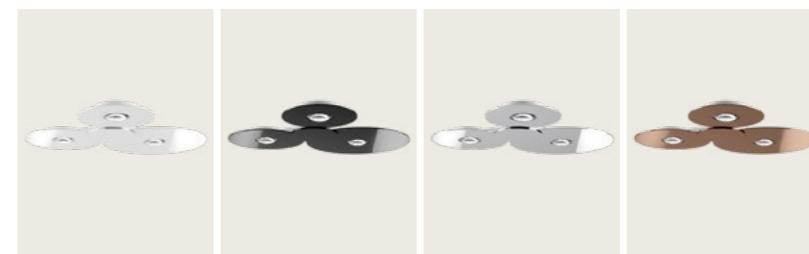

CATEGORY **CEILING LAMP**

DESIGN **Andrea Tosetto, 2016**

Bugia Single

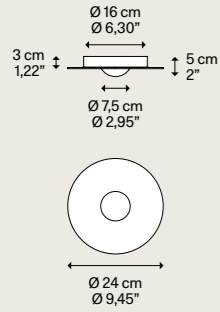

Metal structure
Montatura in metallo

● Matte White - 9010
Bianco Opaco - 9010

Light source
Sorgente luminosa

LED
3000 K
17 W
1800 lm
120 V
CRI 90
MacAdam 3-Step

LED included
LED incluso

Methacrylate diffuser
Diffusore in metacrilato

● Glossy White Bianco Lucido	16131 1230U
● Glossy Black Nero Lucido	16131 2230U
● Chrome Cromo	16131 4030U
● Glossy Bronze Bronzo Lucido	16131 4630U

Code
Codice

Net weight 0,80 kg / Peso netto 1,76 lbs | Boxes Colli 2 | Mounts directly to a 4" Standard J-Box

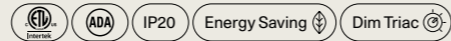

Bugia Double

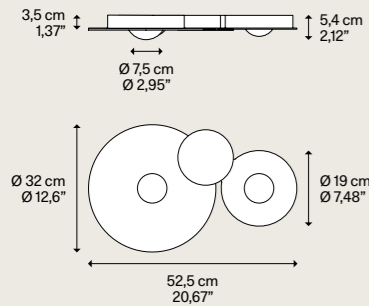

Metal structure
Montatura in metallo

● Matte White - 9010
Bianco Opaco - 9010

Light source
Sorgente luminosa

LED
3000 K
34 W
2600 lm
120 V
CRI 90
MacAdam 3-Step

LED included
LED incluso

Methacrylate diffuser
Diffusore in metacrilato

● Glossy White Bianco Lucido	16132 1230U
● Glossy Black Nero Lucido	16132 2230U
● Chrome Cromo	16132 4030U
● Glossy Bronze Bronzo Lucido	16132 4630U

Code
Codice

Net weight 2,05 kg / Peso netto 4,52 lbs | Boxes Colli 2 | Mounts directly to a 4" Standard J-Box

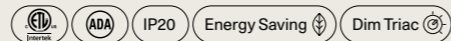

► LED sources with direct power supply to the AC line voltage – driver not required. Dimmable with phase cut dimmer.

► LED con alimentazione diretta a tensione di rete – non necessita di driver. Dimmerabile con varialuce a taglio di fase.

CATEGORY **CEILING LAMP**

DESIGN **Andrea Tosetto, 2016**

Bugia Triple

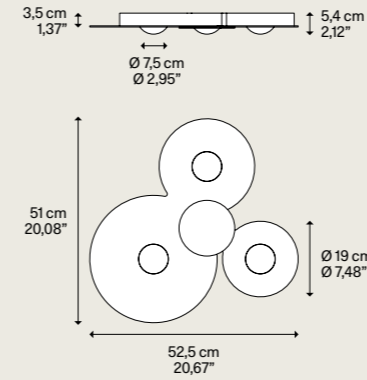

Metal structure
Montatura in metallo

● Matte White - 9010
Bianco Opaco - 9010

Light source
Sorgente luminosa

LED
3000 K
51 W
5400 lm
120 V
CRI 90
MacAdam 3-Step

LED included
LED incluso

Methacrylate diffuser
Diffusore in metacrilato

● Glossy White Bianco Lucido	16133 1230U
● Glossy Black Nero Lucido	16133 2230U
● Chrome Cromo	16133 4030U
● Glossy Bronze Bronzo Lucido	16133 4630U

Code
Codice

Net weight 2,80 kg / Peso netto 6,17 lbs | Boxes Colli 2 | Mounts directly to a 4" Standard J-Box

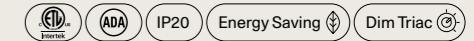

CATEGORY **CEILING LAMP**

DESIGN **Andrea Tosetto, 2020**

Bugia Mega

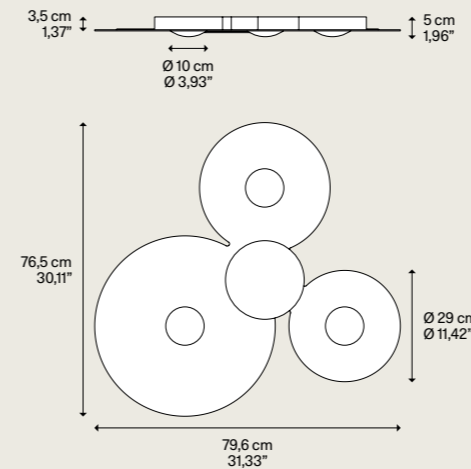

Metal structure
Montatura in metallo

● Matte White - 9010
Bianco Opaco - 9010

Light source
Sorgente luminosa

LED
3000 K
51 W
5400 lm
120 V
CRI 90
MacAdam 3-Step

LED included
LED incluso

Methacrylate diffuser
Diffusore in metacrilato

● Glossy White Bianco Lucido	16134 1230U
● Glossy Black Nero Lucido	16134 2230U
● Chrome Cromo	16134 4030U
● Glossy Bronze Bronzo Lucido	16134 4630U

Code
Codice

Net weight 4,40 kg / Peso netto 9,70 lbs | Boxes Colli 2 | Mounts directly to a 4" Standard J-Box

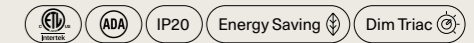

► LED sources with direct power supply to the AC line voltage – driver not required. Dimmable with phase cut dimmer.

► LED con alimentazione diretta a tensione di rete – non necessita di driver. Dimmerabile con varialuce a taglio di fase.

Pin-Up, design by Andrea Tosetto, 2015

A striking, compact light with a simple, organic design, *Pin-Up* opens like a shell to provide a bright light and the quality of LED lighting. A light that can be modelled at will thanks to the flexibility of the light fixture and the availability of two LED sources.

● Spec sheet p. 361

Una lampada compatta e sorprendente, dal design essenziale ed organico, *Pin-Up* si schiude come una conchiglia per illuminare gli spazi con la decisione e la qualità della luce a LED. Una luce che può essere modellata a piacere grazie alla flessibilità della lampada e alla disponibilità di due sorgenti LED.



PIN-UP	CATEGORY LAMP		TYPE OF LIGHT	
	Wall Ceiling	Parete Soffitto	Symmetrical diffused light Adjustable	Luce simmetrica diffusa Orientabile

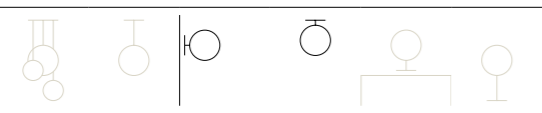



Pin-Up, FINISH Coppery Bronze.



Pin-Up, FINISH Matte White.

Lampe compacte et surprenante, au design essentiel et organique, *Pin-Up* s'ouvre comme une coquille pour éclairer les espaces avec la précision et la qualité de la lumière LED. Une lumière qui peut être modelée à souhait grâce à la flexibilité de la lampe et à la disponibilité de deux sources LED. ●FR

Als eine kompakte und überraschende Lampe mit klarem, organischem Design schließt sich *Pin-Up* wie eine Muschel, um Räume mit der Entschlossenheit und Qualität von LED-Licht zu erhellen. Ein Licht, das dank der Flexibilität der Lampe und des Vorhandenseins von zwei LED-Quellen verändert werden kann. ●DE

Una lámpara compacta y sorprendente, de diseño esencial y orgánico, *Pin-Up* se abre como una concha para iluminar los espacios con la decisión y la calidad de la luz de LED. Una luz que puede ser modelada a gusto gracias a la flexibilidad de la lámpara y a la disponibilidad de dos fuentes de LED. ●ES

Pin-Up - изумительный компактный светильник со сдержанным, органичным дизайном. Открывается как ракушка и смело освещает пространство качественным светодиодным светом. Превосходная гибкость и наличие двух светодиодных источников позволяют моделировать освещение по желанию. ●RU

*Pin-Up*是一款紧凑而令人惊喜的灯具，设计简洁有序，如一个贝壳打开，以坚定而优质的LED灯光照亮空间。灯身灵活，配有两盏LED光源，灯光可随喜好调节。●ZH

CATEGORY WALL LAMP CEILING LAMP

Pin-Up

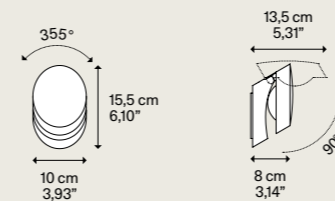

DESIGN Andrea Tosetto, 2015

Metal structure
Montatura in metallo

Matte White - 9010
Bianco Opaco - 9010

Matte Black - 9005
Nero Opaco - 9005

Coppery Bronze
Bronzo Ramato

Code
Codice

15540 1030U

15540 2030U

15540 3530U

Light source
Sorgente luminosa

LED
3000 K
9 W
850 lm
120 V
CRI 92
MacAdam 3-Step

LED included
LED incluso

Net weight 1,15 kg
Peso netto 2,53 lbs

Boxes 1
Colli 1

Mounts directly to a 4" Standard J-Box - Plate Adaptor included *



IP20

Energy Saving

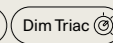

Adjustable light
Luce orientabile



Pin-Up > Wall lamp, Ceiling lamp

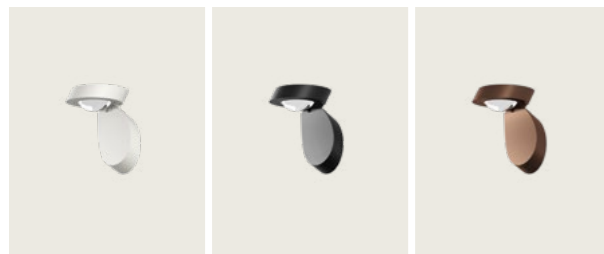

► LED sources with direct power supply to the AC line voltage - driver not required. Dimmable with phase cut dimmer. ► * Recessed backplate available upon request.

► LED con alimentazione diretta a tensione di rete - non necessita di driver. Dimmerabile con varialuce a taglio di fase. ► * Recessed backplate disponibile su richiesta.

Laser, *design by* Studio Italia Design, 2015

Laser is a compact, versatile light fixture in the shape of a box with an attractive architectural look. From its painted steel structure, available in one size and three different finishes, now including Champagne, the LED light source diffuses a functional and evocative two-way light that creates plays of light and shadow on the wall.

● Spec sheet p. 367

Laser è una lampada compatta a forma di parallelepipedo dal carattere versatile e architettonico. Dalla sua struttura in acciaio verniciato, disponibile in una dimensione e in tre diverse finiture, ora anche Champagne, la sorgente a LED diffonde una luce bidirezionale funzionale e d'effetto che crea giochi di luce ed ombra sulla parete.

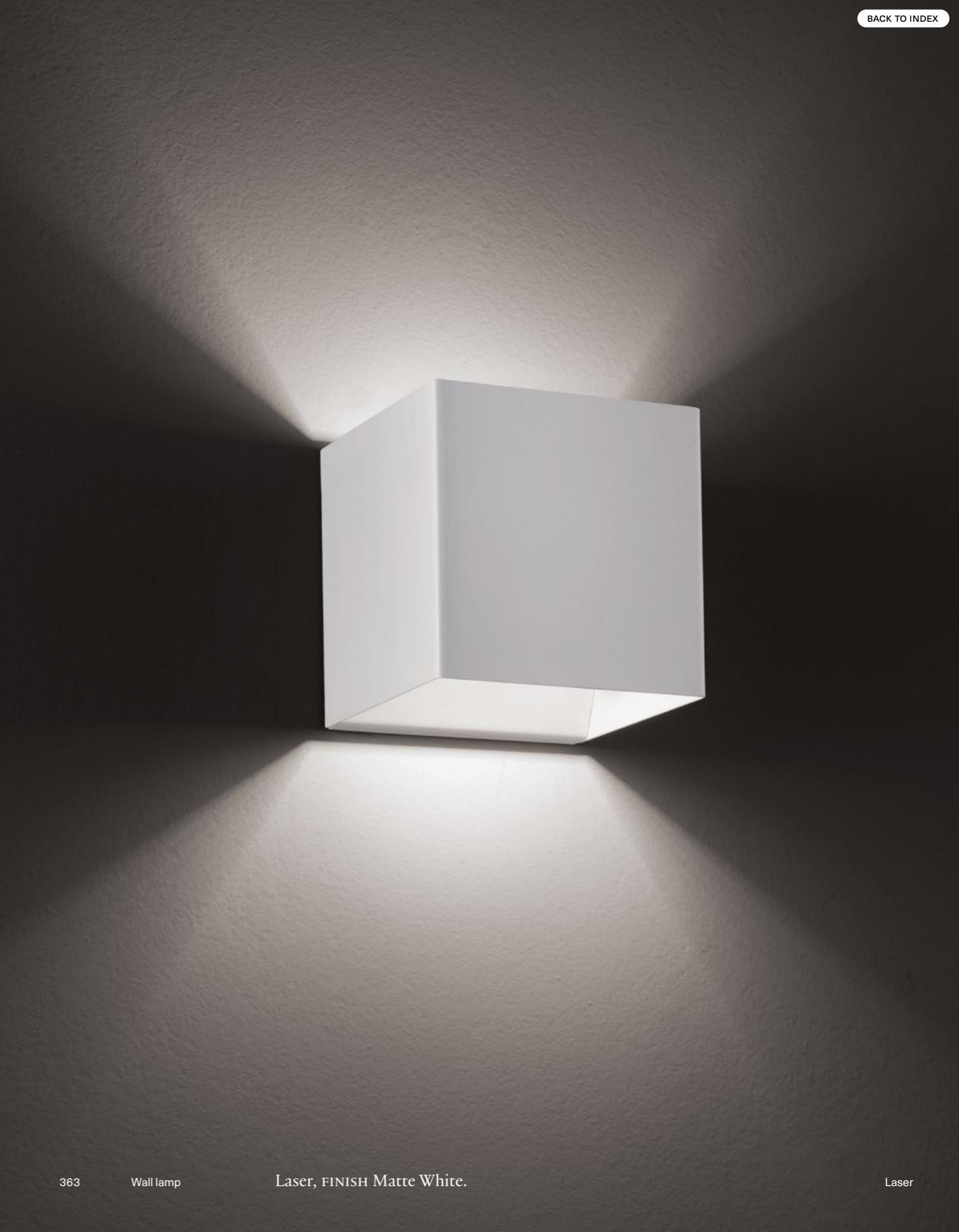

LASER	CATEGORY LAMP		TYPE OF LIGHT	
	Wall	Parete	Symmetrical diffused light	Luce simmetrica diffusa

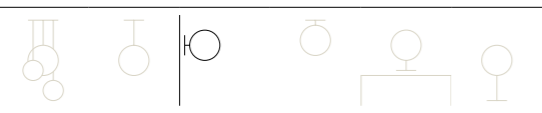



Laser, FINISH Champagne.



Laser, FINISH Matte Black.

Laser est une lampe compacte en forme de parallélépipède au caractère polyvalent et architectural. De sa structure en acier peint, disponible en taille unique et en trois finitions différentes, y compris le Champagne, la source LED diffuse une lumière bidirectionnelle fonctionnelle et efficace qui crée des jeux d'ombre et de lumière sur le mur. ●FR

Laser ist eine kompakte Lampe in Form eines Parallelepipedes mit vielseitigem und architektonischem Charakter. Durch seine Armatur aus lackiertem Stahl, die in einer Größe und drei unterschiedlichen Ausführungen - jetzt auch Champagner - verfügbar ist, verbreitet die LED-Lichtquelle bidirektionales, funktionelles sowie effektvolles Licht, wodurch ein Spiel aus Licht und Schatten an der Wand entsteht. ●DE

Laser es una lámpara compacta con forma de paralelepípedo con carácter versátil y arquitectónico. De su estructura de acero pintado, disponible en una dimensión y en tres diferentes acabados, ahora incluyendo Champán, la fuente de LED difunde una luz bidireccional funcional y con efecto que crea juegos de luz y sombra en la pared. ●ES

Laser – компактный светильник в форме параллелепипеда с многогранным архитектурным характером. Конструкция светильника выполнена из окрашенной стали, доступной в двух размерах и трех различных вариантах отделки. Светодиодный источник эффективно рассеивает двунаправленный свет, создающий на стене игру света и тени. ●RU

*Laser*是一款四边形的紧凑灯具，具有建筑美感，广泛适用。喷漆钢材的结构，有一种尺寸和三种不同的颜色，如今还有香槟色，LED光源散发着双向的功能灯光，在墙壁上形成光影效果。●ZH

CATEGORY WALL LAMP

Laser

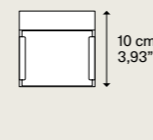
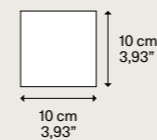

DESIGN Studio Italia Design, 2015

Metal structure
Montatura in metallo

Matte White – 9010
Bianco Opaco – 9010

Matte Black – 9005
Nero Opaco – 9005

Champagne
Champagne

Code
Codice

03652 1030U

03652 2030U

03652 4530U

Light source
Sorgente luminosa

LED
3000 K
17 W
1800 lm
120 V
CRI 92
MacAdam 3-Step

LED included
LED incluso

Net weight 0,60 kg
Peso netto 1,32 lbs

Boxes 1
Colli

Mounts directly to a 4" Standard J-Box – Plate Adaptor included *

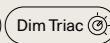
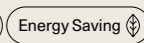

Laser ▾ Wall lamp

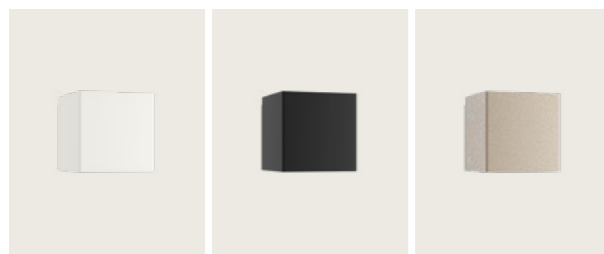

► LED sources with direct power supply to the AC line voltage – driver not required. Dimmable with phase cut dimmer. ► * Recessed backplate available upon request.

► LED con alimentazione diretta a tensione di rete – non necessita di driver. Dimmerabile con varialuce a taglio di fase. ► * Recessed backplate disponibile su richiesta.

Light relationships, relationships with Light
Light plays an essential role in life, both functionally and emotionally. Its energy is silent yet disruptive, and capturing it in design is a challenge that offers endless sources of inspiration. For *Lodes*, *relationships* are at the heart of lighting. *Light* interacts with *people* and *environments*, capable of changing the perception of spaces and create the right atmosphere for any situation. For this reason, the connection that arises between lamps and their users and the bond that develops between light sources and environments have always been at the centre of the company's *research*.

Relazioni di luce, relazioni con la luce

La *luce* gioca un ruolo essenziale nella vita, sia dal punto di vista funzionale che emotivo. La sua energia è silenziosa, ma dirompente: catturarla nel design è una sfida che offre infinite fonti di ispirazione. Per *Lodes* le *relazioni* sono al centro dell'illuminazione. La *luce* interagisce con le *persone* e con gli *ambienti*, può cambiare la percezione degli spazi e creare l'atmosfera giusta per qualsiasi situazione. Per questo, la connessione che nasce tra le lampade e chi le utilizza e il legame che si sviluppa tra le fonti luminose e gli ambienti sono da sempre al centro della *ricerca* dell'azienda.

Lodes Lighting

Light relationships, relationships with Light

Creating lighting *solutions* also means offering control and personalisation to transform rooms according to the needs of the moment and then transforming them again based on the needs of the next moment.

The *LED modules* designed and developed by *Lodes* allow flexible adjustment of light to interact with people and spaces. Various lighting effects contribute to creating different atmospheres, from intimacy for the evening hours to concentration for work, ensuring maximum freedom of expression for users and the maximum enhancement of each environment.

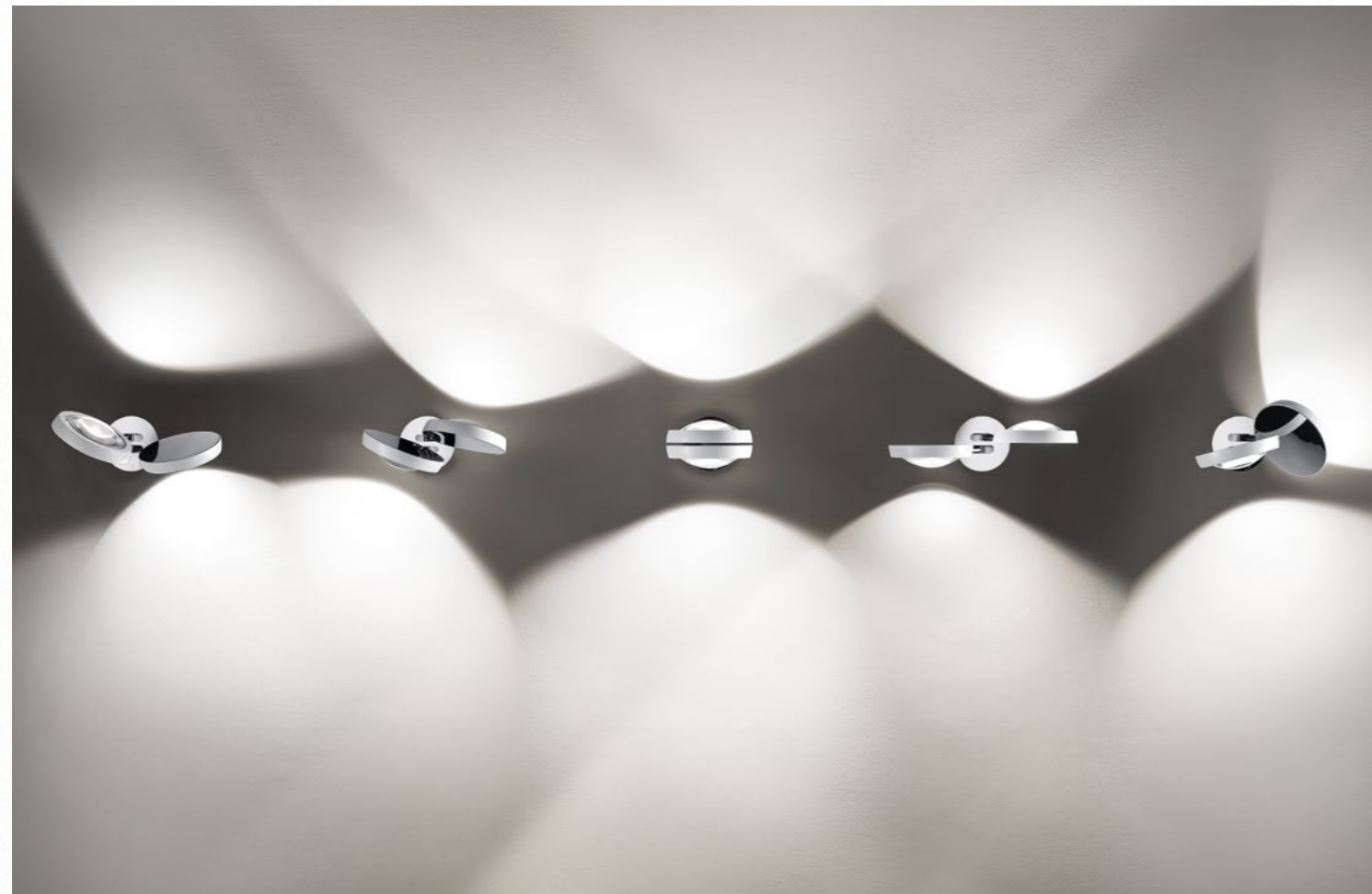

Nautilus, design by Andrea Tosetto

Relazioni di Luce, relazioni con la Luce

Creare *soluzioni* illuminotecniche significa anche offrire controllo e personalizzazione per trasformare gli ambienti in base alle necessità del momento.

E poi per trasformarli ancora in base alle esigenze del momento successivo.

I *moduli LED* progettati e sviluppati da *Lodes* permettono di regolare la luce in modo flessibile affinché interagisca con le persone e con gli spazi.

Vari effetti luminosi concorrono a creare atmosfere diverse, dall'intimità per le ore serali alla concentrazione per il lavoro, per garantire la massima libertà espressiva agli utenti e la massima valorizzazione di ogni ambiente.

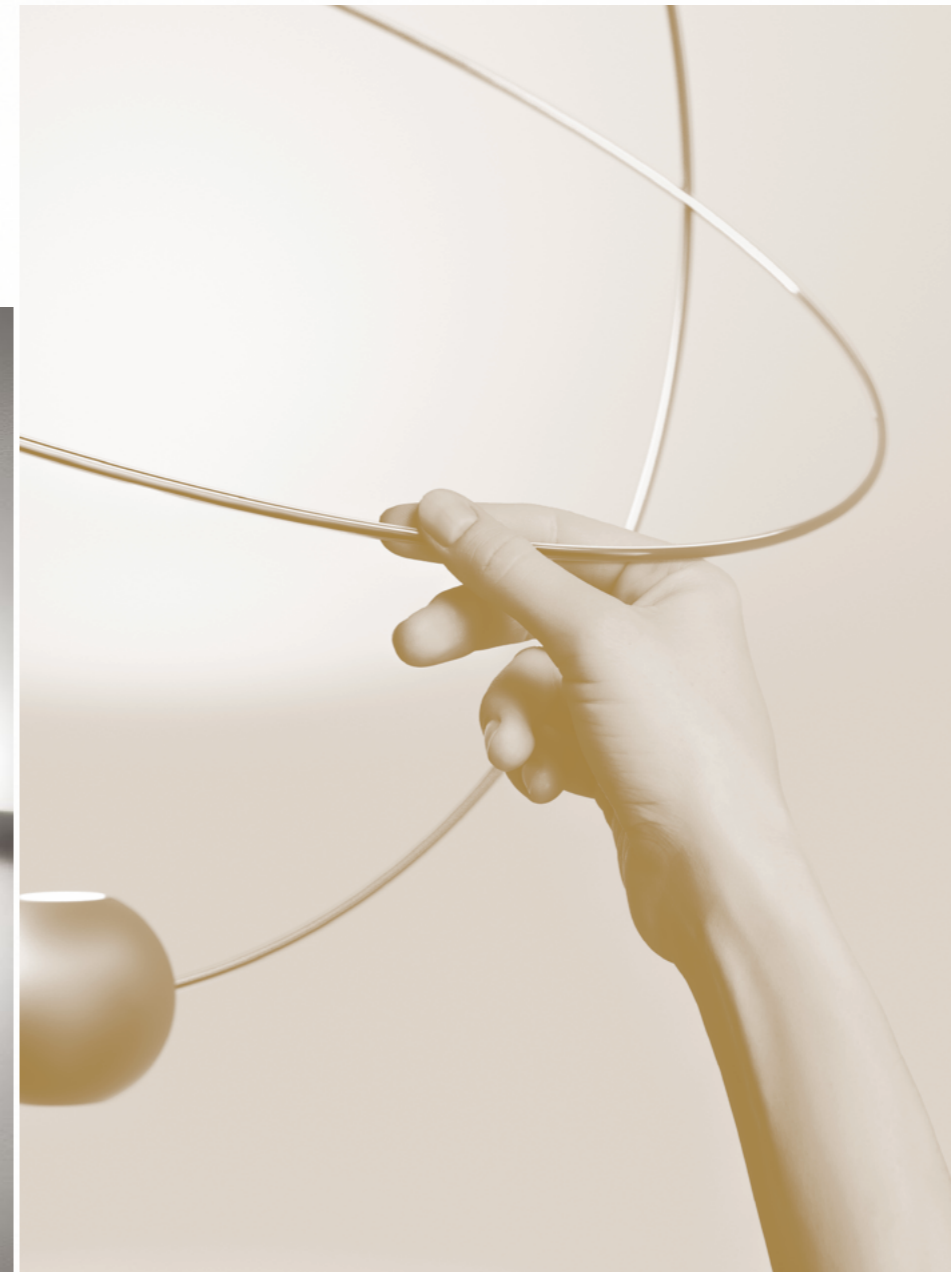

Elara, design by Nika Zupanc

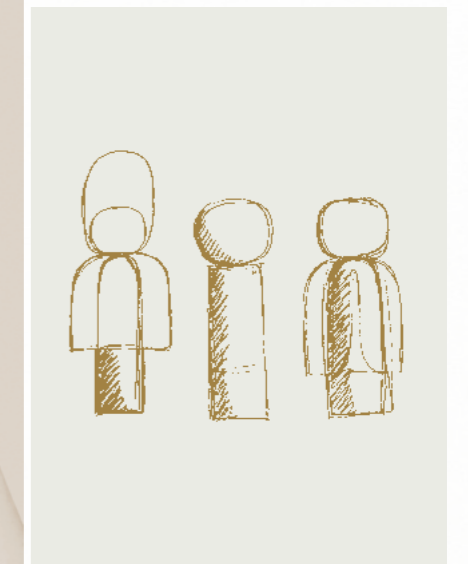

Easy Peasy, design by Luca Nichetto

Versatility: bring the light wherever you want

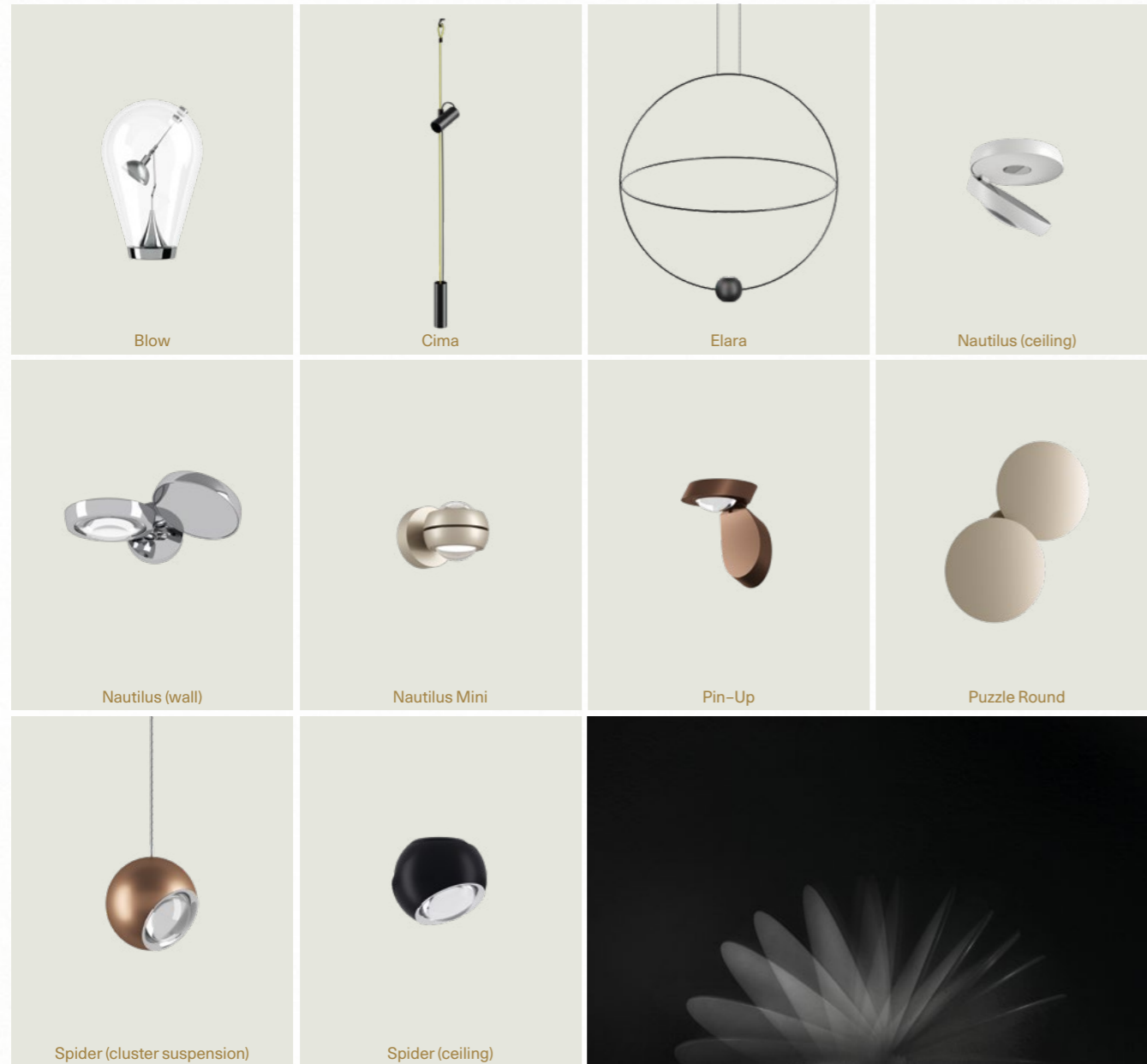

Puzzle Round, design by Studio Italia Design

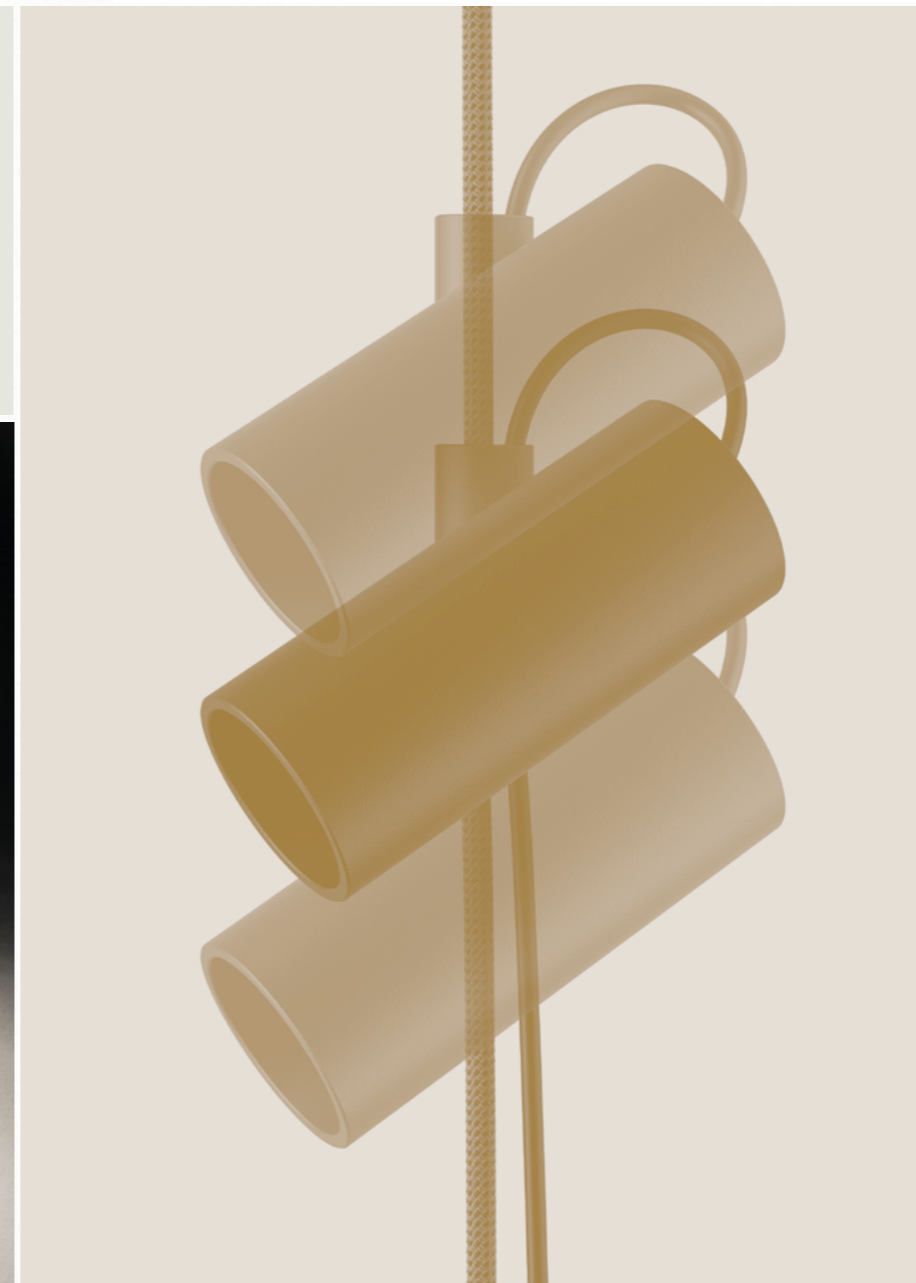

Cima, design by Marco Dessì



Spider, design by Andrea Tosetto

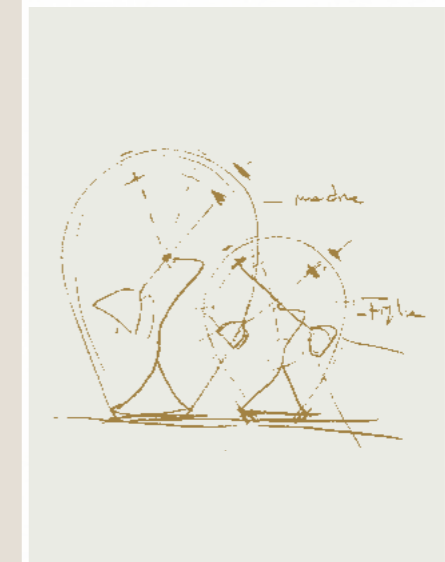

Blow, design by Pio & Tito Toso

Light can change the perception of spaces and generate suggestive plays of light and shadow for a *tailor-made experience*, from functionality to pure decoration. The lighting solutions offered by *Lodes* allow the *light to be directed* laterally or vertically to experience uniform brightness or concentrate the light beam in specific areas, even reaching different heights and angles. Thanks to the simplicity of *interaction*, this *versatility* opens the door to great flexibility of use, creating ever new and customisable atmospheres.

La luce può cambiare la percezione degli spazi e generare suggestivi giochi di luci e ombre per *un'esperienza su misura*, dalla funzionalità alla pura decorazione. Le soluzioni illuminotecniche proposte da *Lodes* permettono di *direzionare la luce* lateralmente o verticalmente per sperimentare una luminosità uniforme o concentrare il fascio di luce in aree specifiche, anche raggiungendo diverse altezze e angolazioni. Grazie alla semplicità di *interazione*, questa *versatilità* apre la porta a una grande flessibilità di utilizzo per dar vita ad atmosfere sempre nuove e personalizzabili.

Dimmer function and Dim-to-Warm

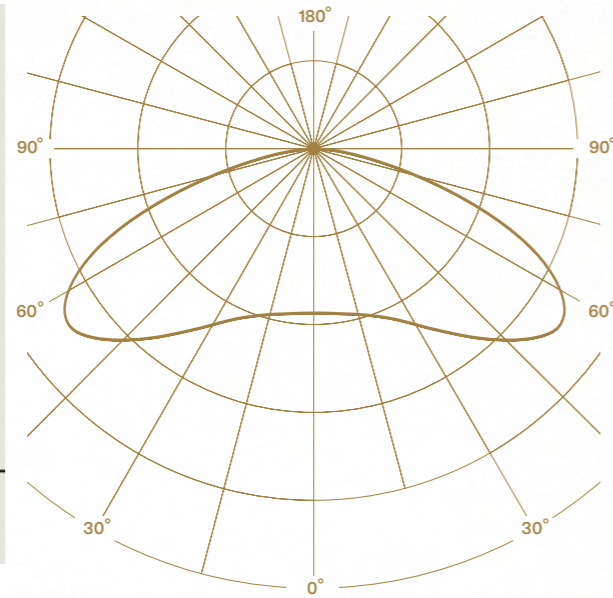

Cono di Luce, design by Ron Arad

There is a right light for every emotion and a right brightness for every time of day. To transform every space into the perfect ambience, lighting becomes essential. The *dimmer function* allows modulation of light intensity, finding the right combination between brightest brightness and almost total darkness. *Dim-to-warm* adds an additional level of customisation to adjust the warmth of the light and create lighting experiences to suit any situation and need. All LEDs designed by *Lodes* guarantee constant and uniform brightness at any intensity level.

C'è una luce giusta per ogni emozione e una luminosità adatta a ogni momento della giornata: per trasformare ogni spazio nell'ambiente perfetto, l'illuminazione diventa essenziale. La *funzione dimmer* consente di modulare l'intensità della luce, trovando la giusta combinazione tra la luminosità più intensa e il buio quasi totale. Il *dim-to-warm* aggiunge un ulteriore livello di personalizzazione per regolare il calore della luce e creare esperienze luminose adatte a qualsiasi situazione e necessità. Tutti i LED progettati da *Lodes* garantiscono una luminosità costante e uniforme a qualsiasi livello di intensità.



Hover, design by YOY

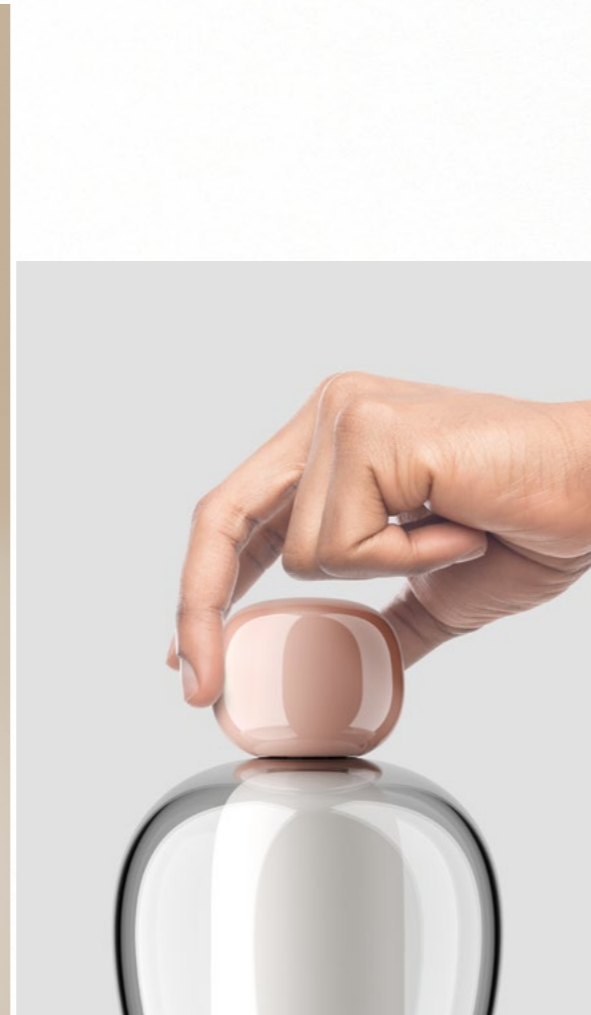

Easy Peasy, design by Luca Nichetto



Flar, design by Patrick Norguet

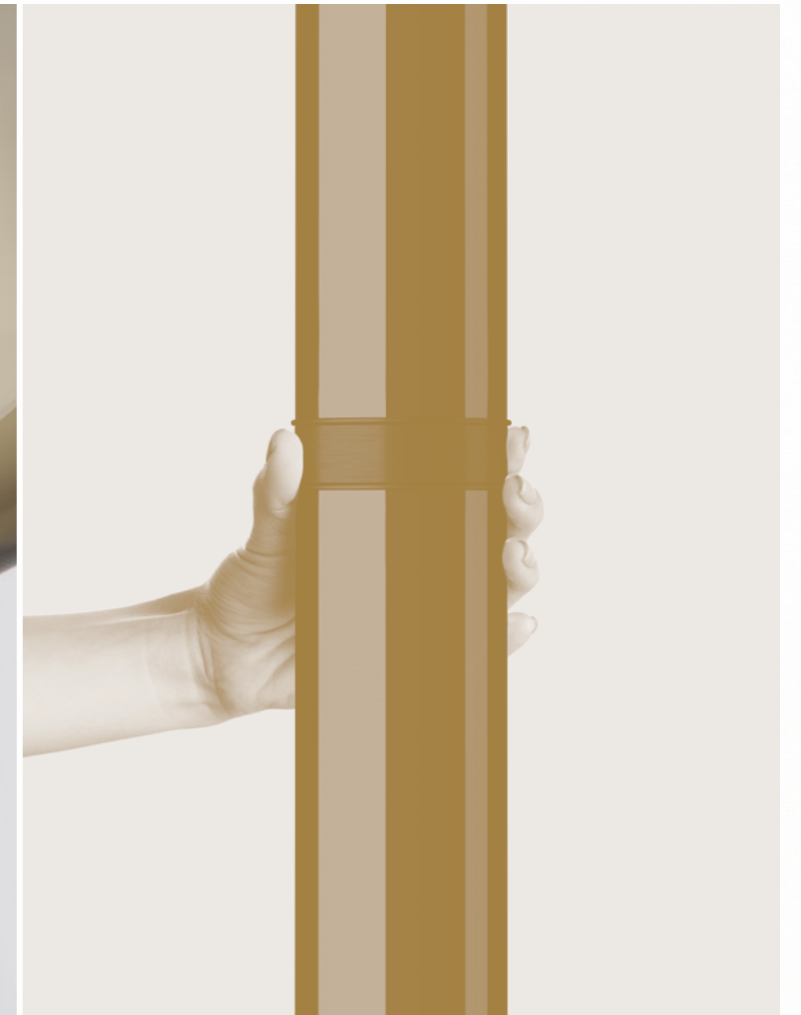

Croma, design by Luca Nichetto

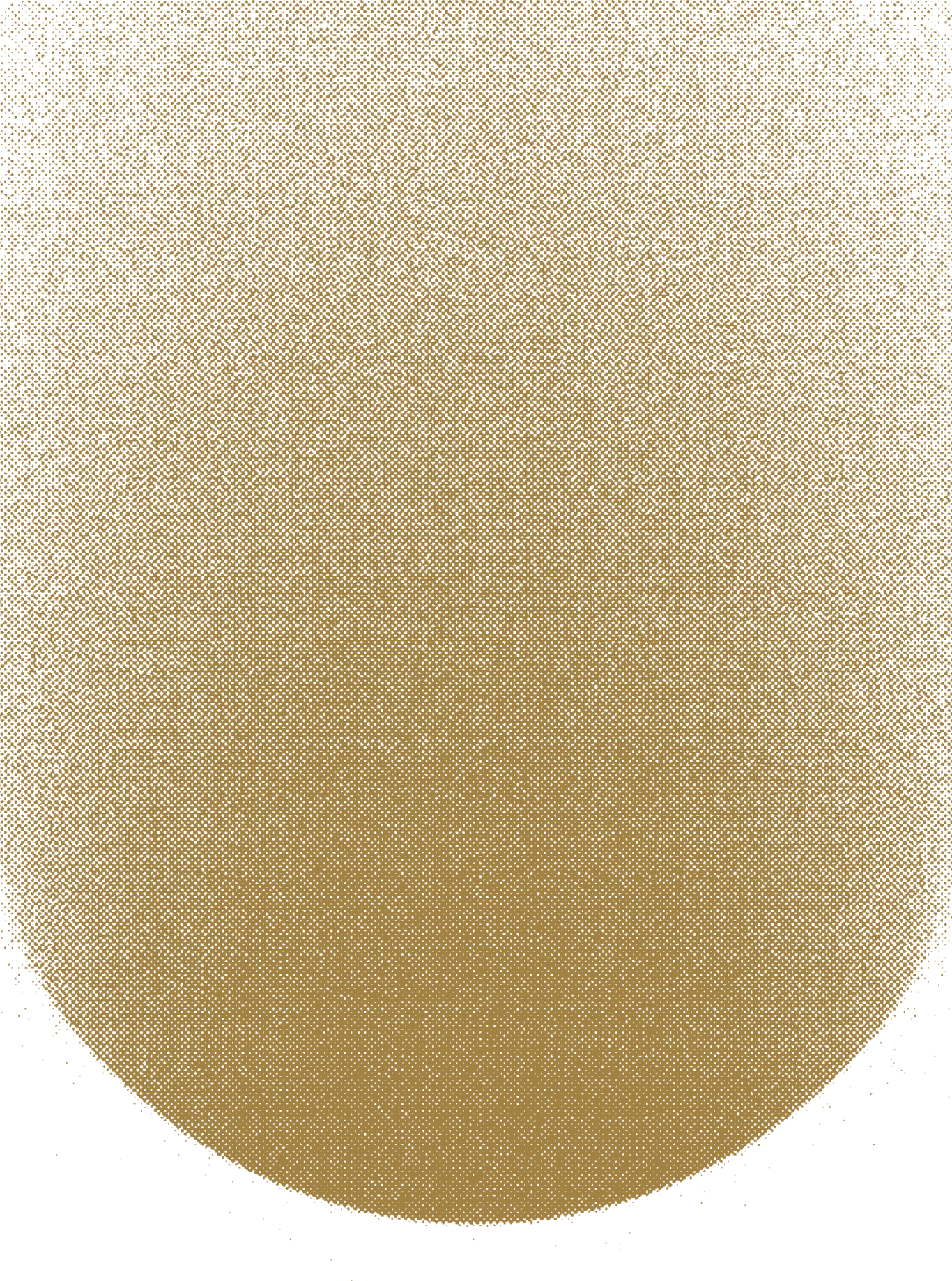

For *Lodes*, the quality of light materialises in offering the best possible light in every context, whether residential or work-related.

Per *Lodes*, la qualità della luce si concretizza nell'offrire la migliore luce possibile in ogni contesto, che sia abitativo o di lavoro.

Personalisation of light

Hover, design by YOY, 2022

The *Hover* table and floor lamps feature a lamp shade that looks as if it is detached from the base, connected seamlessly by a single cable that runs through the stem and comes out of the other end. The end result creates an illusion that the light source is almost weightless and floating in the air, like a balloon. *Hover* features a dimmer controlled by a power switch on the upper end of the stem; users can simply touch the top of the stem to modulate the intensity of the light. All typically external technical functions have been carefully incorporated within the lamp's internal structure. Additionally, the power supply comes in the form of a USB cable.

● Spec sheet p. 379

Le lampade da tavolo e da terra *Hover* presentano un paralume che sembra separato dalla base, collegato perfettamente da un unico cavo che attraversa lo stelo per poi uscirne. Il risultato finale crea l'illusione che la sorgente luminosa sia quasi priva di peso e fluttui nell'aria, come un palloncino. *Hover* è dotata di un dimmer controllato da un interruttore di alimentazione posto all'estremità superiore dello stelo; gli utenti possono semplicemente toccare la parte superiore dello stelo per modulare l'intensità della luce. Tutte le funzioni tecniche tipicamente esterne sono state accuratamente incorporate nella struttura interna della lampada. Inoltre, l'alimentazione è fornita grazie ad un cavo USB.

HOVER	CATEGORY LAMP		TYPE OF LIGHT	
	Table	Tavolo	Diffused light	Luce diffusa
	Floor	Terra		







1



2

1 Hover, the lamp shade is connected seamlessly by a single cable that runs through the stem and comes out of the other end.
 2 Hover, switch on and off and dim the light intensity.



1



2

1 Hover, USB socket.
2 Hover table, FINISH Matte White.



377

Table lamp

Hover table, FINISH Matte White.

Hover

L'abat-jour des lampes de table et des lampadaires *Hover* semble séparé de la base et parfaitement relié par un câble unique qui traverse entièrement la tige. Le résultat final crée l'illusion d'une source lumineuse qui flotte dans l'air quasiment en apesanteur, comme un ballon. *Hover* est équipé d'un gradateur commandé par un interrupteur d'alimentation situé à l'extrémité supérieure de la tige ; les utilisateurs n'ont qu'à toucher le haut de la tige pour moduler l'intensité de la lumière. Toutes les fonctions techniques habituellement externes ont été soigneusement intégrées dans la structure interne de la lampe. En outre, l'alimentation est fournie via un câble USB. Disponible en lampe de table ou en lampadaire, *Hover* convient à différents usages, comme lampe de bureau, de table basse ou à côté d'un canapé. La version au sol peut également être installée dans des espaces publics tels qu'un lounge d'aéroport, une chambre d'hôtel ou un hall. ● FR

Die Tisch- und Stehleuchten *Hover* verfügen über einen Leuchtschirm, der vom Sockel getrennt zu sein scheint, verbunden auf perfekte Weise durch ein einziges Kabel, das durch den Schaft hindurch und aus ihm herausführt. Das Endergebnis erzeugt die Illusion, dass die Lichtquelle fast schwerelos ist und wie ein Ballon in der Luft schwebt. *Hover* ist mit einem Dimmer ausgestattet, der über einen Schalter am oberen Ende des Schaftes reguliert wird; die Benutzer können die Lichtintensität durch einfaches Berühren des oberen Endes des Schaftes einstellen. Alle typischen externen technischen Funktionen wurden sorgfältig in die innere Struktur der Leuchte integriert. Außerdem erfolgt die Stromversorgung über ein USB-Kabel. Erhältlich als Tisch- oder Stehleuchte, eignet sich *Hover* für verschiedene Verwendungszwecke, z. B. auf einem Schreibtisch, einem Beistelltisch oder neben einem Sofa. Die Bodenversion kann auch in öffentlichen Räumen wie einer Flughafenlounge, einem Hotelzimmer oder einer Empfangshalle eingesetzt werden. ● DE

Las lámparas de sobremesa y de pie *Hover* poseen una pantalla que parece separada de la base, conectada perfectamente por un solo cable que atraviesa la barra y luego sale. El resultado final da la sensación de que la fuente luminosa prácticamente no pesa y flota en el aire, como un globo. *Hover* está equipada con un regulador que controla un interruptor de alimentación situado en el extremo superior de la barra; los usuarios, simplemente tocando la parte superior de la barra, pueden regular la intensidad de la luz. Todas las funciones técnicas que normalmente están fuera se han incorporado minuciosamente en la estructura interna de la lámpara. Además, la alimentación se suministra gracias a un cable USB. *Hover*, disponible como lámpara de sobremesa o de pie, se adapta a distintos usos, como por ejemplo en un escritorio, una mesita o junto a un sofá. La versión de pie también se puede utilizar en espacios públicos como en la sala de un aeropuerto, una habitación de hotel o un vestíbulo. ● ES

Настольные лампы и торшеры *Hover* имеют абажур, который кажется отделенным от основания и соединенным одним кабелем, пересекающим стержень, а затем выходящим наружу. В результате возникает иллюзия невесомости источника света, парящего в воздухе, как воздушный шар. *Hover* оснащен диммером, управляемым выключателем, расположенным на верхнем конце стержня; пользователи могут отрегулировать интенсивность света, просто прикоснувшись к верхней части стержня. Все технические функции, обычно находящиеся снаружи, были встроены во внутреннюю структуру светильника. Питание также подается по кабелю USB. *Hover* выпускается в виде настольной лампы или торшера, и подходит для различного применения, на письменном столе, журнальном столике или рядом с диваном. Напольный вариант может также устанавливаться в общественных зданиях, например в зале аэропорта, в гостиничном номере или в холле. ● RU

*Hover*的台灯款和落地灯款均带有一个看似与底座分开的灯罩，但灯罩与底座之间却由一根从灯罩部位穿插而过的单根线缆完美连接。最终结果营造一种幻觉，光源仿佛几乎没有重量且会像气球一般漂浮于空中。*Hover*配有一部由位于灯罩上端的电源开关控制的调光器；用户只需轻触灯罩顶部便可调节光的强度。所有典型的外部技术功能均已巧妙整合至灯件的内部结构之中。此外，电源供给是通过一根USB线缆完成的。*Hover*提供台灯或落地灯两个版本，适用于不同用途，例如放在书桌、咖啡桌上或沙发近旁。落地灯版本也可用于机场休息室、酒店房间或大堂等公共场所。● ZH

CATEGORY FLOOR LAMP

Hover

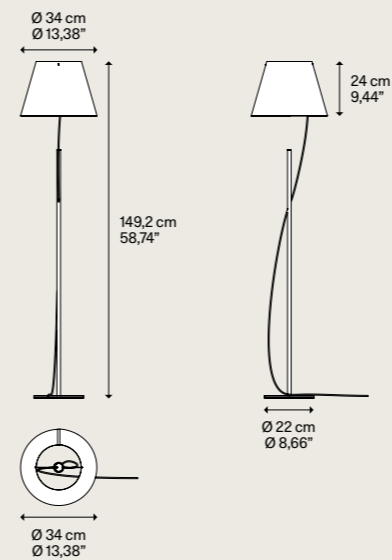

Net weight	3,86 kg	Boxes	1
Peso netto	8,51 lbs	Colli	1

CATEGORY TABLE LAMP

Hover

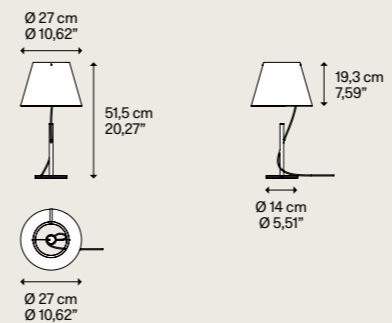

Net weight	1,68 kg	Boxes	1
Peso netto	3,70 lbs	Colli	1

DESIGN YOY, 2022

Metal structure
Montatura in metallo

Matte White
Bianco Opaco

Paper diffuser
Diffusore in carta

Matte White
Bianco Opaco

Code
Codice

18471 1027

Light source
Sorgente luminosa

LED
2700 K
6,5 W
1000 lm
5 V
2 A
CRI 90
MacAdam 3-Step

LED, driver and touch dimmer included
LED, driver e touch dimmer inclusi

IP20 Energy Saving Touch Dim

DESIGN YOY, 2022

Metal structure
Montatura in metallo

Matte White
Bianco Opaco

Paper diffuser
Diffusore in carta

Matte White
Bianco Opaco

Code
Codice

18480 1027

Light source
Sorgente luminosa

LED
2700 K
6,5 W
1000 lm
5 V
2 A
CRI 90
MacAdam 3-Step

LED, driver and touch dimmer included
LED, driver e touch dimmer inclusi

IP20 Energy Saving Touch Dim

Hover » Floor lamp

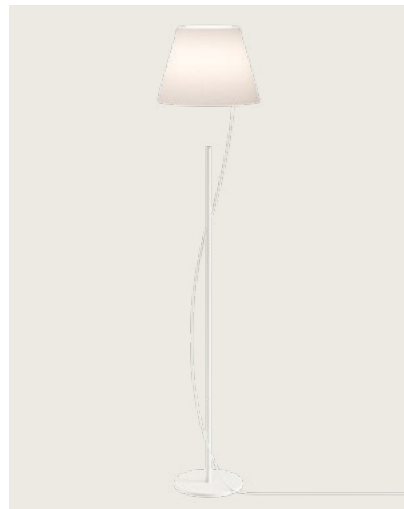

Hover » Table lamp



Blow, design by Pio & Tito Toso, 2005

As light as a breath, *Blow* is an ethereal and original table lamp. Made from blown glass, it contains a bright light that can be directed inside the diffuser to create ever-different beams. Perfect for reading or furnishing personal and intimate spaces.

● Spec sheet p. 385

Leggera come un respiro, *Blow* è una lampada da tavolo eterea e ingegnosa. Realizzata in vetro soffiato, contiene una luce vivace che si può orientare all'interno del diffusore per creare fasci luminosi ogni volta diversi. Ideale per leggere e per arredare spazi personali e intimi.



BLOW	CATEGORY LAMP		TYPE OF LIGHT	
	Table	Tavolo	Symmetrical diffused light Adjustable	Luce simmetrica diffusa Orientabile





Légère comme un souffle, *Blow* est une lampe sur table éthérée et ingénieuse. Réalisée en verre soufflé, elle renferme une lumière vivace qui peut être orienté à l'intérieur du diffuseur pour créer des faisceaux de lumière tous différents. Idéale pour la lecture et pour décorer les espaces personnels et intimes. ●FR

So leicht wie der Atem ist *Blow* eine himmlische und erfinderische Tischlampe. Hergestellt aus mundgeblasenem Glas, enthält die Leuchte ein lebhaftes Licht, das innen im Diffusor ausgerichtet werden kann, um stets neue Lichtstreifen entstehen zu lassen. Ideal zum Lesen und zum Einrichten persönlicher und intimer Räume. ●DE

Ligera como un suspiro, *Blow* es una etérea ingeniosa lámpara de sobremesa. Fabricada en vidrio soplado, contiene una luz brillante que puede orientarse dentro del difusor para crear diferentes haces de luz cada vez. Ideal para leer y para decorar espacios personales e íntimos. ●ES

Легкий как дыхание, *Blow* – это изящный и очень оригинальный настольный светильник. Этот светильник, изготовленный из выдувного стекла, заключает в себе живой и динамичный свет, который можно ориентировать внутри диффузора для создания всякий раз других световых пучков. Идеально подходит для чтения и для оформления личных и интимных пространств. ●RU

轻如呼吸, *Blow*是一款灵动而巧妙的台灯。由吹制玻璃制成, 含有充满活力光线, 可以将其定向到灯罩的内部, 每次发出不同的光束。阅读和布置个人和私密空间的理想之选。●ZH

CATEGORY TABLE LAMP

Blow

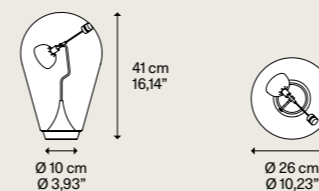

DESIGN Pio & Tito Toso, 2005

Metal structure
Montatura in metallo

Chrome
Cromo

Blown glass diffuser
Diffusore in vetro soffiato

Clear
Trasparente

Code
Codice

00880 27U

Light source
Sorgente luminosa

LED
2700 K
4,5 W
500 lm
500 mA
CRI 90
MacAdam 3-Step
LED and driver included
LED e driver inclusi

Net weight 4,00 kg
Peso netto 8,82 lbs

Boxes 1
Colli 1

IP20 Energy Saving

Adjustable light
Luce orientabile

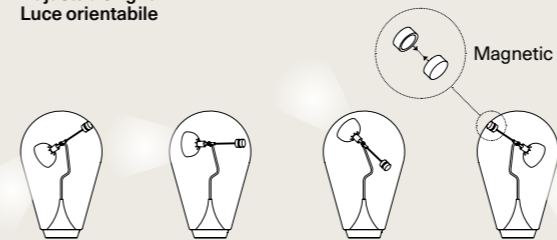

Blow ▾ Table lamp



Easy Peasy, design by Luca Nichetto, 2020

With a strong personality and a sculptural form reminiscing the shape of bells, *Easy Peasy* is a set of portable and rechargeable table lamps, consisting of two rounded elements, a body and a knob. Made of blown glass, *Easy Peasy* allows for personal customisation of the living spaces. Its portability, different shapes and colours, and the dim-to-warm functionality of its light source allow users to connect, play and interact with the variable configuration options. It is not just a table lamp: it is a real character to interact with!

● Spec sheet p. 393

Con una spiccata personalità e una linea sculturale che ricorda la forma delle campane, *Easy Peasy* è un set di lampade da tavolo portatili e ricaricabili, composte da due elementi stondati, un corpo e un pomolo. Realizzata in vetro soffiato, *Easy Peasy* permette la personalizzazione individuale degli spazi abitativi. La sua portabilità, le diverse forme e colori e la funzione dim-to-warm della sorgente luminosa a LED permettono agli utenti di interagire, giocare e dialogare con le differenti possibilità di configurazione della luce. Non è solo una lampada da tavolo: è un vero e proprio personaggio con cui interagire!



EASY PEASY	CATEGORY LAMP	TYPE OF LIGHT
	Cordless table lamp Lampada da tavolo senza filo	Diffused light Luce diffusa







1

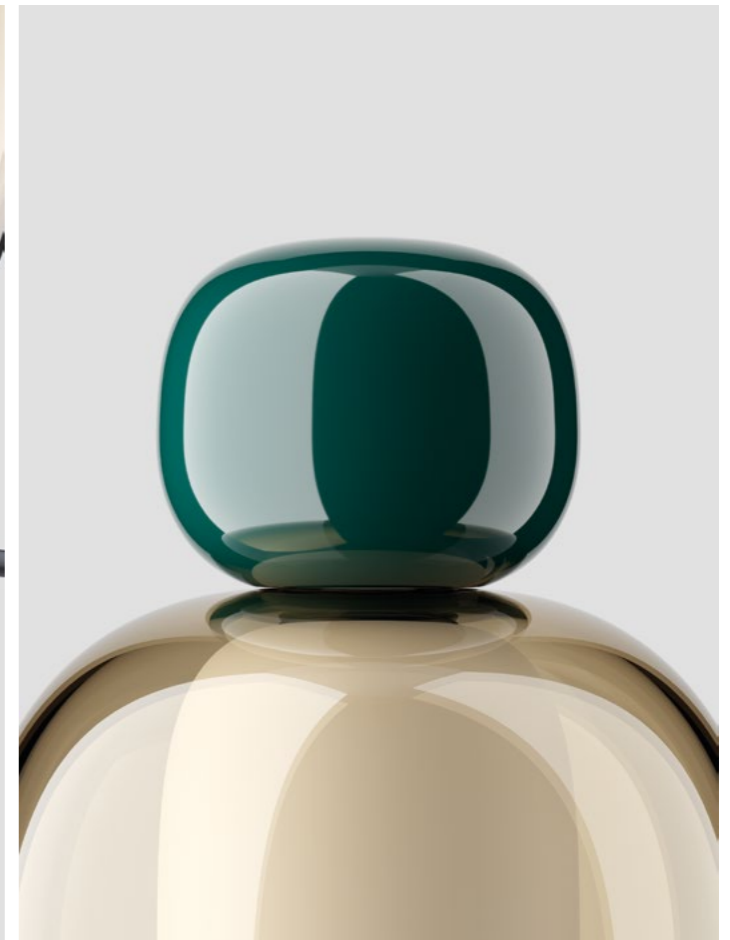

2

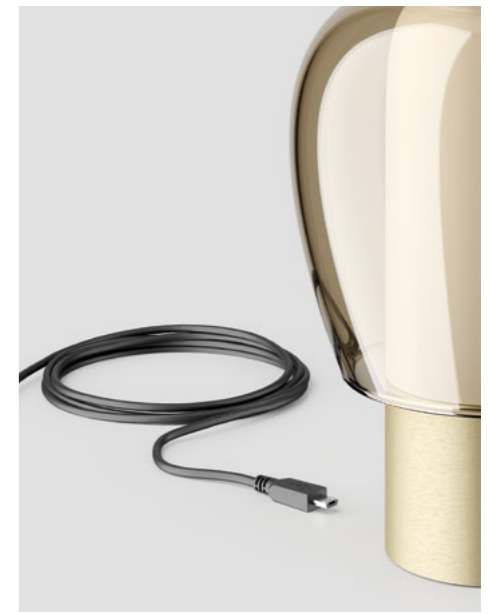

3

- 1 Easy Peasy, micro USB socket.
- 2 Easy Peasy, knob, glass bell, diffuser.
- 3 Easy Peasy, portable and rechargeable table lamp.

Avec sa forte personnalité et une ligne sculpturale qui rappelle la forme des cloches, *Easy Peasy* est un ensemble de lampes sur table portables et rechargeables, composé de deux éléments arrondis, un corps et un pommeau. Réalisée en verre soufflé, *Easy Peasy* permet la personnalisation individuelle des espaces de vie. Sa portabilité, ses différentes formes et couleurs et la fonction « *dim-to-warm* » de la source lumineuse à LED permettent aux utilisateurs d'interagir, de jouer et de dialoguer avec les différentes possibilités de configuration de la lumière. Ce n'est pas seulement une lampe de table : c'est un véritable personnage avec lequel on peut interagir! ● FR

Mit einer besonderen Persönlichkeit und einer skulpturalen Linie, die an die Form einer Glocke erinnert, ist *Easy Peasy* ein Set aus mitnehmbaren und aufladbaren Tischleuchten, bestehend aus zwei abgerundeten Elementen, einem Korpus und einem Knauf. Aus geblasenem Glas hergestellt, ermöglicht *Easy Peasy* eine individuelle Personalisierung der Wohnräume. Die Mitnehmbarkeit, die verschiedenen Formen und Farben sowie die Funktion *Dim-to-warm* der LED-Lichtquelle ermöglichen den Nutzern mit den verschiedenen Konfigurationen für das Licht zu interagieren, zu spielen und in Dialog zu treten. Es ist nicht nur eine Tischlampe: Es ist eine echte Figur, mit der man interagieren kann. ● DE

Con una marcada personalidad y una línea escultural que recuerda la forma de las campanas, *Easy Peasy* es un set de lámparas de sobremesa portátiles y recargables, compuestas por dos elementos redondeados, un cuerpo y un pomo. Realizada en vidrio soplado, *Easy Peasy* permite la personalización individual de los espacios habitacionales. Su portabilidad, las diversas formas y colores y la función *dim-to-warm* de la fuente luminosa a LED permiten a los usuarios interactuar, jugar y dialogar con las diferentes posibilidades de configuración de la luz. No es sólo una lámpara de mesa: es un personaje real con el que interactuar. ● ES

Обладающие ярко выраженной индивидуальностью и скульптурным силуэтом, напоминающим форму колокола, светильники *Easy Peasy* – это серия портативных перезаряжаемых настольных ламп, состоящих из двух закругленных элементов, корпуса и ручки. Лампы *Easy Peasy*, изготовленные из выдувного стекла, придают оформлению жилого пространства самобытность и оригинальность. Портативность, разнообразие форм и цветов, а также функция *dim-to-warm* источника света LED позволяют пользователям взаимодействовать, фантазировать и применять возможности различных конфигураций освещения. Это не только настольный светильник – это настоящий персонаж с которым можно контактировать. ● RU

*Easy Peasy*具有强烈的个性和雕塑感，酷似铃铛的形状，它是一组便携式可充电台灯，由两个圆形元素组成，一个主体和一个圆头。台灯由吹制玻璃制成，*Easy Peasy*可实现生活空间的个性化定制。它的便携性、不同的形状和颜色及其LED光源*dim-to-warm*的调光功能，允许用户与不同的灯光配置选项进行交互、游戏和对话。*Easy Peasy*不仅是盏台灯：它是一个具有个性能与空间互动的活泼伙伴 ● ZH



Easy Peasy, packaging

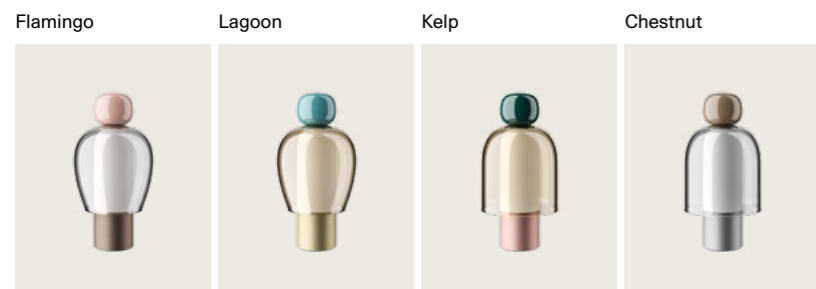

CATEGORY CORDLESS TABLE LAMP

Easy Peasy

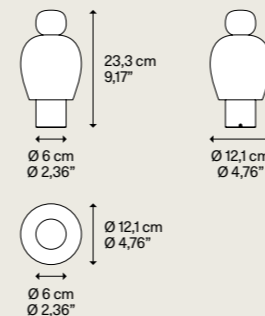
Light source
Sorgente luminosa

LED
Dim-to-Warm
FROM 2200 K
TO 2700 K
5 W
380 lm
2000 mA Battery
CRI 90
MacAdam 3-Step

LED and battery included
LED e batteria inclusi

Battery charging time
Tempo di ricarica

Power supply
1A ▶ 180 min

Battery life
Durata batteria

Full power 100% ▶ 6h
Half power 50% ▶ 10h
Min power 10% ▶ 19h

Net weight 0,85 kg
Peso netto 1,87 lbs

Boxes 1
Colli 1

IP20 Energy Saving Dim-to-Warm

Easy Peasy

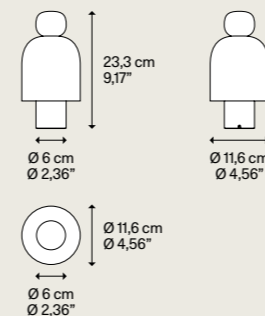
Light source
Sorgente luminosa

LED
Dim-to-Warm
FROM 2200 K
TO 2700 K
5 W
380 lm
2000 mA Battery
CRI 90
MacAdam 3-Step

LED and battery included
LED e batteria inclusi

Battery charging time
Tempo di ricarica

Power supply
1A ▶ 180 min

Battery life
Durata batteria

Full power 100% ▶ 6h
Half power 50% ▶ 10h
Min power 10% ▶ 19h

Net weight 0,85 kg
Peso netto 1,87 lbs

Boxes 1
Colli 1

IP20 Energy Saving Dim-to-Warm

DESIGN Luca Nichetto, 2020

Flamingo

Technopolymer knob
Pomolo in tecnopolimero

Pink
Rosa

Blown glass shade
Cappello in vetro soffiato

Grey
Grigio

Metal base
Base in metallo

Brushed Bronze
Bronzo Spazzolato

Code
Codice

17081 6226U

Lagoon

Technopolymer knob
Pomolo in tecnopolimero

Turquoise
Turchese

Blown glass shade
Cappello in vetro soffiato

Honey
Miele

Metal base
Base in metallo

Brushed Gold
Oro Spazzolato

Code
Codice

17081 8126U

Kelp

Technopolymer knob
Pomolo in tecnopolimero

Green
Verde

Blown glass shade
Cappello in vetro soffiato

Honey
Miele

Metal base
Base in metallo

Brushed Rose Gold
Oro Rosa Spazzolato

Code
Codice

17081 7226U

Chestnut

Technopolymer knob
Pomolo in tecnopolimero

Taupe
Grigio Caldo

Blown glass shade
Cappello in vetro soffiato

Grey
Grigio

Metal base
Base in metallo

Brushed Palladium
Palladio Spazzolato

Code
Codice

17081 3826U

Croma, *design by* Luca Nichetto, 2021

Taking its name from the Italian word for a ‘quaver’ or ‘eighth’, *Croma* reflects the dynamism of the musical note in its slender frame. It features a conical base that provides stability and a sleek body which casts a powerful ray of light from its LED source. A ring conveniently positioned halfway up the stem allows the user to control the LED module, and to utilise its dim-to-warm function. Its two unique metallic ombré colourways and the two texturised white and black finishes make *Croma* suitable for a variety of environments, including residential, hotel and hospitality.

● Spec sheet p. 403

La nuova lampada da terra richiama nel nome la “*croma*” o “*ottavo*”: la sua struttura slanciata che proietta fasci di luce lungo la parete verso il soffitto evoca il dinamismo della nota musicale. *Croma* ha una base conica che le conferisce stabilità e una silhouette longilinea che proietta un potente raggio di luce dalla sorgente LED. Un anello posizionato a metà altezza dello stelo consente all’utente di regolare il modulo a LED e gestire la funzione dim-to-warm. Le due finiture metallizzate ombré, e le due tonalità testurizzate bianco e nero rendono *Croma* adatta a una varietà di ambienti, dal residenziale all’hotel e ospitalità.

CROMO	CATEGORY LAMP		TYPE OF LIGHT	
	Floor	Terra	Symmetrical diffused light Indirect light	Luce simmetrica diffusa Luce indiretta





Croma, FINISH Bronze.



1

2

397 Floor lamp

- 1 Croma, light source.
- 2 Croma, turn on and off, dim light intensity and warmth.

Croma



1



399

Floor lamp

Croma

1 Croma, turn on and off, dim light intensity and warmth.
 2 Croma, FINISHES Matte Black and Matte White

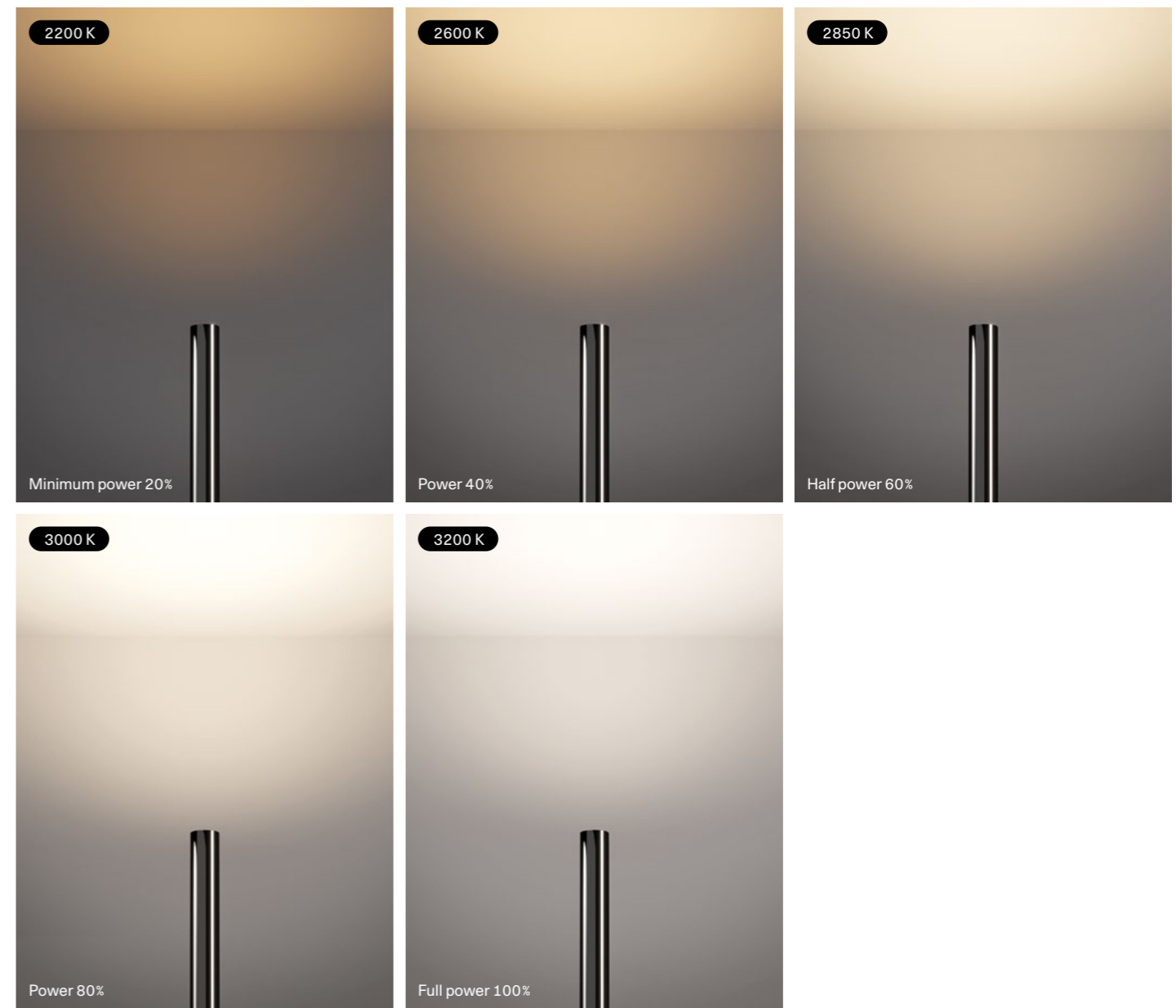

Le nouveau lampadaire prend son nom du mot italien désignant une *croche* ou une *hampe* : sa structure élançée dissipe les faisceaux de lumière vers le haut du mur et le plafond pour évoquer le dynamisme de la note de musique. *Croma* s'appuie sur une base conique qui assure sa stabilité et lui donne une allure longiligne qui projette un puissant rayon de lumière de la source LED. Un anneau placé à mi-hauteur de la hampe permet à l'utilisateur de contrôler le module LED et de gérer la fonction dim-to-warm. Grâce aux deux nouvelles finitions métallisées ombré et aux deux tonalités texturisées blanche et noire, *Croma* épouse toute une variété d'ambiances, du résidentiel à l'hôtellerie et à l'accueil. ●FR

Der Name der neuen Stehleuchte leitet sich vom italienischen Wort für "Achtelnote" oder "Achtel" ab: Ihre schlanke Struktur, die die Lichtstrahlen entlang der Wand in Richtung Decke projiziert, spiegelt die Dynamik der Musiknote wider. *Croma* hat einen konischen Sockel, der ihr Stabilität verleiht und eine langgestreckte Silhouette, die einen kraftvollen Lichtstrahl aus dem LED-Leuchtmittel abgibt. Ein auf halber Höhe des Ständers angebrachter Ring ermöglicht dem Benutzer, das LED-Modul zu steuern und die Dim-to-Warm-Funktion zu nutzen. Metallische Ombré Ausführungen und zwei strukturierte Schwarz- und Weißtöne ermöglichen den Einsatz von *Croma* in einer Vielzahl von Umgebungen, vom Wohnbereich bis hin zu Hotels und Hospitality. ●DE

La nueva lámpara de pie evoca en el nombre *lacorchea* o *octava*: su estructura estilizada que proyecta haces de luz en la pared hacia el techo evoca el dinamismo de la nota musical. *Croma* descansa sobre una base cónica queda estabilidad a su silueta alargada que proyecta un potente rayo de luz de la fuente LED. Un anillo situado a media altura del pie le permite al usuario regular el módulo LED y controlar la función dim-to-warm. Los dos nuevos acabados metalizados ombré y los dos colores texturizados blanco y negro hacen que *Croma* sea apropiada para distintos ambientes, del residencial pasando por el hotelero a la hostelería. ●ES

Новый торшер напоминает своим названием итальянское слово «срома» или «восьмой»: его утонченная структура, проецирующая лучи света вдоль стены к потолку, ассоциируется с динамизмом музыкальной ноты. *Croma* имеет коническое основание, которое придает лампе устойчивость и утонченность силуэта. Лампа проецирует мощный луч света от светодиодного источника. Кольцо, расположенное на середине ноги торшера, позволяет пользователю регулировать светодиодный модуль и управлять функцией dim-to-warm. Две новые металлизированные отделки деграде и две новые текстурированные тональности черного и белого делают лампу *Croma* подходящей для с амых разных применений, от жилых помещений до отелей и структур по приему гостей. ●RU

新款落地灯呼应“颤音”或“八分音符”之名:纤细修长的结构沿着墙壁向天花板散射光束,唤起音符之活力。*Croma*有一个锥形底座,该底座为其赋予稳定性以及一个可从LED光源投射出强烈光线的纤长轮廓。一只位于灯茎一半处的圆环使用户能够调整LED模块并管理从暗到暖的调光功能。两种金属渐变效果饰面以及纯白色和黑色两种纹理色调,使*Croma*适用于包括住宅、酒店及招待场所在内的各类环境。●ZH

CATEGORY FLOOR LAMP

Croma

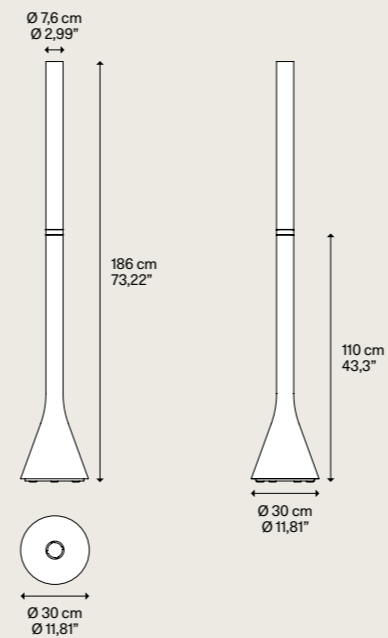

Net weight 15,00 kg
Peso netto 33,07 lbs

Boxes 1
Colli 1

DESIGN Luca Nichetto, 2021

Metal structure
Montatura in metallo

- Matte White - 9010
Bianco Opaco - 9010
- Matte Black - 9005
Nero Opaco - 9005
- Bronze
Bronzo
- Green
Verde

Code
Codice

- 17270 1000U
- 17270 2000U
- 17270 3400U
- 17270 7000U

Light source
Sorgente luminosa

LED
Dim-to-Warm
FROM 2200 K
TO 3200 K
42 W
5200 lm
120 V
CRI 90
MacAdam 3-Step

Dim-to-Warm	Color Temperature (K)	Lumen (lm)
▶ 20%	2200 K	1400 lm
▶ 40%	2600 K	2400 lm
▶ 60%	2850 K	3550 lm
▶ 80%	3000 K	4600 lm
▶ 100%	3200 K	5600 lm

LED included
LED incluso

IP20

Energy Saving

Dim-to-Warm



Croma ▾ Floor lamp



Flar, design by Patrick Norguet, 2022

The name *Flar* evokes images of a flare or ‘flamboiemnt’ in French – an intense blaze or burst of light. Inspired by traditional storm lanterns which use glass pipes to protect the flame, *Flar* comprises a 3D laser cut steel base which opens like a flower, leading to a charmingly imperfect blown glass diffuser available in two sizes, 45 and 60 cm. *Flar* features a dimmer controlled with the cable mounted power switch, allowing users to modulate the intensity of the light to create their ideal lighting scheme. The two sizes offer an opportunity to play with scale to create a unique composition for a hotel lounge or retail space.

● Spec sheet p. 413

Il nome *Flar* evoca l’immagine di uno sfavillio o “flamboiemnt”, che in francese indica un intenso bagliore o squarcio di luce. Ispirata alle tradizionali lanterne antivento dotate di tubi in vetro per proteggere la fiamma, *Flar* si poggia su una base in acciaio, realizzata con la tecnologia del taglio laser 3D, che si schiude come un fiore e accoglie un diffusore in vetro soffiato dall’effetto piacevolmente imperfetto. Disponibile nelle due versioni da 45 e 60 cm, *Flar* è provvista di un varialuce regolabile dall’interruttore montato sul cavo, che consente all’utente di modulare l’intensità della luce in base alle proprie preferenze. Le due dimensioni offrono la possibilità di giocare con le proporzioni, creando così composizioni uniche nelle aree lounge degli hotel o nei punti vendita.



FLAR	CATEGORY LAMP		TYPE OF LIGHT	
	Table Floor	Tavolo Terra	Diffused light	Luce diffusa





1

1 Flar, blown glass diffuser, FINISHES Honey and Turquoise.
 2 Flar, medium and large, FINISHES Champagne + Honey and Champagne + Turquoise.



2

407 Table lamp, Floor lamp

Flar



Flar medium and large, FINISHES Terra + Turquoise and Terra + Honey.



Table lamp, Floor lamp Flar large, FINISH Champagne + Honey.

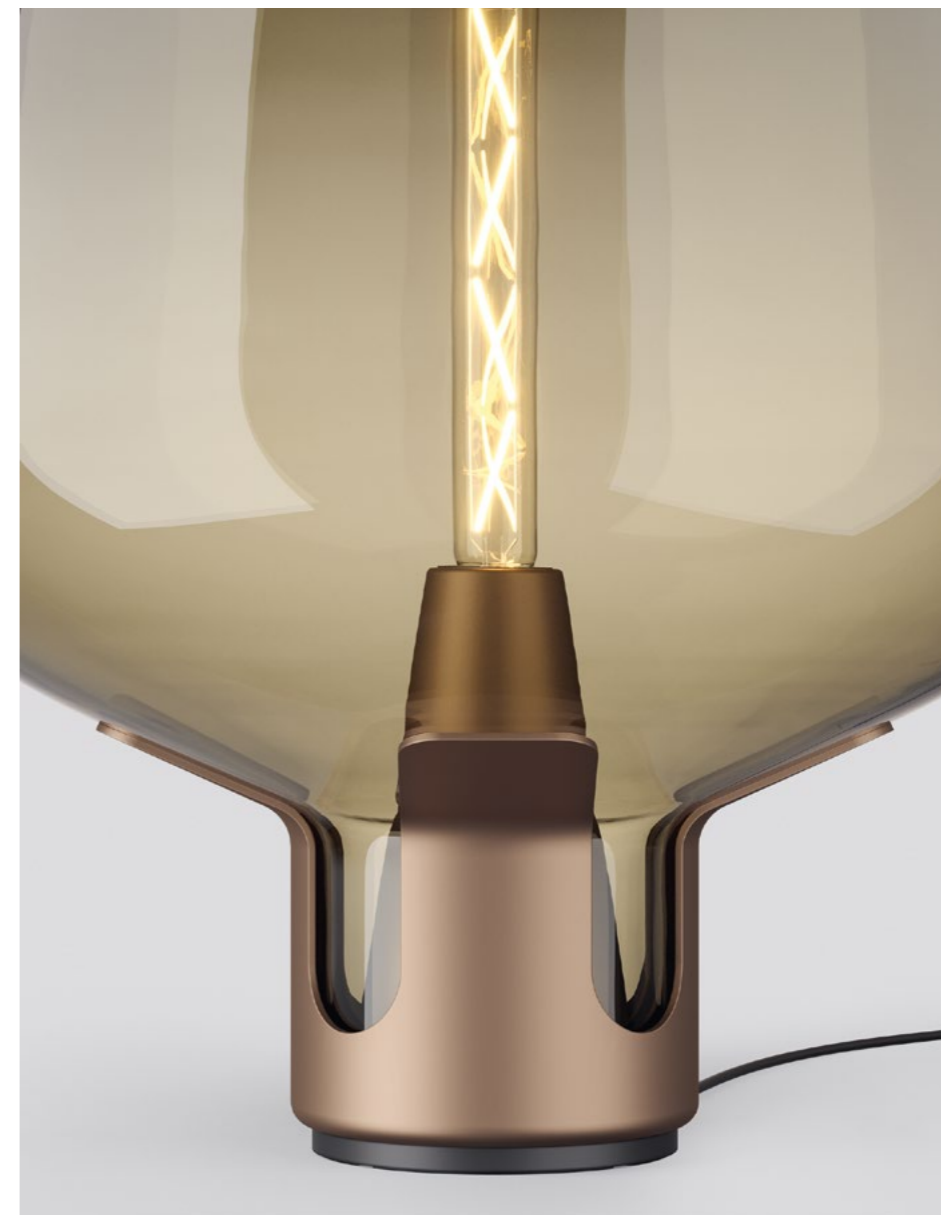

Le nom *Flar* évoque un flamboiement (Flare en anglais) – une flamme intense ou un éclat de lumière. S'inspirant des lanternes tempête traditionnelles qui utilisent des cylindres de verre pour protéger la flamme, *Flar* se compose d'une base en acier découpée au laser 3D qui s'épanouit comme une fleur, portant à un diffuseur en verre soufflé d'une séduisante imperfection disponible en deux tailles, 45 et 60 cm. *Flar* dispose d'un variateur contrôlé par l'interrupteur d'alimentation monté sur câble, permettant à l'utilisateur de moduler l'intensité de la lumière pour créer l'éclairage idéal. Les deux tailles offrent la possibilité de jouer avec les variations pour une composition unique dans un hall d'hôtel ou un magasin. ● FR

Der Name *Flar* erinnert an eine Fackel oder 'flamboiement' im Französischen – ein intensives Aufflammen oder Ausbrechen von Licht. Inspiriert von traditionellen Sturmlaternen, die Glasrohre zum Schutz der Flamme verwenden, besteht *Flar* aus einer 3D-gelasserten Basis aus Stahl, die sich wie eine Blume öffnet und sich zu einem bezaubernden nicht perfekten Diffusor aus mundgeblasenem Glas entwickelt, der in zwei Größen erhältlich ist: 45 und 60 cm. *Flar* ist mit einem Dimmer ausgestattet, der über den am Kabel angebrachten Netzschalter gesteuert wird und es dem Benutzenden ermöglicht, die Intensität des Lichts zu modulieren, um das ideale Beleuchtungsschema zu schaffen. Die beiden Größen bieten die Möglichkeit, mit dem Maßstab zu spielen und eine einzigartige Komposition für eine Hotellounge oder einen Verkaufsraum zu schaffen. ● DE

DE

El nombre *Flar* recoge ecos del término francés «flamboiement», una llamarada o un intenso estallido de luz. Inspirada por las tradicionales lanternas de tormenta que empleaban tubos de vidrio para proteger la llama, *Flar* incluye una base de acero cortada con láser 3D y que se abre como una flor para dar paso a un difusor de vidrio soplado atractivamente imperfecto disponible en dos tamaños, 45 y 60 cm. *Flar* incorpora un regulador que se controla con el interruptor montado en el cable y permite a los usuarios modular la intensidad de la luz para crear su esquema de iluminación ideal. Los dos tamaños ofrecen la oportunidad de jugar con la escala para crear una composición única para el recibidor de un hotel o para una tienda. ● ES

Название *Flar* вызывает в воображении образы вспышки или французское слово «flamboiement», означающее интенсивное пламя или вспышку света. Вдохновленная традиционными штормовыми фонарями, в которых применяются стеклянные трубки для защиты пламени, лампа *Flar* имеет стальное основание 3D, вырезанное лазером, раскрывающееся подобно цветку, ведущее к очаровательно несовершенному диффузору из дутого стекла двух размеров: 45 и 60 см. *Flar* оборудована диммером, управляемым при помощи переключателя питания, монтированного на кабель, для модуляции интенсивности света, позволяя пользователям создавать идеальную схему освещения. Два размера предоставляют возможность играть с масштабом, чтобы создавать уникальные композиции для гостиничного холла или торгового помещения. ● RU

RU

*Flar*这个名字让人联想至耀斑之像或法语的'flamboiement'一词—意为一股烈焰或一阵光耀。受到使用玻璃管保护火焰的传统防风灯启发,*Flar*包含一个3D激光切割钢底座,它像花朵一样张开,形成一个优美迷人的不完美吹制玻璃灯罩,提供45厘米和60厘米两种尺寸。*Flar*具有一个使用安装在线缆上的电源开关进行控制的调光器,使用户能够调节光线强度,以创建理想的照明方案。两种尺寸提供延展发挥的机会,可为酒店休息室或零售空间创建特别致的组合。● ZH

ZH

CATEGORY TABLE LAMP FLOOR LAMP

Flar medium

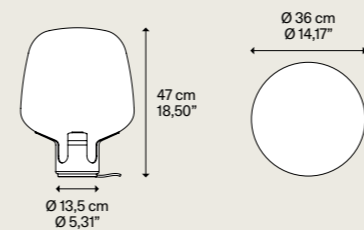

Net weight 6,77 kg
Peso netto 14,92 lbs

Boxes 2
Colli 2

Flar large

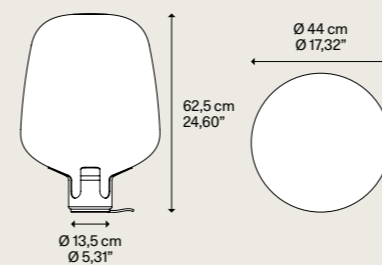

Net weight 9,89 kg
Peso netto 21,80 lbs

Boxes 2
Colli 2

DESIGN Patrick Norguet, 2022

Metal structure
Montatura in metallo

- Champagne Champagne
- Champagne Champagne
- Terra Terra
- Terra Terra

Blown glass diffuser
Diffusore in vetro soffiato

- Honey Miele
- Turquoise Turchese
- Honey Miele
- Turquoise Turchese

Code
Codice

19182 6800U
19182 8600U
19183 6800U
19183 8600U

Light source
Sorgente luminosa

Medium base E26
Tubular LED
1 × 25 W W/L max 25 cm
W/L max 9,84"

Bulb not included
Dimmer on the cord included

Lampadina non inclusa
Dimmer nel filo incluso

IP20 Energy Saving Dim ENEC

Metal structure
Montatura in metallo

- Champagne Champagne
- Champagne Champagne
- Terra Terra
- Terra Terra

Blown glass diffuser
Diffusore in vetro soffiato

- Honey Miele
- Turquoise Turchese
- Honey Miele
- Turquoise Turchese

Code
Codice

19184 6800U
19184 8600U
19185 6800U
19185 8600U

Light source
Sorgente luminosa

Medium base E26
Tubular LED
1 × 25 W W/L max 30 cm
W/L max 11,8"

Bulb not included
Dimmer on the cord included

Lampadina non inclusa
Dimmer nel filo incluso

IP20 Energy Saving Dim ENEC

Flar medium ▾ Table lamp, Floor lamp



Flar large ▾ Table lamp, Floor lamp



Cima, design by Marco Dessí, 2021

Inspired by the function of the jam cleats found in sailing boats, *Cima* – a nautical rope in Italian – is a “suspended” lamp characterised by a ceiling-to-floor rope, a sleek and highly functional design element. A joint that holds the lamp body slides vertically along the rope, while the counterweight allows to manage any excess rope. The simple cylindrical shapes and the black colour of these elements highlight the three brilliant finishes of the rope, vibrant accents to suit any interiors and décor mood.

● Spec sheet p. 423

Ispirata dalla funzione degli strozzascotte delle barche a vela, *Cima* è una lampada “sospesa” caratterizzata da una fune a tutt’altezza, elemento di design elegante e altamente funzionale. Lungo la fune scorre verticalmente un giunto che regge il corpo lampada, mentre il contrappeso permette di gestire l’eventuale fune in eccesso. Le semplici forme cilindriche e il colore nero di questi elementi risaltano le tre finiture brillanti della fune, accenti vibranti per qualsiasi ambiente e mood d’arredo.

CIMA	CATEGORY LAMP		TYPE OF LIGHT	
	Suspension Floor	Sospensione Terra	Symmetrical diffused light Adjustable	Luce simmetrica diffusa Orientabile





Cima, FINISH Silver.



Cima, FINISH Gold.



1



2

1 Cima, FINISH Silver, counterweight/switch button on the power cord.
 2 Cima, FINISH Silver, set the rope at the desired length.

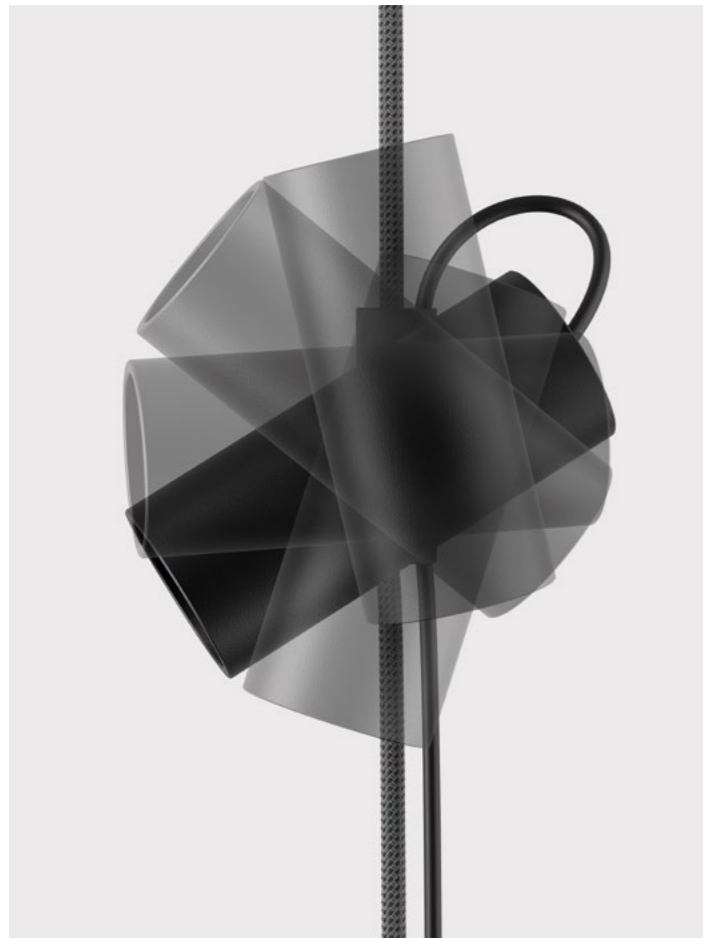

1



2



421

Suspension lamp, Floor lamp

Cima, FINISH Silver.

Cima

1 Cima, easy personalisation of light: change the angle of the lamp body.
 2 Cima, easy personalisation of light: adjust the height of the joint.

S'inspirant de la fonction des taquets de blocage des voiliers, *Cima* – une corde nautique en italien – est une lampe « *suspendue* » caractérisée par une corde plafond-sol, élément de design élégant et fonctionnel. Le raccord qui supporte le corps de la lampe se déplace le long de la corde, tandis que le contrepois permet d'ajuster l'excès de corde. Les formes cylindriques simples et la couleur noire de ces éléments mettent en valeur les trois finitions brillantes de la corde pour s'adapter à tous les intérieurs et à tous les styles de décoration. ● FR

Inspiriert von der Funktion der Klampen, die in Segelbooten auf finden sind, ist *Cima* – das bedeutet Schiffsseil auf Italienisch – eine „hängende Leuchte“, die sich durch ein Decken-Boden-Seil auszeichnet, ein elegantes und hoch funktionales Designelement. Entlang des Seils bewegt sich ein Gelenk, das den Lampenkörper stützt, während das Gegengewicht es ermöglicht, einen eventuellen Seilüberschuss zu justieren. Die schlichten Formen und die schwarze Farbe dieser Elemente unterstreichen die drei brillanten Ausführungen des Seils, vibrierende Akzente, die für jedes Interieur und jede Dèkor Stimmung geeignet sind. ● DE

Inspirada en la función de las cornamusas que se encuentran en los veleros, *Cima* – una cuerda náutica en italiano – es una lámpara “*suspendida*” caracterizada por una cuerda que va del techo al suelo, un elemento de diseño elegante y sumamente funcional. A lo largo de la cuerda se mueve verticalmente una articulación que sujeta el cuerpo de la lámpara, mientras que el contrapeso permite reajustar cualquier exceso de cuerda. Las sencillas formas cilíndricas y el color negro de estos elementos resaltan los tres acabados brillantes de la cuerda, las notas vibrantes de cualquier interior y decoración de ambiente. ● ES

Вдохновленный функцией палубных стопоров, используемых на парусных лодках, светильник *Cima* – «*корабельный канат*» на итальянском – представляет собой подвешенную лампу, с тросом в полную высоту, задуманным как изысканный и высоко функциональный элемент дизайна. Вдоль троса вертикально перемещается шарнир, поддерживающий корпус лампы, а противовес позволяет отрегулировать избыток троса. Простые цилиндрические формы и черный цвет этих элементов подчеркивают три яркие отделки троса, вибрирующие тональности, подходящие для любых интерьеров и стилей. ● RU

受帆船中防滑钉的功能之启发, *Cima* – 意大利语意为航海绳 – 是一款特征显著的“悬浮灯”, 一条全高式绳索便是其优雅且功能强大的设计元素。一块用来举持灯体的接头沿绳索垂直延伸, 而配重件则让您调节管理绳索的任何多余之处。这些元素的简约圆柱形状与黑色突出了绳索的三种光鲜饰面, 令任何室内环境与装饰风尚活力四射。● ZH

Cima » Suspension lamp, Floor lamp

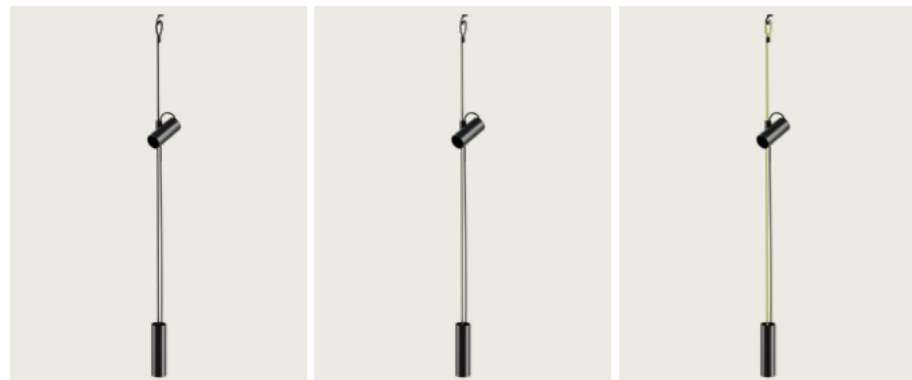

Finishes » Rope

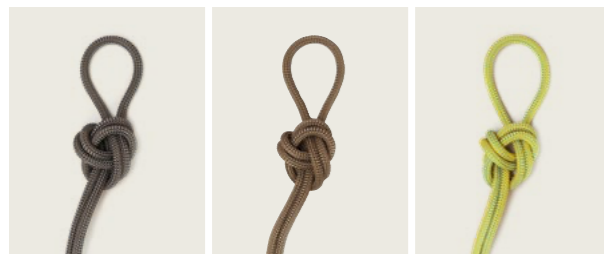

CATEGORY SUSPENSION LAMP FLOOR LAMP

Cima

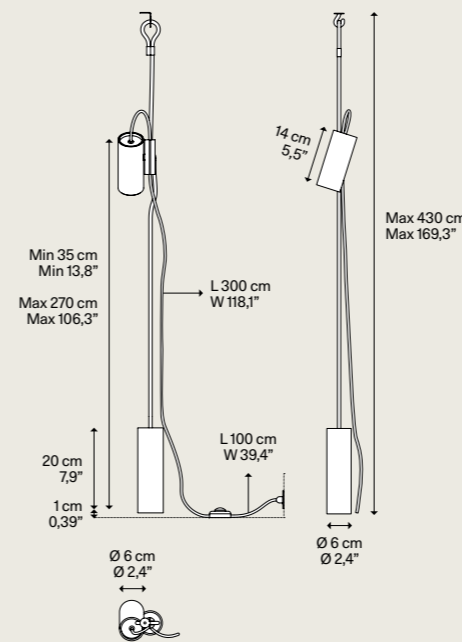

Net weight 1,75 kg / Peso netto 3,86 lbs / Boxes Colli 1

IP20 Energy Saving

DESIGN Marco Dessì, 2021

Metal structure / Montatura in metallo

● Matte Black / Nero Opaco

Rope / Corda

- Silver / Argento
- Gold / Oro
- Yellow / Giallo

Code / Codice

- 17371 4100U
- 17371 5000U
- 17371 5100U

Light source / Sorgente luminosa

GU10 Par 16 LED 1x 10 W W/L max 9 cm / W/L max 3,54"

Bulb not included / Lampadina non inclusa

Description / Descrizione

Additional kit (max 2 spotlights)

Metal structure / Montatura in metallo

● Matte Black / Nero Opaco

Code / Codice

17371K 2000U

Light source / Sorgente luminosa

GU10 Par 16 LED 1x 10 W W/L max 9 cm / W/L max 3,54"

Bulb not included / Lampadina non inclusa

Adjustable light / Luce orientabile

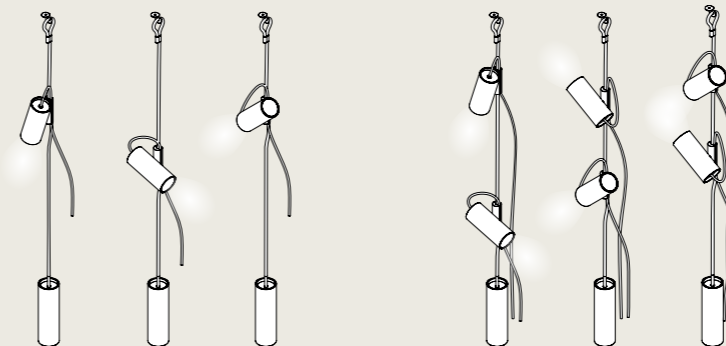

Single canopies

Multiple canopies

Recessed Micro

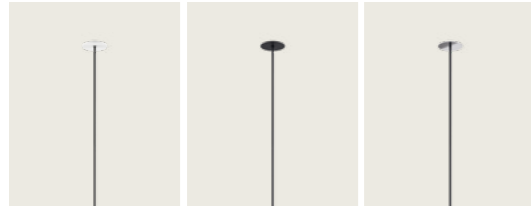

Single Standard



Wall Standard

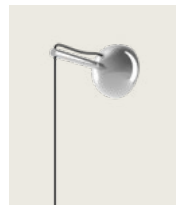

3 Lights Round



5 Lights Round

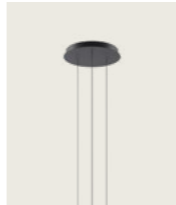

7 Lights Round

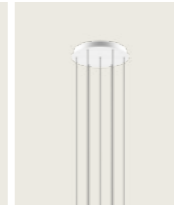

9 Lights Round

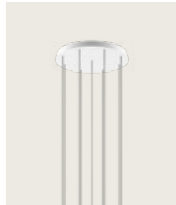

14 Lights Round



24 Lights Round



36 Lights Round

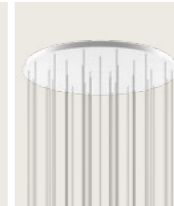

7 Lights Rectangular



14 Lights Rectangular

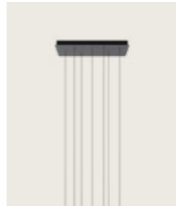

28 Lights Rectangular

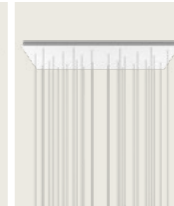

4 Lights Radial



12 Lights Radial

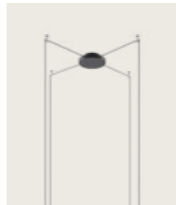

28 Lights Radial

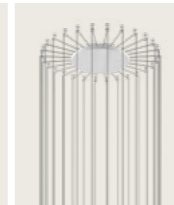

Short Lights Track

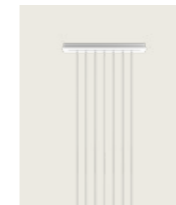

Long Lights Track

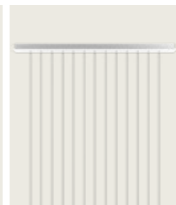

Line Voltage

CATEGORY SINGLE CANOPY

Single

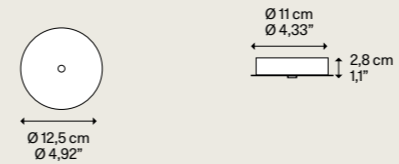

Description Descrizione	Metal structure Struttura in metallo	System Sistema	Code Codice
Single ceiling bracket standard size	<ul style="list-style-type: none"> Matte White - 9010 Bianco Opaco - 9010 Matte Black - 9005 Nero Opaco - 9005 	Single	R03L01 1000U R03L01 2000U
Rosone per lampada singola versione standard	<ul style="list-style-type: none"> Coppery Bronze Bronzo Ramato Chrome Cromo 		R03L01 3500U R03L01 4000U

Net weight 0,40 kg / Peso netto 0,88 lbs | Boxes 1 / Colli 1 | Mounts directly to a 4" Standard J-Box



CATEGORY WALL CANOPY

Wall Standard

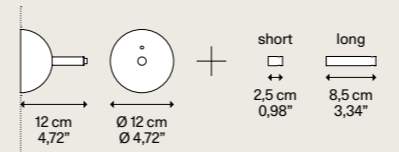

Description Descrizione	Metal structure Montatura in metallo	System Sistema	Code Codice
Wall bracket for suspension modular system	<ul style="list-style-type: none"> Chrome Cromo 	Wall	R12L01 4000U
Supporto a parete per sistema modulare a sospensione			

Net weight 0,40 kg / Peso netto 0,88 lbs | Boxes 1 / Colli 1 | Mounts directly to a 4" Standard J-Box



Cluster suspension lamps

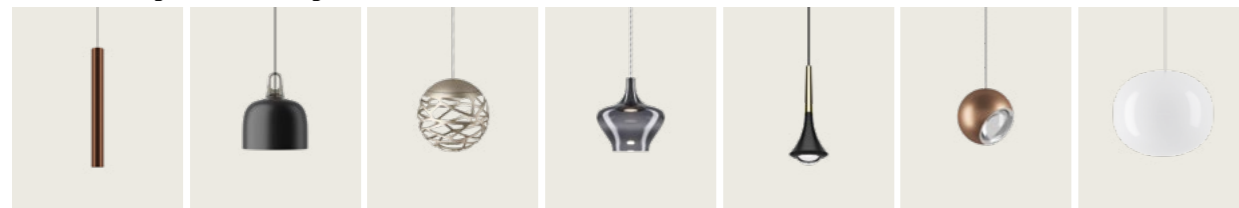

A-Tube P. 232 | JIM P. 192 | Kelly Cluster P. 270 | Nostalgia P. 150 | Rain P. 242 | Spider P. 254 | Volum P. 088

Wall Standard ► Both accessories in the two available lengths are supplied in the box with the wall bracket.

Wall Standard ► Entrambi gli accessori nelle due diverse lunghezze sono inclusi nella confezione con il supporto a parete.

CATEGORY CLUSTER SYSTEM

3 Lights Round

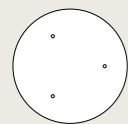

Ø 38 cm
Ø 14,96"

Ø 35 cm
Ø 13,77" 4,2 cm
1,65"

Net weight 3,55 kg Boxes Colli 1 Connectable directly to a 4" Standard J-Box



Description Descrizione	Metal structure Struttura in metallo	System Sistema	Code Codice
Round canopy for 3 suspensions	Matte White - 9010 Bianco Opaco - 9010	Cluster	R04L03 1000U
Rosone circolare per 3 sospensioni	Matte Black - 9005 Nero Opaco - 9005		R04L03 2000U

5 Lights Round

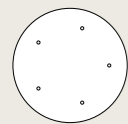

Ø 38 cm
Ø 14,96"

Ø 35 cm
Ø 13,77" 4,2 cm
1,65"

Net weight 3,55 kg Boxes Colli 1 Connectable directly to a 4" Standard J-Box



Description Descrizione	Metal structure Struttura in metallo	System Sistema	Code Codice
Round canopy for 5 suspensions	Matte White - 9010 Bianco Opaco - 9010	Cluster	R04L05 1000U
Rosone circolare per 5 sospensioni	Matte Black - 9005 Nero Opaco - 9005		R04L05 2000U

7 Lights Round

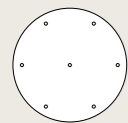

Ø 38 cm
Ø 14,96"

Ø 35 cm
Ø 13,77" 4,2 cm
1,65"

Net weight 3,55 kg Boxes Colli 1 Connectable directly to a 4" Standard J-Box



Description Descrizione	Metal structure Struttura in metallo	System Sistema	Code Codice
Round canopy for 7 suspensions	Matte White - 9010 Bianco Opaco - 9010	Cluster	R04L07 1000U
Rosone circolare per 7 sospensioni	Matte Black - 9005 Nero Opaco - 9005		R04L07 2000U

CATEGORY CLUSTER SYSTEM

9 Lights Round

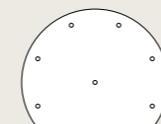

Ø 50 cm
Ø 19,68"

Ø 47 cm
Ø 18,50" 4,2 cm
1,65"

Net weight 5,84 kg Boxes Colli 1 Connectable directly to a 4" Standard J-Box

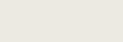

Description Descrizione	Metal structure Struttura in metallo	System Sistema	Code Codice
Round canopy for 9 suspensions	Matte White - 9010 Bianco Opaco - 9010	Cluster	R04L09 1000U
Rosone circolare per 9 sospensioni	Matte Black - 9005 Nero Opaco - 9005		R04L09 2000U

14 Lights Round

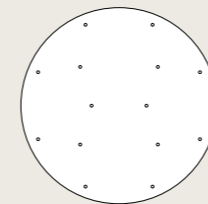

Ø 74 cm
Ø 29,13"

Ø 70 cm
Ø 27,55" 4,2 cm
1,65"

Net weight 14,14 kg Boxes Colli 1 Connectable directly to a 4" Standard J-Box



Description Descrizione	Metal structure Struttura in metallo	System Sistema	Code Codice
Round canopy for 14 suspensions	Matte White - 9010 Bianco Opaco - 9010	Cluster	R04L14 1000U
Rosone circolare per 14 sospensioni	Matte Black - 9005 Nero Opaco - 9005		R04L14 2000U

CATEGORY CLUSTER SYSTEM

24 Lights Round

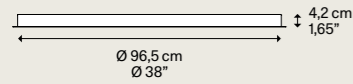
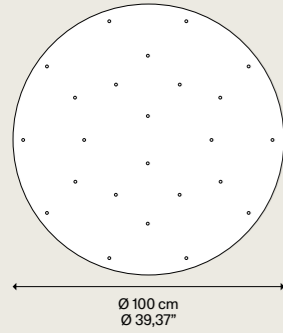

Net weight 23,50 kg / 51,80 lbs
Boxes Colli 1
Connectable directly to a 4" Standard J-Box



Description Descrizione	Metal structure Struttura in metallo	System Sistema	Code Codice
Round canopy for 24 suspensions	Matte White - 9010 Bianco Opaco - 9010	Cluster	R04L24 1000U
Rosone circolare per 24 sospensioni	Matte Black - 9005 Nero Opaco - 9005		R04L24 2000U

36 Lights Round

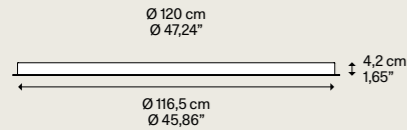
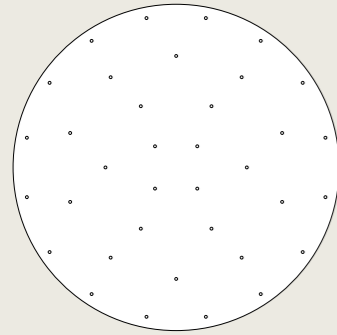

Net weight 32,70 kg / 72,09 lbs
Boxes Colli 1
Connectable directly to a 4" Standard J-Box



Description Descrizione	Metal structure Struttura in metallo	System Sistema	Code Codice
Round canopy for 36 suspensions	Matte White - 9010 Bianco Opaco - 9010	Cluster	R04L36 1000U
Rosone circolare per 36 sospensioni	Matte Black - 9005 Nero Opaco - 9005		R04L36 2000U

CATEGORY CLUSTER SYSTEM

7 Lights Rectangular

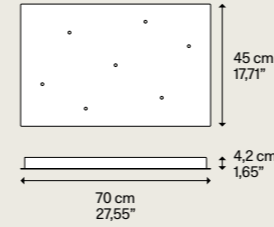

Net weight 9,89 kg / 21,80 lbs
Boxes Colli 1
Connectable directly to a 4" Standard J-Box



Description Descrizione	Metal structure Struttura in metallo	System Sistema	Code Codice
Rectangular canopy for 7 suspensions	Matte White - 9010 Bianco Opaco - 9010	Cluster	R05L07 1000U
Rosone rettangolare per 7 sospensioni	Matte Black - 9005 Nero Opaco - 9005		R05L07 2000U

14 Lights Rectangular

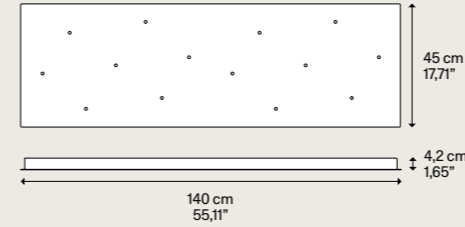

Net weight 17,10 kg / 37,80 lbs
Boxes Colli 1
Connectable directly to a 4" Standard J-Box



Description Descrizione	Metal structure Struttura in metallo	System Sistema	Code Codice
Rectangular canopy for 14 suspensions	Matte White - 9010 Bianco Opaco - 9010	Cluster	R05L14 1000U
Rosone rettangolare per 14 sospensioni	Matte Black - 9005 Nero Opaco - 9005		R05L14 2000U

28 Lights Rectangular

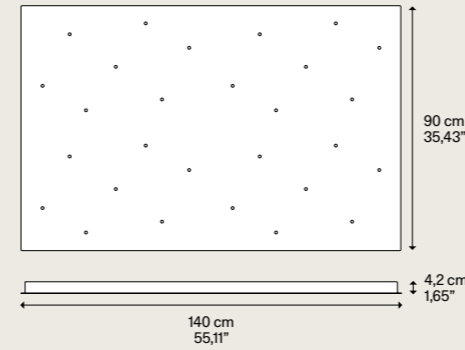

Net weight 31,10 kg / 68,56 lbs
Boxes Colli 1
Connectable directly to a 4" Standard J-Box



Description Descrizione	Metal structure Struttura in metallo	System Sistema	Code Codice
Rectangular canopy for 28 suspensions	Matte White - 9010 Bianco Opaco - 9010	Cluster	R05L28 1000U
Rosone rettangolare per 28 sospensioni	Matte Black - 9005 Nero Opaco - 9005		R05L28 2000U

CATEGORY RADIAL SYSTEM

4 Lights Radial



Ø 16,5 cm
Ø 6,49"

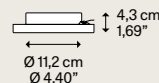

4,3 cm
1,69"
Ø 11,2 cm
Ø 4,40"

Net weight 0,35 kg / 0,13 lbs
Boxes Colli 1
Mounts directly to a 4" Standard J-Box



Description Descrizione	Metal structure Struttura in metallo	System Sistema	Code Codice
Radial canopy max 4 suspension Radial Swag Kit not included	Matte White - 9010 Bianco Opaco - 9010	Radial	R10L04 1000U
Rosone radiale max 4 sospensioni Radial Swag Kit non incluso	Matte Black - 9005 Nero Opaco - 9005		R10L04 2000U

12 Lights Radial



Ø 25 cm
Ø 9,84"

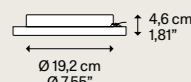

4,6 cm
1,81"
Ø 19,2 cm
Ø 7,55"

Net weight 1,05 kg / 2,31 lbs
Boxes Colli 1
Mounts directly to a 4" Standard J-Box



Description Descrizione	Metal structure Struttura in metallo	System Sistema	Code Codice
Radial canopy max 12 suspension Radial Swag Kit not included	Matte White - 9010 Bianco Opaco - 9010	Radial	R10L12 1000U
Rosone radiale max 12 sospensioni Radial Swag Kit non incluso	Matte Black - 9005 Nero Opaco - 9005		R10L12 2000U

28 Lights Radial

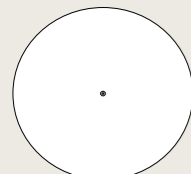

Ø 36 cm
Ø 14,17"

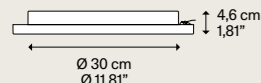

4,6 cm
1,81"
Ø 30 cm
Ø 11,81"

Net weight 3,35 kg / 7,38 lbs
Boxes Colli 1
Mounts directly to a 4" Standard J-Box



Description Descrizione	Metal structure Struttura in metallo	System Sistema	Code Codice
Radial canopy max 28 suspension Radial Swag Kit not included	Matte White - 9010 Bianco Opaco - 9010	Radial	R10L28 1000U
Rosone radiale max 28 sospensioni Radial Swag Kit non incluso	Matte Black - 9005 Nero Opaco - 9005		R10L28 2000U

Swag Kit for Radial Canopy



Ø 2 cm
Ø 0,78"



3 cm
1,18"

Net weight 0,02 kg / 0,04 lbs
Boxes Colli 1



Description Descrizione	Metal structure Struttura in metallo	System Sistema	Code Codice
Wall and ceiling anchor for Radial System power cable / Max Ø 7 mm - 0,27" / Max capacity 5 kg - 11,02 lbs	Clear Trasparente	Radial	999A4 00
Cilindro di decentramento per Sistema Radiale cavo elettrico / Max Ø 7 mm - 0,27" / Portata max 5 kg - 11,02 lbs			

CATEGORY TRACK SYSTEM

Short Lights Track

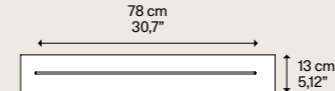

78 cm
30,7"
13 cm
5,12"

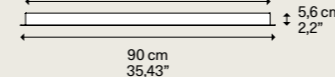

87 cm
34,25"
5,6 cm
2,2"

Net weight 7,33 kg / 16,16 lbs
Boxes Colli 1
Connectable directly to a 4" Standard J-Box



Description Descrizione	Metal structure Struttura in metallo	System Sistema	Code Codice
Multiple linear track standard version max 7 suspensions	Matte White - 9010 Bianco Opaco - 9010	Track	R08L07 1000U
Binario lineare multiplo versione standard max 7 sospensioni	Matte Black - 9005 Nero Opaco - 9005		R08L07 2000U

Long Lights Track

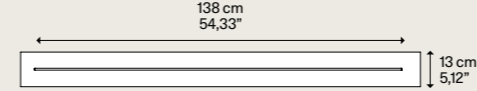

138 cm
54,33"
13 cm
5,12"



147 cm
57,87"
5,6 cm
2,2"

Net weight 11,85 kg / 26,12 lbs
Boxes Colli 1
Connectable directly to a 4" Standard J-Box



Description Descrizione	Metal structure Struttura in metallo	System Sistema	Code Codice
Multiple linear track standard version max 11 suspensions	Matte White - 9010 Bianco Opaco - 9010	Track	R08L11 1000U
Binario lineare multiplo versione standard max 11 sospensioni	Matte Black - 9005 Nero Opaco - 9005		R08L11 2000U

Suspension aligned, maximum quantity
Sospensione allineata, quantità massima



Staggered suspension, maximum quantity
Sospensione sfalsata, quantità massima



Short Lights Track		Long Lights Track		Short Lights Track		Long Lights Track	
Max 7	A-Tube	Max 11	A-Tube	Max 7	A-Tube	Max 11	A-Tube
Max 4	JIM cylinder	Max 8	JIM cylinder	Max 4	JIM cylinder	Max 8	JIM cylinder
Max 3	JIM cone	Max 5	JIM cone	Max 3	JIM cone	Max 5	JIM cone
Max 3	JIM bell	Max 5	JIM bell	Max 3	JIM bell	Max 5	JIM bell
Max 4	Kelly Cluster	Max 8	Kelly Cluster	Max 4	Kelly Cluster	Max 8	Kelly Cluster
Max 7	Nostalgia small	Max 11	Nostalgia small	Max 7	Nostalgia small	Max 11	Nostalgia small
Max 4	Nostalgia medium	Max 7	Nostalgia medium	Max 4	Nostalgia medium	Max 7	Nostalgia medium
Max 3	Nostalgia large	Max 5	Nostalgia large	Max 3	Nostalgia large	Max 5	Nostalgia large
Max 7	Rain	Max 11	Rain	Max 7	Rain	Max 11	Rain
Max 7	Spider	Max 11	Spider	Max 7	Spider	Max 11	Spider
Max 6	Volum 14	Max 10	Volum 14	Max 6	Volum 14	Max 10	Volum 14
Max 4	Volum 22	Max 7	Volum 22	Max 4	Volum 22	Max 7	Volum 22
Max 3	Volum 29	Max 5	Volum 29	Max 3	Volum 29	Max 5	Volum 29

CATEGORY WALL CEILING

Mud-Kit

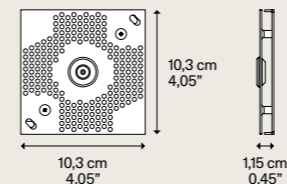

Description Descrizione	Code Codice
Both Wall/Ceiling use Usa a Parete/Soffitto	99999 9900U



Low Voltage

CATEGORY RECESSED CANOPY

Low Voltage Recessed Micro

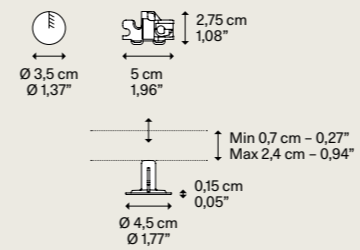

Description
Descrizione

Recessed bracket for single lamp max capacity 3,5 kg – 7,71 lbs

Rosone da incasso per lampada singola portata max 3,5 kg – 7,71 lbs

Methacrylate structure
Struttura in metacrilato

Matte White – 9010
Bianco Opaco – 9010

Matte Black – 9005
Nero Opaco – 9005

Chrome
Cromo

System
Sistema

Recessed

Code
Codice

R01L01 1000U

R01L01 2000U

R01L01 4000U

Net weight 0,015 kg
Peso netto 0,033 lbs

Pack 1
Colli



► Suitable for ceilings up to 2,4 cm – 0,94" thickness.

► Adatta per soffitti fino a 2,4 cm – 0,94" di spessore.

CATEGORY SINGLE CANOPY

Single

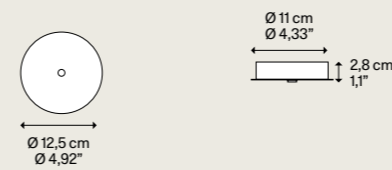

Description
Descrizione

Single ceiling bracket standard size
Driver included

Rosone per lampada singola versione standard
Driver incluso

Methacrylate structure
Struttura in metacrilato

Matte White – 9010
Bianco Opaco – 9010

Matte Black – 9005
Nero Opaco – 9005

Chrome
Cromo

System
Sistema

Single

Code
Codice

R03L01 1000MU

R03L01 2000MU

R03L01 4000MU

Net weight 0,40 kg
Peso netto 0,88 lbs

Boxes 1
Colli

Mounts directly to a 4" Standard J-Box



Cluster suspension lamps



A-Tube Nano p. 204 A-Tube Nano Duo p. 222 IVY I p. 176 Jefferson p. 166 Random p. 110 Random Solo p. 130

CATEGORY CLUSTER SYSTEM

3 Lights Round

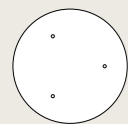

Ø 38 cm
Ø 14,96"

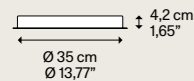

Net weight 3,55 kg
Peso netto 7,82 lbs

Boxes Colli 1

Connectable directly to a 4" Standard J-Box



Description Descrizione	Metal structure Struttura in metallo	System Sistema	Code Codice
Round canopy for 3 suspensions	Matte White - 9010 Bianco Opaco - 9010	Cluster	R04L03 1000MU
Rosone circolare per 3 sospensioni	Matte Black - 9005 Nero Opaco - 9005		R04L03 2000MU

5 Lights Round

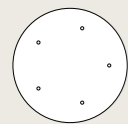

Ø 38 cm
Ø 14,96"

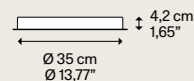

Net weight 3,55 kg
Peso netto 7,82 lbs

Boxes Colli 1

Connectable directly to a 4" Standard J-Box



Description Descrizione	Metal structure Struttura in metallo	System Sistema	Code Codice
Round canopy for 5 suspensions	Matte White - 9010 Bianco Opaco - 9010	Cluster	R04L05 1000MU
Rosone circolare per 5 sospensioni	Matte Black - 9005 Nero Opaco - 9005		R04L05 2000MU

7 Lights Round

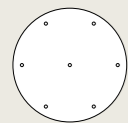

Ø 38 cm
Ø 14,96"

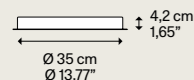

Net weight 3,55 kg
Peso netto 7,82 lbs

Boxes Colli 1

Connectable directly to a 4" Standard J-Box



Description Descrizione	Metal structure Struttura in metallo	System Sistema	Code Codice
Round canopy for 7 suspensions	Matte White - 9010 Bianco Opaco - 9010	Cluster	R04L07 1000MU
Rosone circolare per 7 sospensioni	Matte Black - 9005 Nero Opaco - 9005		R04L07 2000MU

CATEGORY CLUSTER SYSTEM

9 Lights Round

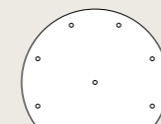

Ø 50 cm
Ø 19,68"

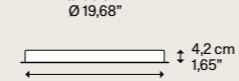

Net weight 5,84 kg
Peso netto 12,87 lbs

Boxes Colli 1

Connectable directly to a 4" Standard J-Box

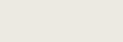

Description Descrizione	Metal structure Struttura in metallo	System Sistema	Code Codice
Round canopy for 9 suspensions	Matte White - 9010 Bianco Opaco - 9010	Cluster	R04L09 1000MU
Rosone circolare per 9 sospensioni	Matte Black - 9005 Nero Opaco - 9005		R04L09 2000MU

14 Lights Round

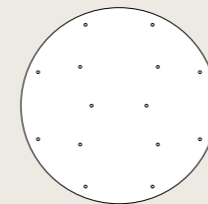

Ø 74 cm
Ø 29,13"

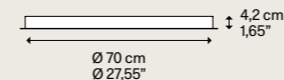

Net weight 14,14 kg
Peso netto 31,17 lbs

Boxes Colli 1

Connectable directly to a 4" Standard J-Box



Description Descrizione	Metal structure Struttura in metallo	System Sistema	Code Codice
Round canopy for 14 suspensions	Matte White - 9010 Bianco Opaco - 9010	Cluster	R04L14 1000MU
Rosone circolare per 14 sospensioni	Matte Black - 9005 Nero Opaco - 9005		R04L14 2000MU

CATEGORY CLUSTER SYSTEM

24 Lights Round

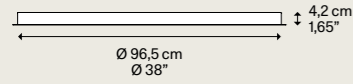
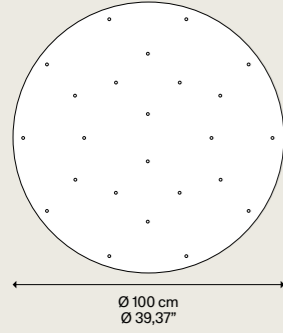

Net weight 23,50 kg / 51,80 lbs
Boxes Colli 1
Connectable directly to a 4" Standard J-Box



Description Descrizione	Metal structure Struttura in metallo	System Sistema	Code Codice
Round canopy for 24 suspensions	Matte White - 9010 Bianco Opaco - 9010	Cluster	R04L24 1000MU
Rosone circolare per 24 sospensioni	Matte Black - 9005 Nero Opaco - 9005		R04L24 2000MU

36 Lights Round

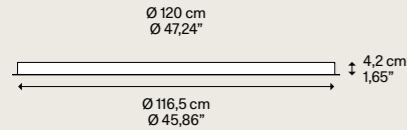
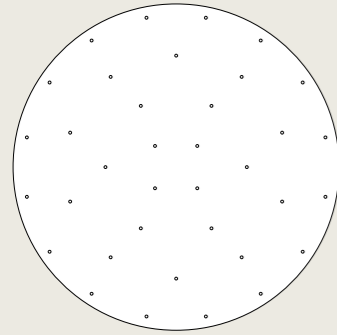

Net weight 32,70 kg / 72,09 lbs
Boxes Colli 1
Connectable directly to a 4" Standard J-Box



Description Descrizione	Metal structure Struttura in metallo	System Sistema	Code Codice
Round canopy for 36 suspensions	Matte White - 9010 Bianco Opaco - 9010	Cluster	R04L36 1000MU
Rosone circolare per 36 sospensioni	Matte Black - 9005 Nero Opaco - 9005		R04L36 2000MU

CATEGORY CLUSTER SYSTEM

7 Lights Rectangular

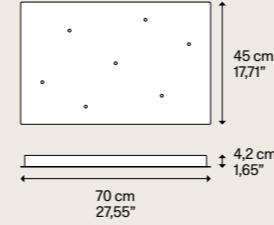

Net weight 9,89 kg / 21,80 lbs
Boxes Colli 1
Connectable directly to a 4" Standard J-Box



Description Descrizione	Metal structure Struttura in metallo	System Sistema	Code Codice
Rectangular canopy for 7 suspensions	Matte White - 9010 Bianco Opaco - 9010	Cluster	R05L07 1000MU
Rosone rettangolare per 7 sospensioni	Matte Black - 9005 Nero Opaco - 9005		R05L07 2000MU

14 Lights Rectangular

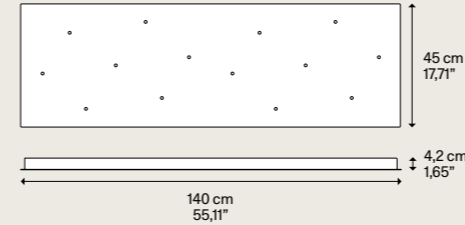

Net weight 17,10 kg / 37,80 lbs
Boxes Colli 1
Connectable directly to a 4" Standard J-Box



Description Descrizione	Metal structure Struttura in metallo	System Sistema	Code Codice
Rectangular canopy for 14 suspensions	Matte White - 9010 Bianco Opaco - 9010	Cluster	R05L14 1000MU
Rosone rettangolare per 14 sospensioni	Matte Black - 9005 Nero Opaco - 9005		R05L14 2000MU

28 Lights Rectangular

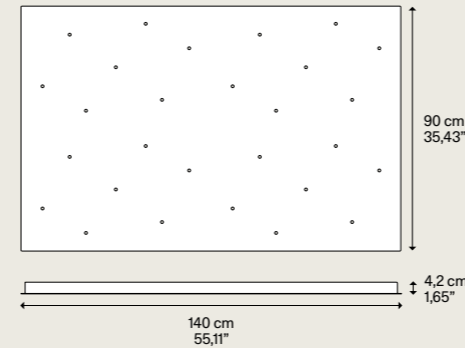

Net weight 31,10 kg / 68,56 lbs
Boxes Colli 1
Connectable directly to a 4" Standard J-Box



Description Descrizione	Metal structure Struttura in metallo	System Sistema	Code Codice
Rectangular canopy for 28 suspensions	Matte White - 9010 Bianco Opaco - 9010	Cluster	R05L28 1000MU
Rosone rettangolare per 28 sospensioni	Matte Black - 9005 Nero Opaco - 9005		R05L28 2000MU

CATEGORY RADIAL SYSTEM

4 Lights Radial



Ø 16,5 cm
Ø 6,49"

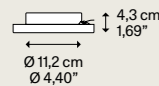

Net weight 0,35 kg / 0,13 lbs
Boxes Colli 1
Mounts directly to a 4" Standard J-Box



Description Descrizione	Metal structure Struttura in metallo	System Sistema	Code Codice
Radial canopy max 4 suspension Radial Swag Kit not included	Matte White - 9010 Bianco Opaco - 9010	Radial	R10L04 1000MU
Rosone radiale max 4 sospensioni Radial Swag Kit non incluso	Matte Black - 9005 Nero Opaco - 9005		R10L04 2000MU

12 Lights Radial



Ø 25 cm
Ø 9,84"

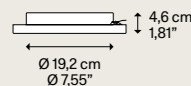

Net weight 1,05 kg / 2,31 lbs
Boxes Colli 1
Mounts directly to a 4" Standard J-Box



Description Descrizione	Metal structure Struttura in metallo	System Sistema	Code Codice
Radial canopy max 12 suspension Radial Swag Kit not included	Matte White - 9010 Bianco Opaco - 9010	Radial	R10L12 1000MU
Rosone radiale max 12 sospensioni Radial Swag Kit non incluso	Matte Black - 9005 Nero Opaco - 9005		R10L12 2000MU

28 Lights Radial

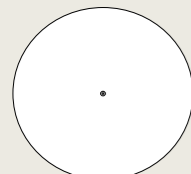

Ø 36 cm
Ø 14,17"

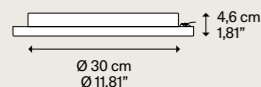

Net weight 3,35 kg / 7,38 lbs
Boxes Colli 1
Mounts directly to a 4" Standard J-Box



Description Descrizione	Metal structure Struttura in metallo	System Sistema	Code Codice
Radial canopy max 28 suspension Radial Swag Kit not included	Matte White - 9010 Bianco Opaco - 9010	Radial	R10L28 1000MU
Rosone radiale max 28 sospensioni Radial Swag Kit non incluso	Matte Black - 9005 Nero Opaco - 9005		R10L28 2000MU

Swag Kit for Radial Canopy



Net weight 0,02 kg / 0,04 lbs
Boxes Colli 1



Description Descrizione	Metal structure Struttura in metallo	System Sistema	Code Codice
Wall and ceiling anchor for Radial System power cable / Max Ø 7 mm - 0,27" / Max capacity 5 kg - 11,02 lbs	Clear Trasparente	Radial	999A4 00
Cilindro di decentramento per Sistema Radiale cavo elettrico / Max Ø 7 mm - 0,27" / Portata max 5 kg - 11,02 lbs			

CATEGORY TRACK SYSTEM

Short Lights Track

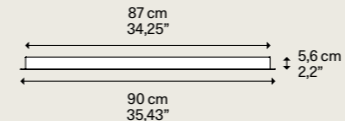
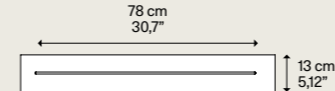

Net weight 7,33 kg / 16,16 lbs
Boxes Colli 1
Connectable directly to a 4" Standard J-Box



Description Descrizione	Metal structure Struttura in metallo	System Sistema	Code Codice
Multiple linear track standard version max 7 suspensions	Matte White - 9010 Bianco Opaco - 9010	Track	R08L07 1000MU
Binario lineare multiplo versione standard max 7 sospensioni	Matte Black - 9005 Nero Opaco - 9005		R08L07 2000MU

Long Lights Track

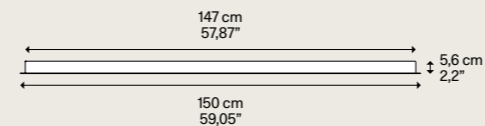
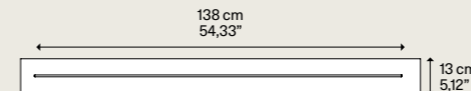

Net weight 11,85 kg / 26,12 lbs
Boxes Colli 1
Connectable directly to a 4" Standard J-Box



Description Descrizione	Metal structure Struttura in metallo	System Sistema	Code Codice
Multiple linear track standard version max 11 suspensions	Matte White - 9010 Bianco Opaco - 9010	Track	R08L11 1000MU
Binario lineare multiplo versione standard max 11 sospensioni	Matte Black - 9005 Nero Opaco - 9005		R08L11 2000MU

Suspension aligned, maximum quantity
Sospensione allineata, quantità massima



Staggered suspension, maximum quantity
Sospensione sfalsata, quantità massima



Short Lights Track		Long Lights Track		Short Lights Track		Long Lights Track	
Max 6	A-Tube Nano	Max 6	A-Tube Nano	Max 6	A-Tube Nano	Max 6	A-Tube Nano
Max 6	A-Tube Nano Duo	Max 6	A-Tube Nano Duo	Max 6	A-Tube Nano Duo	Max 6	A-Tube Nano Duo
Max 7	IVY I	Max 7	IVY I	Max 7	IVY I	Max 7	IVY I
Max 6	Jefferson	Max 6	Jefferson	Max 6	Jefferson	Max 6	Jefferson
Max 5	Random	Max 5	Random	Max 5	Random	Max 5	Random
Max 7	Random Solo 10	Max 7	Random Solo 10	Max 7	Random Solo 10	Max 7	Random Solo 10
Max 7	Random Solo 12	Max 7	Random Solo 12	Max 7	Random Solo 12	Max 7	Random Solo 12
Max 7	Random Solo 14	Max 7	Random Solo 14	Max 7	Random Solo 14	Max 7	Random Solo 14
Max 7	Random Solo 18	Max 7	Random Solo 18	Max 7	Random Solo 18	Max 7	Random Solo 18
Max 7	Random Solo 23	Max 7	Random Solo 23	Max 7	Random Solo 23	Max 7	Random Solo 23
Max 6	Random Solo 28	Max 6	Random Solo 28	Max 6	Random Solo 28	Max 6	Random Solo 28

CATEGORY WALL CEILING

Mud-Kit

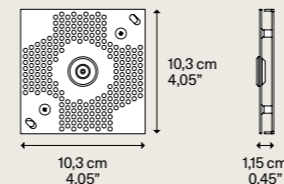

Description Descrizione	Code Codice
Both Wall / Ceiling use Usa a Parete / Soffitto	99999 9900U











Light sources power

Potenza fonti luminose

PAGE	SPEC SHEET	PRODUCT NAME	CATEGORY	TOTAL POWER DRAW	LED QUANTITY & POWER	LED TOTAL POWER
P. 348	P. 354	A-Tube Nano	Cluster suspension lamp	4 w	1 × 3 w	3 w
P. 204	P. 220	A-Tube Nano Duo	Cluster suspension lamp	4 w	2 × 1 w	2 w
P. 312	P. 317	Aile	Wall lamp	18 w	2 × 9 w	18 w
P. 380	P. 385	Blow	Table lamp	4,5 w	1 × 4,5 w	4,5 w
P. 348	P. 354	Bugia Single	Ceiling lamp	17 w	1 × 17 w	17 w
P. 348	P. 354	Bugia Double	Ceiling lamp	34 w	2 × 17 w	34 w
P. 348	P. 354	Bugia Triple	Ceiling lamp	51 w	3 × 17 w	51 w
P. 348	P. 354	Bugia Mega	Ceiling lamp	51 w	3 × 17 w	51 w
P. 074	P. 087	Cono di Luce	Cluster suspension lamp	11 w	1 × 7 w	7 w
P. 074	P. 087	Cono di Luce	Table lamp	7,5 w	1 × 7,5 w	7,5 w
P. 394	P. 403	Croma	Floor lamp	42 w	1 × 42 w	42 w
P. 386	P. 393	Easy Peasy	Cordless table lamp	5 w	1 × 5 w	5 w
P. 034	P. 045	Elara	Suspension lamp	33 w	18 w + 9 w	27 w
P. 370	P. 379	Hover	Floor lamp, Table lamp	6,5 w	1 × 6,5 w	6,5 w
P. 176	P. 190	IVY	Cluster suspension lamp, Suspension lamp, Central cluster suspension lamp	4 w	1 × 3 w	3 w
P. 166	P. 175	Jefferson	Cluster suspension lamp	4 w	1 × 3 w	3 w
P. 192	P. 202	JIM	Cluster suspension lamp, Suspension lamp	25 w		
P. 270	P. 279	Kelly Cluster	Cluster suspension lamp	9 w	1 × 7 w	7 w
P. 060	P. 071	Kelly	Wall lamp	17 w	1 × 17 w	17 w
P. 362	P. 367	Laser	Wall lamp, Ceiling lamp	17 w	1 × 17 w	17 w
P. 292	P. 309	Nautilus	Wall lamp	30 w	2 × 15 w	30 w
P. 292	P. 310	Nautilus Mini	Wall lamp	12 w	1 × 12 w	12 w
P. 292	P. 310	Nautilus	Ceiling lamp	15 w	1 × 15 w	15 w
P. 292	P. 311	Nautilus Spot	Ceiling lamp	10 w	1 × 10 w	10 w
P. 150	P. 164	Nostalgia	Cluster suspension lamp	9 w	1 × 7 w	7 w
P. 356	P. 361	Pin-Up	Wall lamp, Ceiling lamp	9 w	1 × 9 w	9 w
P. 328	P. 333	Puzzle Single Square	Wall lamp, Ceiling lamp	17 w	1 × 17 w	17 w
P. 328	P. 333	Puzzle Double Square	Wall lamp, Ceiling lamp	34 w	2 × 17 w	34 w
P. 328	P. 333	Puzzle Square & Rectangle	Wall lamp, Ceiling lamp	34 w	2 × 17 w	34 w
P. 318	P. 327	Puzzle Round Single	Wall lamp, Ceiling lamp	17 w	1 × 17 w	17 w
P. 318	P. 327	Puzzle Round Double	Wall lamp, Ceiling lamp	34 w	2 × 17 w	34 w
P. 334	P. 345	Puzzle Mega Round Small	Wall lamp, Ceiling lamp	51 w	3 × 17 w	51 w
P. 334	P. 345	Puzzle Mega Round Large	Wall lamp, Ceiling lamp	68 w	4 × 17 w	68 w
P. 334	P. 346	Puzzle Mega Square Small	Wall lamp, Ceiling lamp	51 w	3 × 17 w	51 w
P. 334	P. 346	Puzzle Mega Square Large	Wall lamp, Ceiling lamp	68 w	4 × 17 w	68 w
P. 242	P. 253	Rain	Cluster suspension lamp	9 w	1 × 7 w	7 w
P. 110	P. 129	Random	Cluster suspension lamp	4 w	3 × 1 w	3 w
P. 020	P. 030	Random Cloud 7 Lights	Suspension lamp	28 w	7 × 3 w	21 w
P. 020	P. 031	Random Cloud 14 Lights	Suspension lamp	56 w	14 × 3 w	42 w
P. 020	P. 032	Random Cloud 19 Lights	Suspension lamp	76 w	19 × 3 w	57 w
P. 020	P. 033	Random Cloud 23 Lights	Suspension lamp	92 w	23 × 3 w	69 w
P. 130	P. 147	Random Solo 10	Cluster suspension lamp	3 w	1 × 1 w	1 w
P. 130	P. 147	Random Solo 12	Cluster suspension lamp	3 w	1 × 1 w	1 w
P. 130	P. 148	Random Solo 14	Cluster suspension lamp	3 w	1 × 1 w	1 w
P. 130	P. 148	Random Solo 18	Cluster suspension lamp	3 w	1 × 1 w	1 w
P. 130	P. 149	Random Solo 23	Cluster suspension lamp	4 w	1 × 3 w	3 w
P. 130	P. 149	Random Solo 28	Cluster suspension lamp	4 w	1 × 3 w	3 w
P. 046	P. 057	Sky-Fall, Sky-Fall Round	Suspension lamp	20 w	2 × 8,5 w	17 w
P. 254	P. 269	Spider	Cluster suspension lamp	10 w	1 × 10 w	10 w
P. 254	P. 269	Spider	Ceiling lamp	10 w	1 × 10 w	10 w
P. 282	P. 291	Tidal	Ceiling lamp	38 w	25 w + 9 w	34 w
P. 282	P. 291	Tidal	Ceiling lamp	29 w	19 w + 7 w	26 w
P. 282	P. 291	Tidal	Ceiling lamp	27 w	18 w + 6 w	24 w
P. 282	P. 291	Tidal	Ceiling lamp	23 w	15 w + 5,5 w	20,5 w

Legenda

CATEGORY	TYPE OF LIGHT	
	Cluster suspension	● EN
	Sospensioni cluster	● IT
	Cluster suspension	● FR
	Pendel-Cluster	● DE
	Suspensión Cluster	● ES
	Подвесной Cluster	● RU
	Cluster 悬吊灯	● ZH
	Suspension	● EN
	Sospensioni	● IT
	Suspension	● FR
	Pendel	● DE
	Suspensión	● ES
	Подвесной	● RU
	悬吊灯	● ZH
	Wall	● EN
	Parete	● IT
	Applique	● FR
	Wand	● DE
	Pared	● ES
	Настенный	● RU
	壁灯	● ZH
	Ceiling	● EN
	Soffitto	● IT
	Plafonnier	● FR
	Decke	● DE
	Techo	● ES
	Потолочный	● RU
	吸顶灯	● ZH
	Table	● EN
	Tavolo	● IT
	Table	● FR
	Tisch	● DE
	Sobremesa	● ES
	Настольный	● RU
	台灯	● ZH
	Floor	● EN
	Terra	● IT
	Lampadaire	● FR
	Boden	● DE
	Pie	● ES
	Напольный	● RU
	落地灯	● ZH
	Diffused light	● EN
	Luce diffusa	● IT
	Lumière diffuse	● FR
	Diffuses Licht	● DE
	Luz difusa	● ES
	Рассеянный свет	● RU
	漫射光	● ZH
	Symmetrical diffused light	● EN
	Luce simmetrica diffusa	● IT
	Lumière symétrique diffuse	● FR
	Symmetrisches diffuses Licht	● DE
	Luz simétrica difusa	● ES
	Симметричный рассеянный свет	● RU
	对称漫射光	● ZH
	Indirect light	● EN
	Luce indiretta	● IT
	Lumière indirecte	● FR
	Indirektes Licht	● DE
	Luz indirecta	● ES
	Непрямой свет	● RU
	间接光	● ZH
	Adjustable	● EN
	Orientabile	● IT
	Lumière orientable	● FR
	Schwenkbar	● DE
	Luz orientable	● ES
	Поворотный светильник	● RU
	可定向照明	● ZH

Art. 1 Recital
Unless otherwise provided for in a separate written agreement between the parties, every sale of products of Lodes S.r.l., VAT 02992370276 (hereinafter, "the Seller") is governed by the following General Conditions of Sale that must be considered as an essential part of this agreement and shall be deemed to have been accepted by the Buyer even though the latter has not signed them. Any clause unilaterally added by the Buyer in the documentation signed by it and /or in its correspondence, being against or in any case in addition to the general conditions or to those specific expressly approved in writing by the Seller, shall be deemed as not written and shall be of no effect.

Art. 2 Completion of the sale, quantities and prices
The sale is deemed to be completed once the Seller gives the written order confirmation also by fax and / or email or when deliveries are commenced in cases where the immediate delivery of the supply is requested, also in consideration of changes occurred and then accepted by the customer. The prices agreed are understood for products delivered ex works of the Seller and do not include services and accessory charges (such as VAT, special packaging, transport and installation costs, and /or assemblages and so on).

Art. 3 Delivery, risk transfer and transport
Products are delivered to the Buyer at the Seller's plant or at another place indicated in writing by the Seller, and the risk transfer takes place with the delivery of the goods to the first carrier or Buyer in the events of collection of goods directly carried out by the latter. The products always travel at the Buyer's sole risk also when the carrier is selected and appointed by the Seller, being the latter freed from all responsibilities after having delivered the products to the carrier, this delivery is deemed to all effects being carried out directly by the said Buyer. The delivery terms agreed are to be understood as indicative. If the Seller is responsible for delay of delivery for a period of up to 60 days, the Buyer is not entitled either to refuse the supply or to request the termination of the agreement and /or the compensation for any damages. If the delay in delivery exceeds 60 days, the Buyer is entitled to request – by registered letter – the cancellation of the order and the reimbursement of the advances if paid. In any event, the Seller shall not be liable for and /or direct and indirect damages of any nature and for any reason due to the delay or the failure to carry out the supply.

Art. 4 Reservation of title
The Buyer acquires property rights over the goods with the full payment of the price invoiced of the supplies but it takes the risks thereof as of the delivery.

Art. 5 Products features and conditions of use
Unless otherwise expressly agreed in writing by the parties, the conditions for using of the products are those communicated or in any case resulting from the drawings and technical specifications of the Seller, if any, or as described in the website www.lodes.com in relation to products. The quality levels of products are the standard quality levels of the Sellers, indicated in the relevant specifications as described on the Seller's website. It is always the Buyer's responsibility to identify and notify the Seller of the conditions of use of products before technically defining them. Failing any particular instructions from the Buyer, the Seller considers as usual conditions of use those it considered or described in its designs and technical documentation. Drawings, materials, and colours of the products included in catalogues/website and more generally in all advertising material are indicative. The Seller reserves the right, without notice, to modify the characteristics of its products, as well as their availability. Technical data, images, and information regarding the products are not binding on the Seller, who will not be held responsible for any discrepancies and / or illustrative and / or textual errors. Further product characteristics are contained in the respective technical sheets and /or instruction sheets.

Art. 6 Warranties
The products delivered are covered by a warranty for defects in material and manufacture for a period of 24 months as of the delivery if the Buyer is a natural person, otherwise the warranty period will be of 12 months as of the delivery. The Seller shall replace the products delivered in this warranty period being faulty due to factory defects or in alternative, at its discretion, pay the Buyer an amount equal to the price already invoiced of the said products, being expressly excluded and waived any other right or claim by the Buyer also as compensation for direct and /or indirect damages or cost repayment borne by it (such as recovery, technical assistance, recalling costs, etc.). The Seller will anticipate the delivery of the replaced product, invoicing it regularly. Successively, when the product arrives to the Seller's warehouse, the latter will credit the amount of the defective product. The transport's costs will be paid by the Seller. Should the defected item be returned in an inadequate non-original packaging, with damages connected to the transport, The Seller will not credit any amount to the Buyer, and it will return the product to the sender at his own expenses. If the replacement was made for alleged defects in material and manufacture, but after the control carried out by the Seller, it is considered (i) unfounded, due to the absence of defects; (ii) further damaged by insufficient packaging in the return transport (iii) spoiled by tampering made by the Buyer, all transportation costs and the entire value of the product will be charged to the latter. Any defectiveness or non-compliance of products shall be reported by the Buyer by writing to the Seller – in order to be valid – within 8 days from receipt of goods; any hidden defects shall be reported by the Buyer by writing to the Seller – always in order to be valid – within 8 days as of the relevant discovery. It being understood that the Seller will not be responsible for any defect even though hidden, being notified in writing, after 24 months of the delivery of goods. The warranty does not apply where the defects identified are due to the Buyer's negligence and /or to the use of products being not compliant with the information and explanations in any case gave by the Seller, technical provisions, to incorrect design, application, assembly or manufacture of the facilities in which they are installed, to incorrect maintenance carried out by unauthorized personnel, to improper cleaning since it is made with materials and manners being not suitable, to incorrect storage, handling and transport, to improper or imprudent use, also in the event of electrical system and its capacity being not suitable, or to circumstances that in any case cannot be related to the production defectiveness by the Seller. Every single product of the Seller corresponds to the mark laid down by the European Community with Directive 93 / 68 (extension of Directive 73 / 23) to confirm, with a mark recognized all over Europe, that the lights have undergone the electrical safety test required by European standards EN-60598-1-2 II ed. + CEI EN 60598-1 IV ed. corresponding to Italian standards CEI 34-21 + CEI 34-23, electrical safety standards referred to by all institutions, including the IMQ. The products indicated with the logo UL and /or ETL corresponds to the standards UL 1598 /CAN /USA C22.2 No.250.0 o UL 153.

Art. 7 Buyer's Obligations
The Buyer is required to immediately take delivery of the goods given by the Seller to the carrier, or – where otherwise agreed – to timely collect them at the Seller's plant on the date on which the Seller communicates, by any means, that the goods are ready. Where the Buyer delays the collection of the production for a period exceeding 10 days, in addition to the payment of price it shall pay the Seller a proper compensation equal to 2% per day of the price invoiced for storing such products. The Buyer shall carry out the payments normally, in accordance with the terms and conditions specified in the invoice. For late payments it will be accrued by default without need of further notification interest under Legislative Decree no. 231 / 2002. In the event of payment delays, the Seller is entitled to immediately suspend any supply, even though it has concluded other agreements with the same Buyer. The failure to pay within the terms agreed will cause in any event the loss of favourable terms for the Buyer.

Art. 8 Replacement of the Product
If a product is returned for commercial reasons or for a mistake in the order made by the Buyer, the Seller will retain an amount equal to the 20% of the total price as cost for reconditioning the product. If the returned product had already been used and / or it has been returned in an inadequate original packaging, with consequent transport damages, the Seller will not credit to the Buyer any amount and it will return the product to the sender at his own expenses. Only the articles in the catalogue and in the price list in force at the time of the request will be taken into consideration. Transport's costs are always charged to the Buyer. The repair of damaged products will be authorized only if the damage has been caused by the Buyer. The Buyer, once accepted repair costs, will take care of returning the damaged product to the Seller's warehouse and it will pay the costs of transporting the repaired product.

Art. 9 Force majeure
If the Seller is unable to comply with the agreement due to force majeure or beyond its control events, the deadlines set for the supply are automatically extended for a period in which these effects continue. Where the obstacle to comply with the agreement is longer than 6 months, both parties may request the termination of the agreement and, in such event, the Seller repay the Buyer the advances received, if any, releasing itself from any additional obligation on it.

Art. 10 Agreement
In the event of execution of a specific agreement signed by the parties, the said agreement together with its Annexes provides for and summarizes the obligations validly undertaken by the parties and being binding for them. The fulfilment by the parties will be subject to effective evaluation of the actual performance of the contractual tasks and duties to be carried out in good faith, with honesty and fairness. These General Conditions of Sale shall apply to the agreement, unless otherwise provided in writing by the parties or expressly provided in the said agreement.

Art. 11 Privacy Policy
The Seller will use the data received from the Buyer in accordance with the provisions of the article 13 of EU Regulation 2016 /679 of 27 April 2016 (GDPR). For more information are available at the following link: www.lodes.com/privacy-policy.

Art. 12 Disputes
Any dispute which may arise concerning the signing, validity, interpretation, performance, amendment and termination of the agreement or of these General Conditions of Sale will be settled according to principles and rule set forth in Article 13 below.

Art. 13 Jurisdiction and Applicable Law
The Court of Milan, Italy, shall be held exclusively competent, being any other court of competent jurisdiction expressly excluded, and the Italian Law shall be applicable.

Art. 14 Website
These General Conditions of Sale are those indicated on the website www.lodes.com and may be printed and reproduced on paper. The Seller undertakes to update the website www.lodes.com by publishing on it the version of the General Conditions of Sale as amended from time to time.

Art. 1 Premessa
Salvo deroga risultante da apposito accordo scritto tra le parti, ogni compravendita di prodotti di Lodes S.r.l., P.IVA 02992370276 (di seguito: "Venditore") è regolata dalle seguenti Condizioni Generali di Vendita che costituiscono parte essenziale del contratto e che si intendono pertanto accettate dal Compratore ancorché dallo stesso non sottoscritte. Qualsiasi clausola unilateralmente apposta dal Compratore nei documenti da lui sottoscritti e/o nella sua corrispondenza, che sia contraria o comunque in aggiunta alle seguenti condizioni generali od a quelle speciali espressamente approvate per iscritto dal Venditore, si intende come non scritta ed è priva di ogni effetto.

Art. 2 Perfezionamento della compravendita, quantitativi e prezzi
La compravendita si intende perfezionata con la conferma d'ordine scritta del Venditore anche a mezzo fax e/o posta elettronica o con l'inizio delle consegne per i casi in cui è stata richiesta l'immediata consegna della fornitura anche in presenza di modifiche intervenute e quindi accettate dal cliente. I prezzi concordati si intendono per prodotti consegnati franco stabilimento del Venditore e non comprendono prestazioni ed oneri accessori (quali IVA, imballo speciale, spese di trasporto, di installazione e/o montaggi e così via).

Art. 3 Consegna, trasferimento del rischio e trasporto
La merce viene consegnata al Compratore presso lo stabilimento del Venditore o in altro sito dallo stesso indicato per iscritto, ed il trasferimento del rischio avviene con la consegna della stessa al primo vettore o al Compratore nelle ipotesi di ritiro della merce da quest'ultimo direttamente eseguita. La merce viaggia sempre a rischio esclusivo del Compratore anche quando il vettore dovesse essere scelto ed incaricato dal Venditore, essendo quest'ultimo liberato da ogni responsabilità con la consegna dei prodotti al vettore, che ad ogni effetto si intende eseguita a mani dallo stesso Compratore. I termini di consegna pattuiti si intendono indicativi. In caso di ritardo nella consegna imputabile al Venditore per un periodo fino a 60 gg il Compratore non ha il diritto di rifiutare la fornitura, né di richiedere la risoluzione del contratto e/o il risarcimento di alcun danno. Se il ritardo nella consegna supera il termine di 60 gg il Compratore ha la facoltà di richiedere – con lettera raccomandata – l'annullamento dell'ordine e la restituzione degli anticipi eventualmente versati. Resta in ogni caso escluso qualsivoglia obbligo del Venditore di risarcimento danni diretti e/o indiretti di qualsiasi natura e per qualsiasi ragione, in dipendenza del ritardo ovvero della mancata esecuzione della fornitura.

Art. 4 Riserva di proprietà
Il Compratore acquista la proprietà della merce solo con il pagamento integrale del prezzo fatturato delle forniture ma ne assume i rischi dal momento della consegna.

Art. 5 Caratteristiche dei prodotti e condizioni di utilizzo
Salvo diverso ed espresso accordo scritto tra le parti, i parametri funzionali dei prodotti sono quelli espressi comunicati o comunque risultanti nei disegni e specifiche tecniche del Venditore se esistenti o su quanto indicato sul sito web www.lodes.com relativamente ai prodotti. I livelli di qualità dei prodotti forniti sono quelli standard del Venditore, evidenziati nelle relative specifiche o su quanto indicato e desumibile sul sito web del Venditore. È onere del Compratore individuare e comunicare al Venditore le condizioni di utilizzo dei prodotti prima della relativa definizione tecnica. In mancanza di indicazioni da parte del Compratore il Venditore considera condizioni di utilizzo quelle di prassi dallo stesso considerate o esplicitate nei propri disegni e documentazione tecnica. I disegni, i materiali ed i colori dei prodotti inseriti sui cataloghi/sito internet e più in generale in tutto il materiale pubblicitario, si intendono a titolo indicativo. Il Venditore, si riserva il diritto, senza alcun preavviso, di modificare le caratteristiche dei propri prodotti,

così come la disponibilità degli stessi. I dati tecnici, le immagini e le informazioni riguardo ai prodotti non sono vincolanti per il Venditore, il quale non risponderà per eventuali difformità e/o errori illustrativi e/o testuali. Ulteriori caratteristiche dei prodotti sono contenute nelle relative schede tecniche e/o fogli di istruzione.

Art. 6 Garanzie
I prodotti forniti sono coperti da garanzia per difetti di materiale e/o fabbricazione per un periodo di 24 mesi dalla consegna se il Compratore risulta essere una persona fisica, diversamente il periodo di garanzia sarà di 12 mesi dalla consegna. Il Venditore sostituisce i prodotti resi in detto periodo di garanzia e riconosciuti difettosi per vizi d'origine ovvero in alternativa ed a sua scelta accredita al Compratore una somma pari al prezzo già fatturato dei prodotti stessi, restando espressamente escluso e rinunciato qualsiasi diverso diritto o pretesa del Compratore anche a titolo di risarcimento danni diretti e/o indiretti o di rimborso di costi dallo stesso sostenuti (quali costo di riprese, di assistenza tecnica, di richiamo, ecc.). Il Venditore anticiperà l'invio del prodotto in sostituzione, fatturandolo regolarmente, andando poi ad accreditare l'importo alla riconsegna del prodotto difettoso reso. Le spese di trasporto saranno a carico del Venditore. Qualora l'articolo oggetto del reso venisse riconsegnato in un imballo non originale inadeguato con conseguenti danni da trasporto, il Venditore non accrediterà al Compratore alcun importo e rinverrà al mittente, a sue spese il prodotto. Qualora il reso venisse effettuato per presunti vizi d'origine ma dopo il controllo effettuato dal Venditore lo stesso venisse ritenuto (i) infondato, per assenza di vizi; (ii) ulteriormente danneggiato da insufficiente imballaggio nel trasporto di ritorno (iii) viziato da manomissione posta in essere dal Compratore, verranno addebitati a quest'ultimo tutti i costi di trasporto nonché l'intero valore del prodotto. Eventuali difettosità o non conformità dei prodotti devono essere segnalate dal Compratore per iscritto al Venditore – a pena di decadenza – entro e non oltre 8 gg dalla data di ricevimento della merce; eventuali difetti occulti devono essere segnalati dal Compratore per iscritto al Venditore – sempre a pena di decadenza – entro 8 gg dalla relativa scoperta. Resta inteso che il Venditore non sarà responsabile per alcun vizio ancorché occulto, comunicato per iscritto, oltre 24 mesi dalla consegna della merce. La garanzia non opera ove i difetti rilevati siano imputabili a negligenza del Compratore e/o ad impiego dei prodotti non conforme con le informazioni e le spiegazioni in ogni caso fornite dal Venditore, alle prescrizioni tecniche, ad errata progettazione, applicazione, montaggio o fabbricazione delle strutture ove sono installati, ad errata manutenzione operata da personale non autorizzato, a pulizia impropria in quanto effettuata con modalità o materiali non idonei, ad errato magazzino, movimentazione e trasporto, ad uso improprio od incauto, anche in caso di impianto elettrico e portata dello stesso non idonea, ovvero a circostanze che comunque non possono ricollegarsi a difettosità di produzione da parte del Venditore. Ogni singolo prodotto del Venditore è conforme alla marcatura richiesta dalla Comunità Europea con la direttiva 93/68 (ampliamento della direttiva 73 /23) per confermare con una marcatura riconosciuta in tutta Europa, che le lampade sono state sottoposte alle prove di sicurezza elettrica richieste dalle norme Europee EN-60598-1-2 II ed. + CEI EN 60598-1 IV ed. corrispondenti norme italiane CEI 34-21 + CEI 34-23, norme per la sicurezza elettrica a cui fanno riferimento tutti gli istituti, compreso l'IMQ. I prodotti indicati con il marchio UL e/o ETL sono conformi alla normativa UL 1598 /CAN /USA C22.2 No.250.0 o UL 153.

Art. 7 Obblighi del Compratore
Il Compratore è tenuto a prendere immediatamente in consegna i prodotti affidati dal Venditore al vettore, ovvero – se diversamente concordato – apuntualmente ritirarli presso lo stabilimento del Venditore alla data di comunicazione di merce pronta che potrà avvenire con ogni mezzo da parte del Venditore. Ove il Compratore ritardi il ritiro dei prodotti per un periodo superiore a 10 gg, oltre al pagamento del prezzo deve corrispondere al Venditore un adeguato compenso pari al 2% al giorno dell'importo fatturato per il magazzino

degli stessi. Il Compratore deve effettuare i pagamenti normalmente, con le modalità e nei termini precisati in fattura. Sui ritardati pagamenti decorreranno, di pieno diritto e senza necessità di costituzione in mora, gli interessi di cui al D.lgs. n. 231 /2002. In caso di ritardo dei pagamenti il Venditore ha diritto a sospendere immediatamente ogni fornitura, anche se dipendente da altri contratti con lo stesso Compratore. Il mancato pagamento nei termini pattuiti comporta in ogni caso la decadenza del Compratore dal beneficio del termine.

Art. 8 Resi
In caso di reso commerciale o in caso di reso per errore del Compratore, il Venditore tratterà un importo pari al 20% minimo del totale a titolo di costo di ricondizionamento dell'articolo. Qualora l'articolo oggetto del reso fosse già stato utilizzato e/o venisse riconsegnato in un imballo non originale inadeguato, con conseguenti danni da trasporto, il Venditore non accrediterà al Compratore nessun importo e rinverrà al mittente, a sue spese, il reso. Verranno presi in considerazione solamente gli articoli presenti nel catalogo e nel listino in vigore al momento della richiesta. Le spese di trasporto sono sempre a carico del Compratore. I resi per riparazione vanno autorizzati solo se la causa del danno è dipesa dal Compratore che dopo aver accettato il costo di riparazione si occuperà a proprie spese di rispedire l'articolo danneggiato in sede e si accollerà poi i costi relativi al trasporto del prodotto riparato.

Art. 9 Forza maggiore
Qualora il Venditore sia impossibilitato a rispettare il contratto per cause di forza maggiore o comunque indipendenti dalla sua volontà, i termini previsti per l'esecuzione della fornitura sono automaticamente prorogati per un periodo equivalente al perdurare degli effetti di tali cause. Qualora la causa impeditiva continui per più di 6 mesi entrambe le parti possono chiedere la risoluzione del contratto ed in tal caso il Venditore restituisce al Compratore gli anticipi eventualmente ricevuti, con esclusione di ogni e qualsiasi onere ulteriore a suo carico.

Art. 10 Contratto
In caso di sottoscrizione di apposito contratto lo stesso con i suoi allegati contiene e riassume le obbligazioni validamente assunte dalle parti e per esse vincolanti. L'adempimento delle parti sarà oggetto di valutazione dell'effettiva esecuzione dei compiti e doveri contrattuali, da effettuarsi in buona fede, onestà e con equità. Le presenti Condizioni Generali di Vendita si applicheranno al contratto salvo deroga risultante da atto scritto o in esso contratto esplicitamente prevista.

Art. 11 Trattamento dei Dati Personali
Il Venditore utilizzerà i dati ricevuti dal Compratore conformemente alle disposizioni vigenti in materia di Privacy secondo l'art.13 del Regolamento Europeo 2016 /679 (GDPR). Maggiori informazioni sono disponibili al seguente link www.lodes.com/it/privacy-policy.

Art. 12 Controversie
Qualora dovesse verificarsi una qualsivoglia controversia avente ad oggetto la formazione, validità, interpretazione, esecuzione, modifica e risoluzione del contratto o delle presenti Condizioni Generali di Vendita, questa sarà risolta secondo i principi e le regole indicate nell'articolo 13 che segue.

Art. 13 Foro competente e legge applicabile
Foro esclusivamente competente sarà quello di Milano con esplicita esclusione di ogni altro foro alternativamente competente, e la legge applicabile quella italiana.

Art. 14 Sito Web
Le presenti Condizioni Generali di Vendita, sono quelle risultanti sul sito web www.lodes.com e sono stampabili e riproducibili su supporto cartaceo. Il Venditore si impegna ad aggiornare il sito web www.lodes.com mediante la pubblicazione sullo stesso della versione di Condizioni Generali di Vendita di volta in volta modificata.

Terms and Conditions of Sale 2023/2024
Lodes Usa LLC

PRICES

The Prices shown in the LODES price list, or any order acknowledgement, are prices prevailing at the present time. Prices issued by a written quotation are firm for 60 (sixty) days from date of quotation. Prices are F.O.B. Edison, NJ. List prices do not include shipping charges, storage, sales and other taxes, or installation. LODES reserves the right to change prices prior to order without advanced notice.

ORDERING PROCEDURES

All orders must be in writing to avoid error and / or duplication. Telephone or verbal orders are not accepted. All purchase orders can be e-mailed directly to: usa@lodes.com

Change or cancellation of an order is not accepted without written consent from LODES.

Special orders cannot be changed or cancelled under any circumstances. Change or cancellation of standard stock orders must be made prior to shipment of goods. Notification of changes or cancellations must be in writing and directed to LODES. To expedite your order please make sure to provide the proper product name, quantity and color.

ADDITIONS

Additions to orders already received and entered in to production will be considered new orders.

ORDER/SIZE

LODES stock levels are maintained to provide for your immediate needs. Please call us at 201-903-0020 or email us at usa@lodes.com for large quantity orders.

PAYMENT TERMS

Unless otherwise agreed in writing, payment in full is due prior to the shipment of any goods. LODES Credit Manager will make credit sales only after receipt of a signed LODES, credit application and written credit approval. On all credit sales payment in full is due on the following terms: Net 30 days unless otherwise agreed to in writing by both parties. All payments not made by the due date shall bear interest at a rate of one and one-half (1.5) percent per month on the unpaid balance. Further, the Buyer shall reimburse and indemnify LODES for any and all costs of collection incurred in collecting any past due sums, including but not limited to collection agency fees, court fees, out-of-pocket expenses and reasonable attorney fees. At its option LODES, may decline to make shipment to Buyer if any invoice is past due. Buyer waives and releases any claim against LODES, for loss or damage actually and / or allegedly sustained by Buyer as a result of LODES, refusal to make shipment under such circumstances. All payments shall be made in U.S. dollars and, unless otherwise designated by LODES in writing, shall be sent to LODES, at the address listed below. For all custom orders a 50% non-refundable deposit is required prior to delivery.

LODES USA LLC
560 Springfield Avenue, Suite B
Westfield NJ 07090

Purchaser may make payment via major credit cards, PayPal or wire transfer. Orders over \$500.00, not including freight, are subject to a 3% credit card fee. For orders over \$10,000, customers with previously established credit may pay a 50% deposit upon placement of order with the balance due prior to shipment.

STORAGE

In the event that the Purchaser requests post payment of delivery beyond the scheduled shipping date and the goods are in production, LODES, may transfer the goods, when ready for shipment, to storage at the Purchaser's risk and expense.

SHIPMENTS

All orders are shipped F.O.B. Edison, NJ. LODES will select the method of shipment unless otherwise requested by the Purchaser with special instructions.

DROP SHIPMENTS

Drop shipments to customers are available at no additional cost. All standard terms and conditions apply.

FREIGHT CHARGES

Unless otherwise specifically requested by the Purchaser, all truck deliveries are pre-paid by LODES and billed to the Purchaser with the goods. 20% of the freight charge is added for the prepayment and handling. For shipment of merchandise via UPS LODES will charge a minimum freight and handling fee of \$10.00.

PACKAGING AND SHIPPING

Method of packaging is at LODES, option. All merchandise will be shipped by UPS, or common carrier, unless otherwise specified.

RETURNS

Requests to return non-defective merchandise must be made within 30 days from date of shipment and is subject to a minimum 30% restocking charge. All returned goods must be accompanied by a Returned Material Authorization (R.M.A.) issued by LODES. Only standard products from the current catalog are returnable. Custom orders or discontinued products are not subject to return. Merchandise must be returned in the original factory sealed cartons in sellable condition. Returns must be made freight prepaid within 30 days of the date of LODES's issuance of the R.M.A. All merchandise returned is subject to inspection. Credit will not be issued for damaged merchandise.

CLAIMS AND ADJUSTMENTS

All products from LODES are shipped free of defects. All products are shipped at Purchaser's risk. Responsibility for any product damage incurred during shipment is transferred to the transportation company upon pick up and the title passes to Buyer upon delivery by LODES carrier. Claims for shortages, losses and apparent or concealed damages sustained in transit shall be made by Buyer with the carrier. Buyer must notify the freight company, as well as LODES within 7 days. For shipments made by common carrier, claims for damage must be made directly to the carrier.

WARRANTY

LODES warrants its products to be free of defects in materials and workmanship for a period of one year from date of delivery of the products. During this warranty period LODES will repair or at its option replace free of charge, products that are proven to be defective. This warranty does not apply to damages resulting from accident, alteration, tampering, misuse, negligence or abuse. ANY IMPLIED WARRANTY OF MERCHANTABILITY OR FITNESS FOR A PARTICULAR PURPOSE AND ALL IMPLIED WARRANTIES ARISING FROM A COURSE OF DEALING, USAGE OF TRADE, BY STATUTE OR OTHERWISE, IS HEREBY STRICTLY LIMITED TO THE TERM AND CONDITION OF THE MANUFACTURER DELIVERED WITH THE PRODUCT.

PRODUCT SPECIFICATIONS

At any time, any of the manufacturers distributed by LODES may introduce changes to improve the quality of their products while maintaining the basic features of the articles shown in their corresponding catalogs. The drawings, materials, and colors of the products included in catalogues/website and more generally in all advertising material are indicative. LODES reserves the right, without notice, to modify the characteristics of its products, as well as their availability. Technical data, images, and information regarding the products are not binding LODES, who will not be held responsible for any discrepancies and / or illustrative and/or textual errors. Further product

characteristics are contained in the respective technical sheets and / or instruction sheets. Every product has a one-year guarantee. If the products are faulty, they will be replaced or repaired free of charge. In case of wrong use or installation this warranty is not valid.

INDEMNITY

Buyer is solely responsible for the selection, installation, and use of the goods. Therefore, to the fullest extent permitted by law, Buyer agrees to defend and indemnify LODES from and against any claims or damage, including attorney's fees, expert's or consultant's fees arising from or relating to such selection, installation, and use. This indemnity applies regardless of any action and/or passive negligent act or omission on the part of LODES or its employees. However, Buyer shall not be obligated to indemnify LODES for the sole negligence or willful misconduct of LODES or its employees.

GOVERNING LAW

The internal laws of the state of New Jersey, other than the choice of law rules of the state of New Jersey, shall govern the validity, interpretation and enforcement of these terms and conditions.

All claims or disputes arising out of or otherwise relating to these terms and conditions shall be decided exclusively by Court of the Southern District of New York.

LODES USA, LLC
560 Springfield Avenue, Suite "B"
Westfield, NJ 07090
E-mail: usa@lodes.com
T 201-903-0021

Head offices & showroom

Lodes, via Pialoi 32,
30020 Marcon (Venezia) Italy
T +39 041 45 69 266
General information
info@lodes.com

Lodes USA LLC
560 Springfield Avenue, Suite B
Westfield, NJ 07090 – USA
D 201 903 0020
usa@lodes.com

Lodes' Hong Kong Office
Unit 507 Arion Commercial
Centre, 2–12 Queen's Road West
Sheung Wan, Hong Kong

Lodes Milan showroom

via della Moscova 33,
Cortile della Seta
20121 Milano (MI) Italy
T +39 02 4940 0999
milano@lodes.com

Lodes Flagships

Lodes Paris
Novaluce
131 rue du Faubourg
Saint Honoré,
75008 Paris 8e, France
T +33 (0) 1 42 89 03 18
paris@lodes.com

Lodes Cologne
Design Post Köln
Deutz-Mülheimer-Str. 22a
50679 Köln, Germany

Lodes 2024
Collection Catalogue

*Art direction
and graphic design*
Multi Form

Images
Bruger Studio
Operavisual
(p. 021, 028, 054, 061,
073, 078, 111, 205,
371, 405)

Photography
Mattia Balsamini
(p. 001–003, 006–010)
Maurizio Polese
(p. 052, 126, 144, 159,
212, 229, 267)
Studio Pointer
(p. 062, 066, 238, 297,
300, 322, 329, 331,
357, 358, 363, 364, 381,
383)

Copywritings
Lodes

Colour separation
Grafica Antiga
Luce Group

Printing
Grafiche Antiga

