

# LODES

5 lights round small-large  
9 lights round small-large  
7 lights oval / 11 lights oval  
*design by Lodes, 2026*

Cluster System

Light source	5 lights round small 5 lights round large	9 lights round small 9 lights round large
	↘ 220-240 V ~ 50/60 Hz ↘ Max load 5 x 57W	↘ 220-240 V ~ 50/60 Hz ↘ Max load 9 x 57W
	7 lights oval	11 lights oval
	↘ 220-240 V ~ 50/60 Hz ↘ Max load 7 x 57W	↘ 220-240 V ~ 50/60 Hz ↘ Max load 11 x 57W

↘ This canopy is to be used exclusively for the installation of Lodes luminaires

↘ Questo rosone va utilizzato esclusivamente per l'installazione di apparecchi Lodes

265IS04E1101\_Rev00

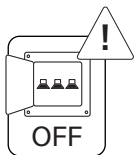

**EN** Before installing the device and, in any case, before any maintenance work, always disconnect the power supply.

**IT** Prima di installare l'apparecchio e comunque prima di ogni manutenzione togliere la tensione di alimentazione.

**FR** Avant d'installer le luminaire et avant toute opération de maintenance, couper l'alimentation électrique.

**DE** Vor der Installation des Geräts und in jedem Fall vor jeder Wartung ist die Stromversorgung zu unterbrechen.

**ES** Antes de instalar el aparato y en cualquier caso antes de cada mantenimiento cortar la alimentación.

**RU** Перед установкой прибора и перед проведением техобслуживания отключите электропитание.

**ZH** 安装照明设备以及进行任何维护之前均应断开电源。

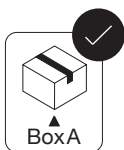

5 LIGHTS ROUND SMALL

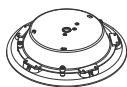

5 LIGHTS ROUND LARGE

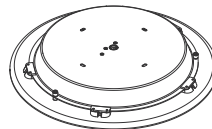

9 LIGHTS ROUND SMALL

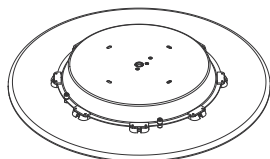

9 LIGHTS ROUND LARGE

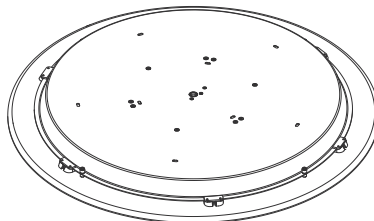

7 LIGHTS OVAL

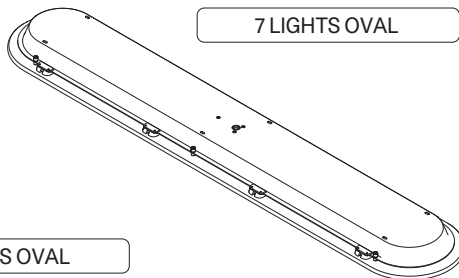

11 LIGHTS OVAL

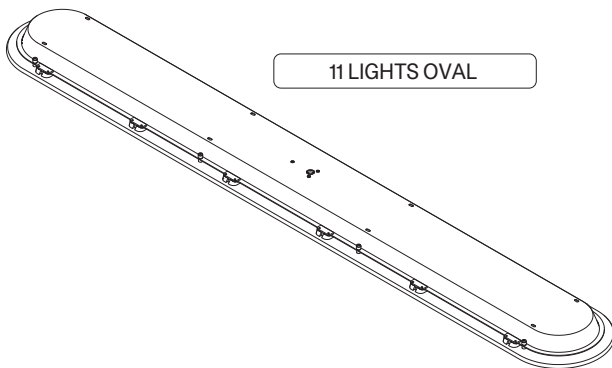

5 LIGHTS ROUND SMALL	x3
5 LIGHTS ROUND LARGE	x3
9 LIGHTS ROUND SMALL	x3
9 LIGHTS ROUND LARGE	x4
7 LIGHTS OVAL	x6
11 LIGHTS OVAL	x8

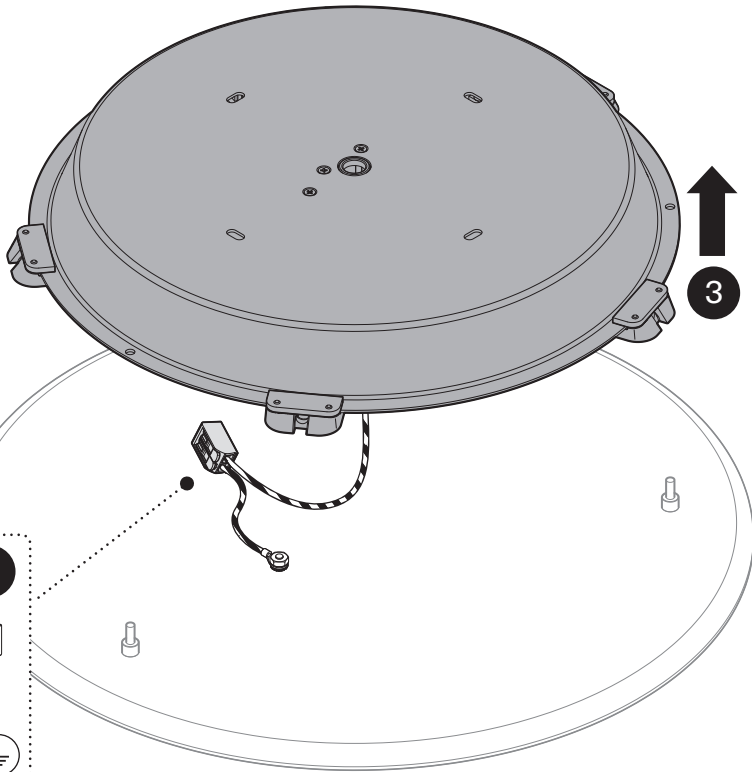
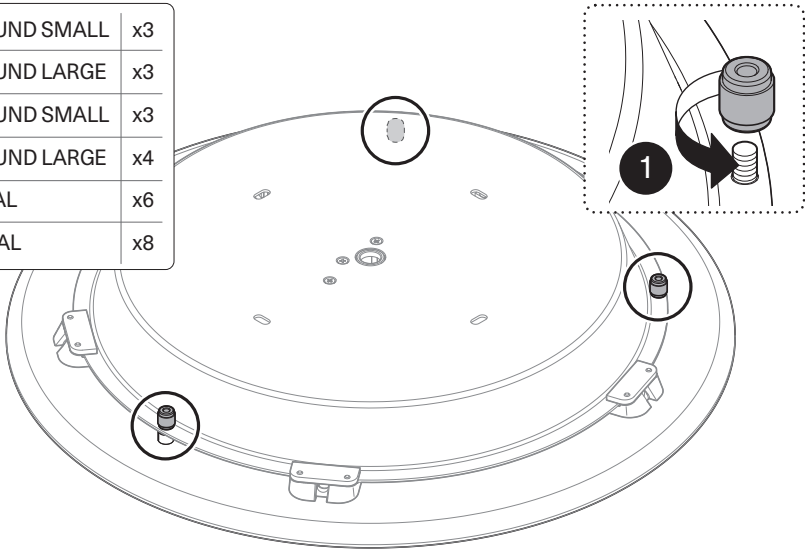

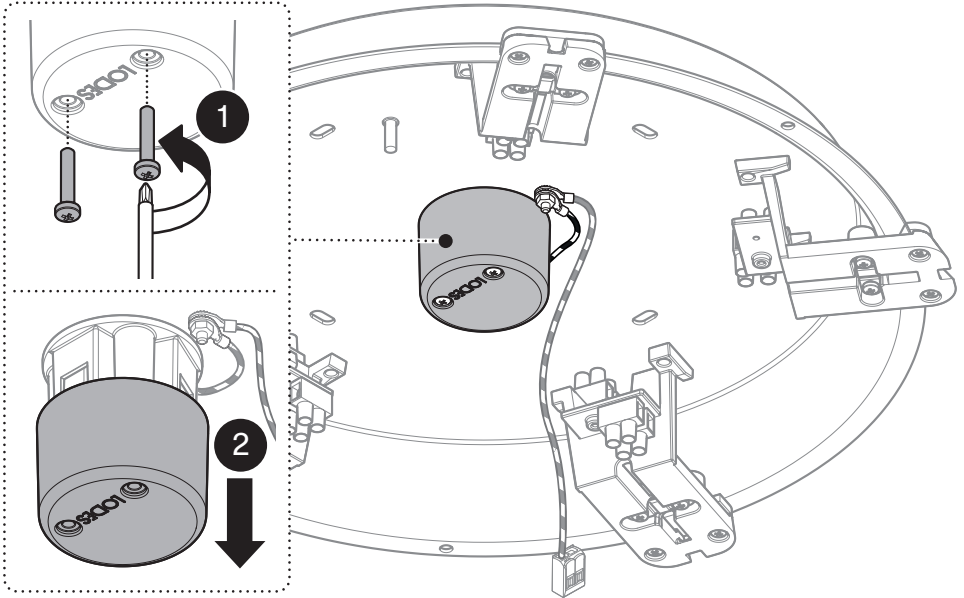

9 LIGHTS ROUND SMALL

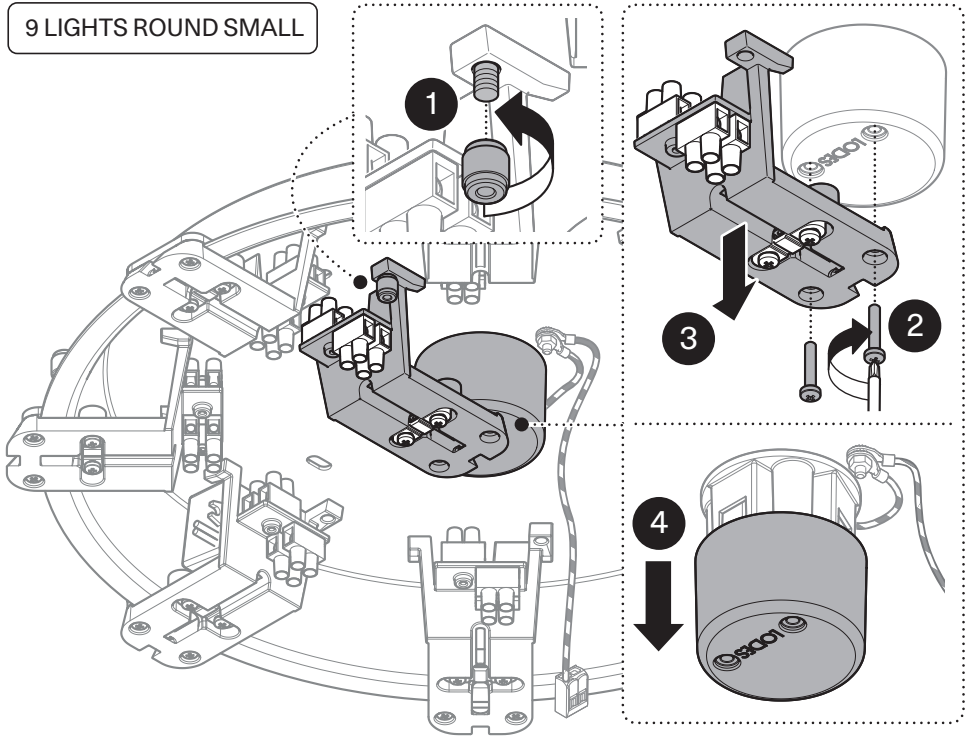

5 LIGHTS  
ROUND SMALL

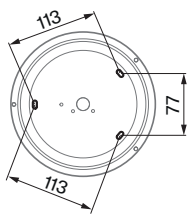

5 LIGHTS ROUND LARGE  
9 LIGHTS ROUND SMALL

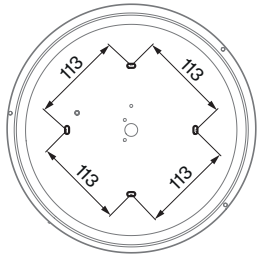

9 LIGHTS  
ROUND LARGE

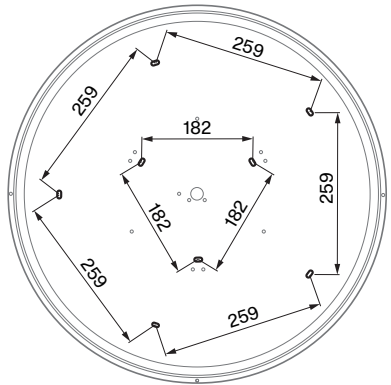

7 LIGHT  
OVAL

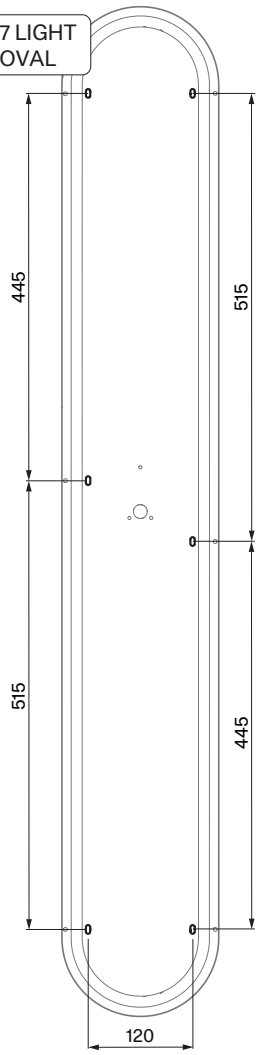

11 LIGHT  
OVAL

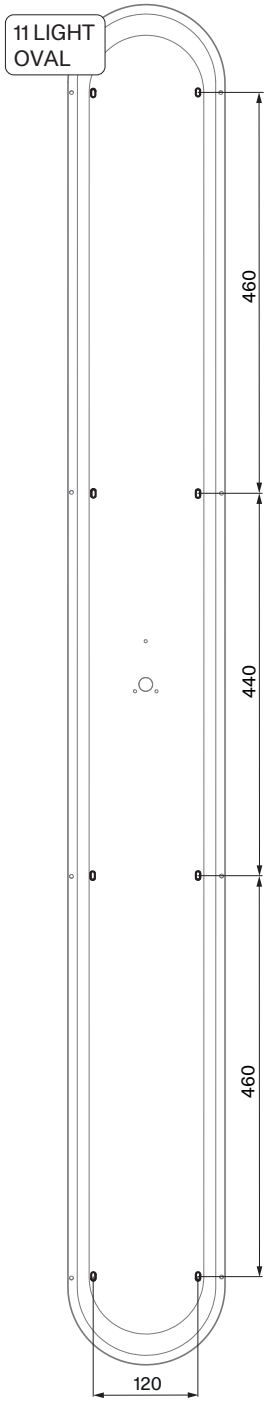

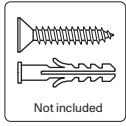
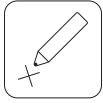

5 LIGHTS ROUND SMALL	x3
5 LIGHTS ROUND LARGE	x4
9 LIGHTS ROUND SMALL	x4
9 LIGHTS ROUND LARGE	x8
7 LIGHTS OVAL	x6
11 LIGHTS OVAL	x8

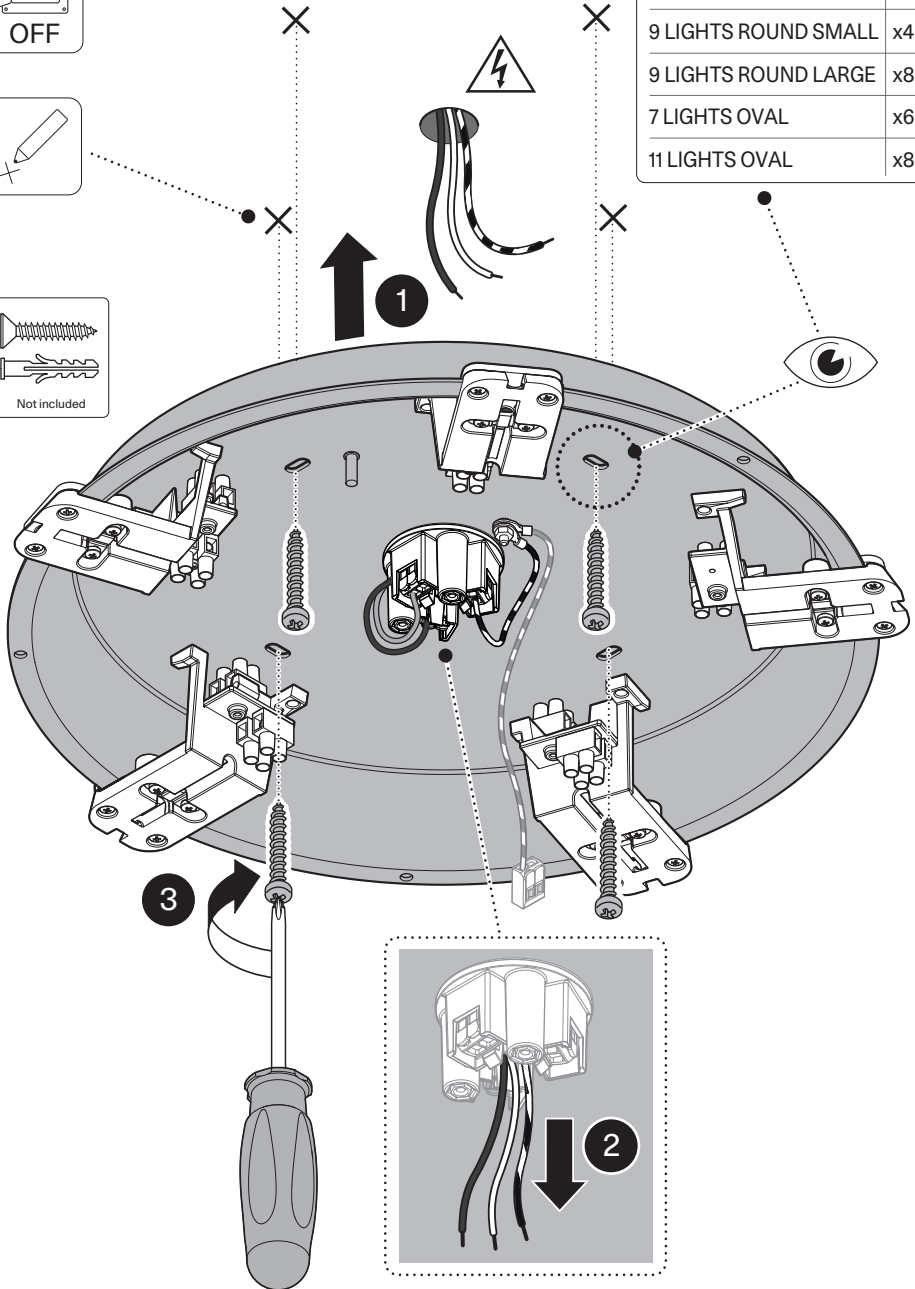

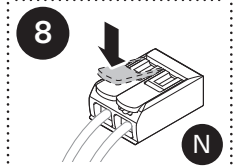
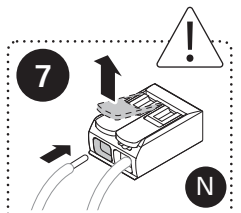
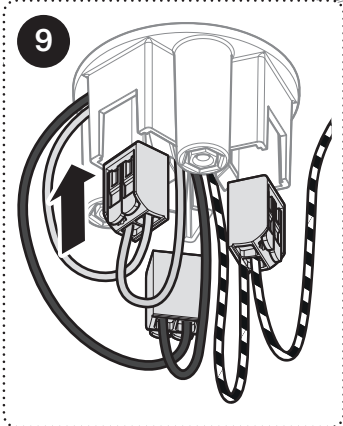
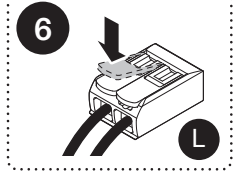
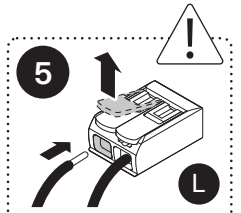
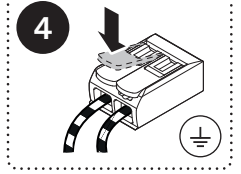
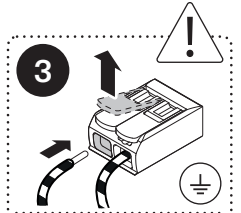
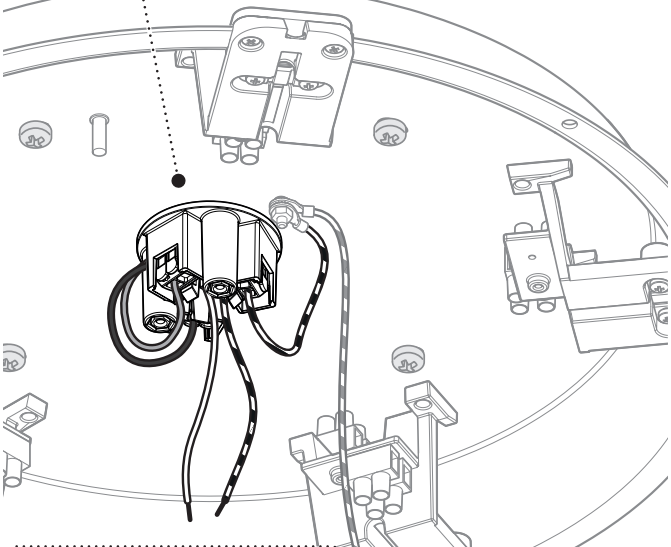
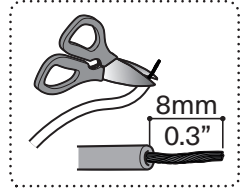
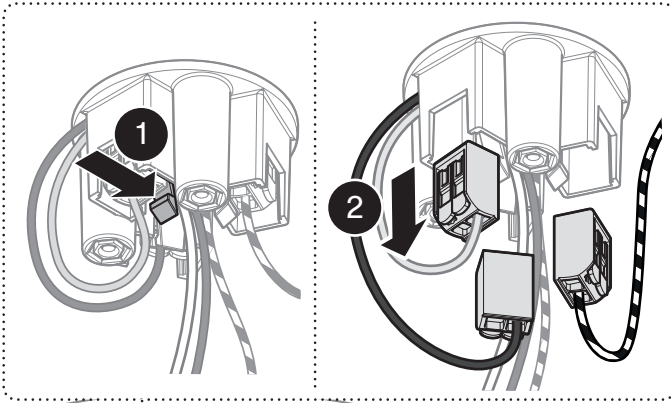

9 LIGHTS ROUND LARGE | x4

9 LIGHTS ROUND SMALL | x3

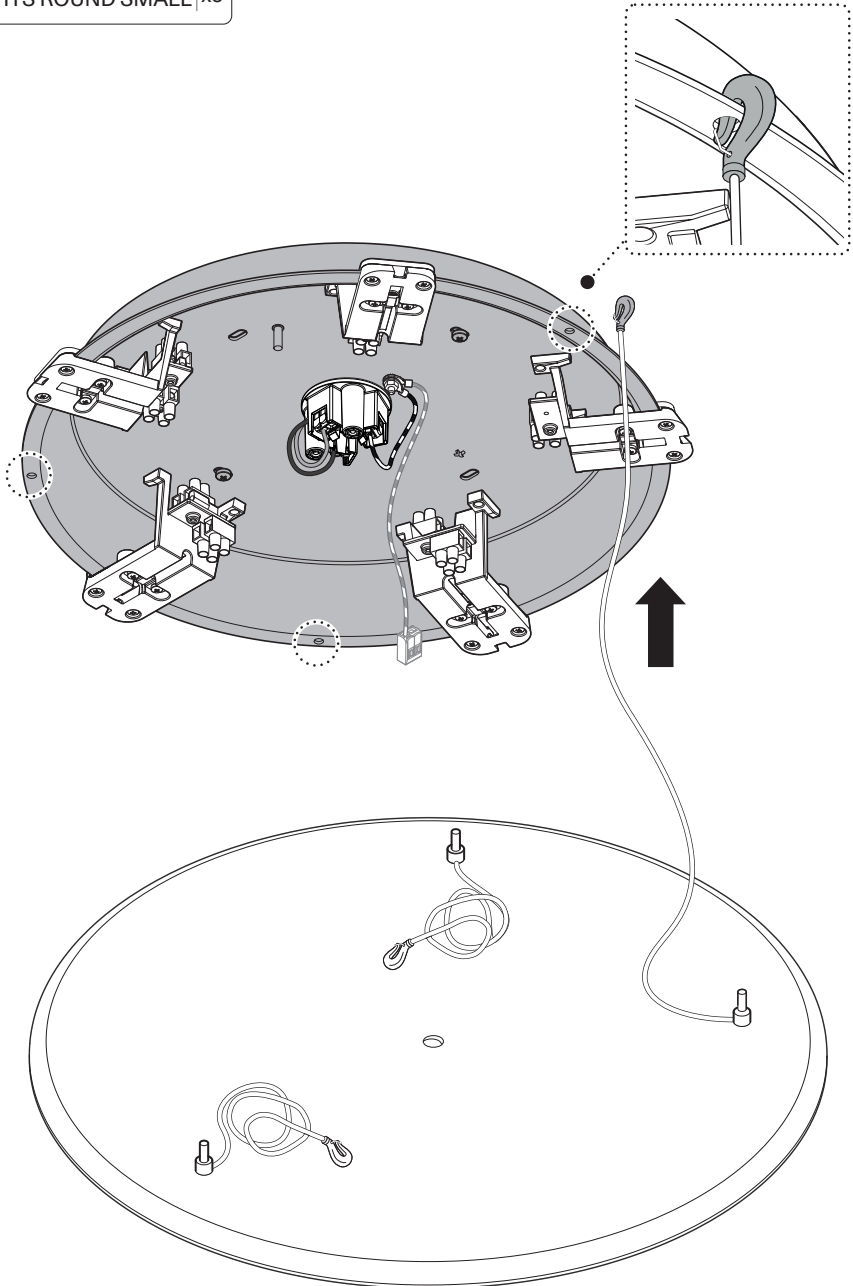

9 LIGHTS ROUND LARGE

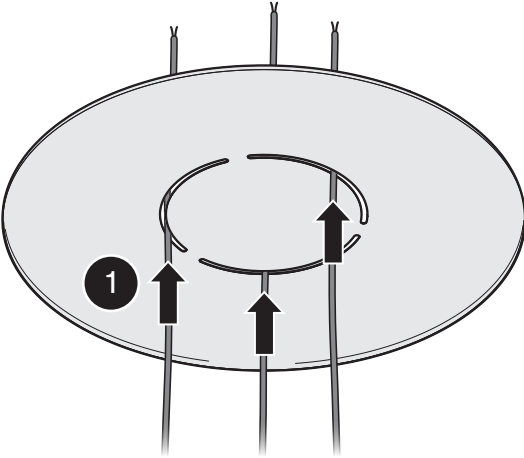

9 LIGHTS ROUND SMALL

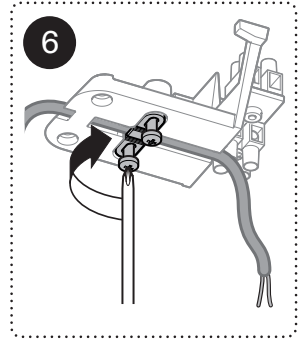
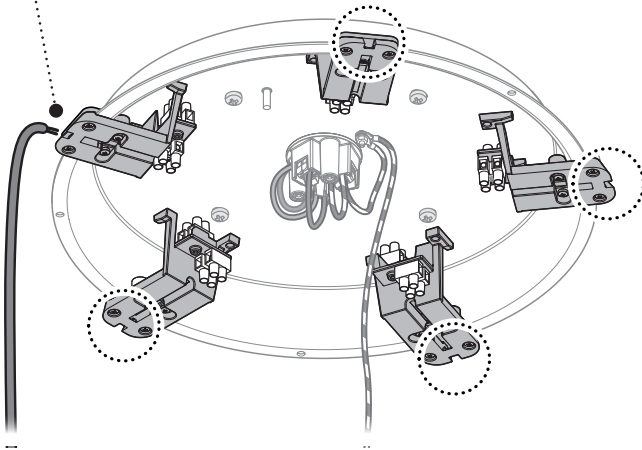
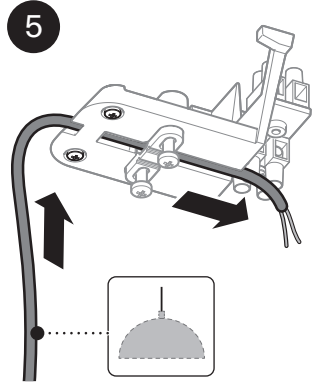
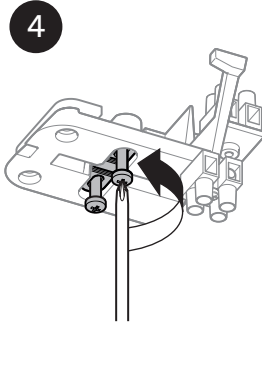
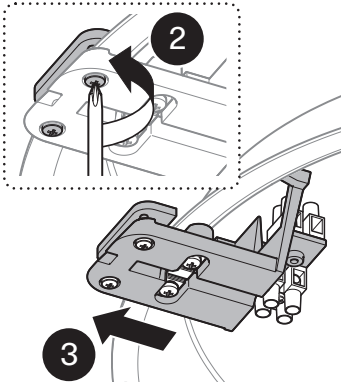
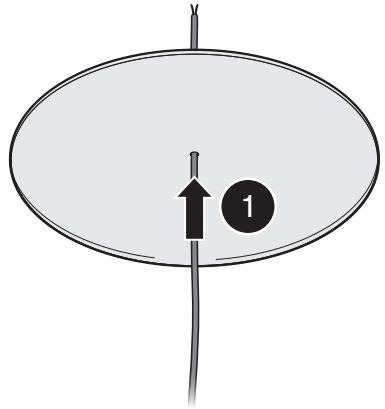

without driver LED

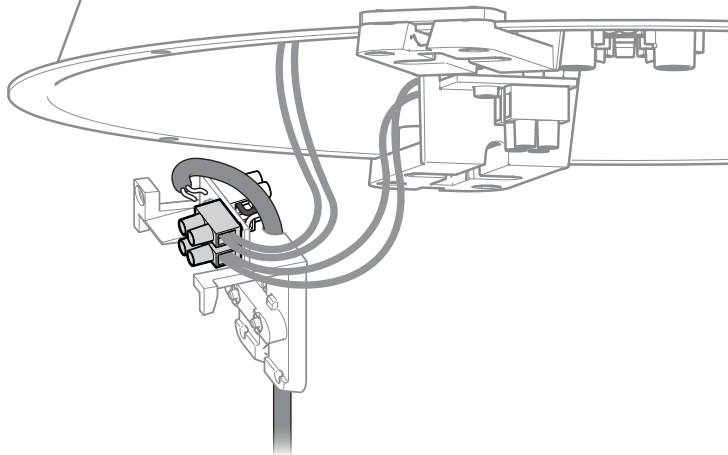

1

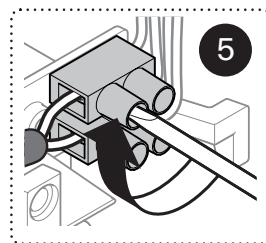
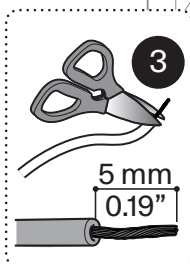
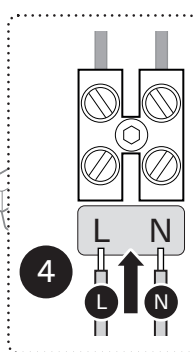
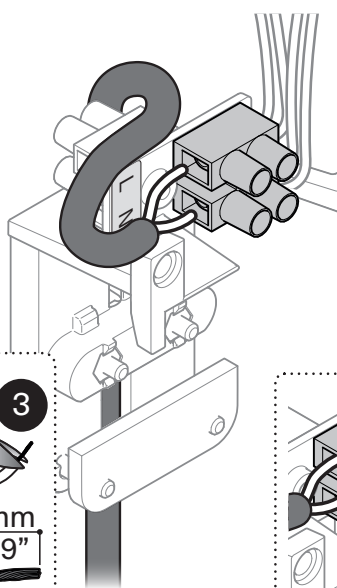
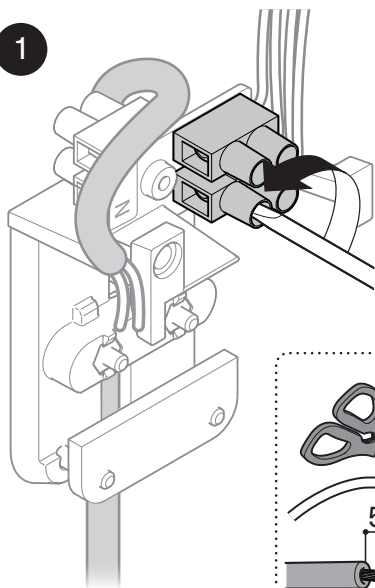

with driver LED

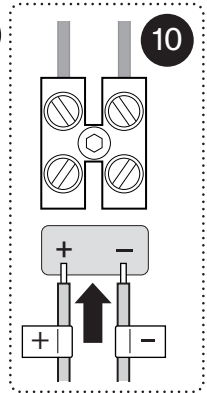
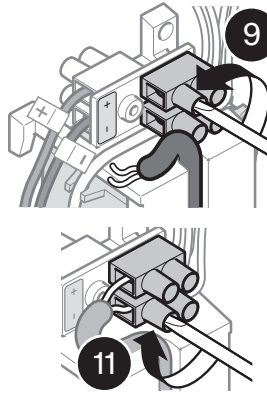
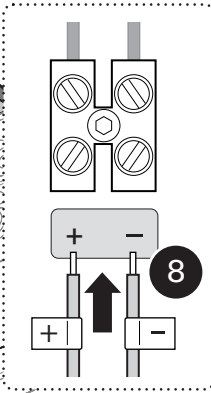
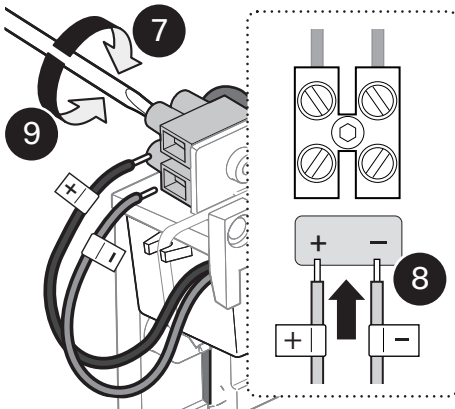
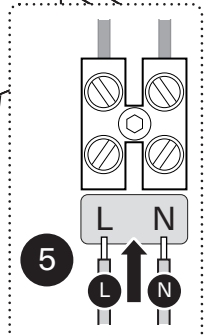
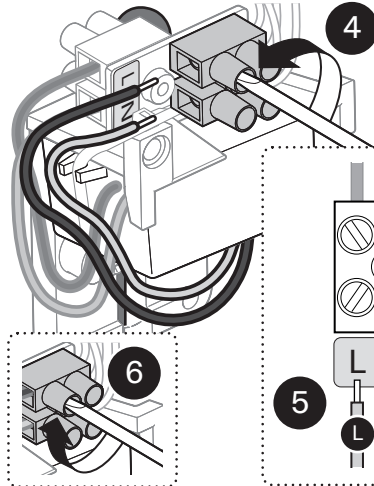
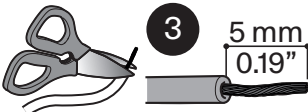
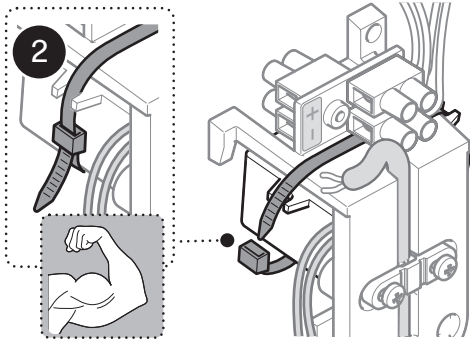
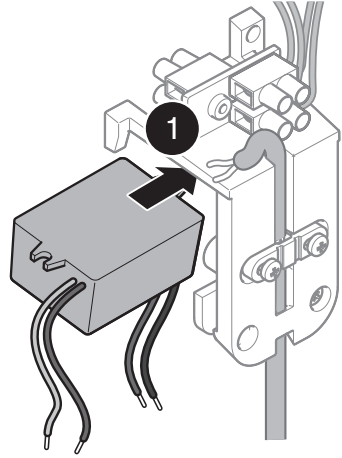
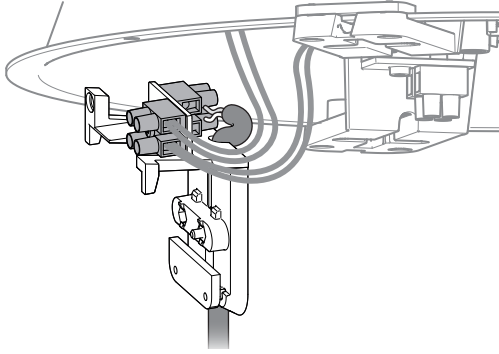

5 LIGHTS ROUND SMALL	MAX 5
5 LIGHTS ROUND LARGE	MAX 5
9 LIGHTS ROUND SMALL	MAX 8
9 LIGHTS ROUND LARGE	MAX 6
7 LIGHTS OVAL	MAX 7
11 LIGHTS OVAL	MAX 11

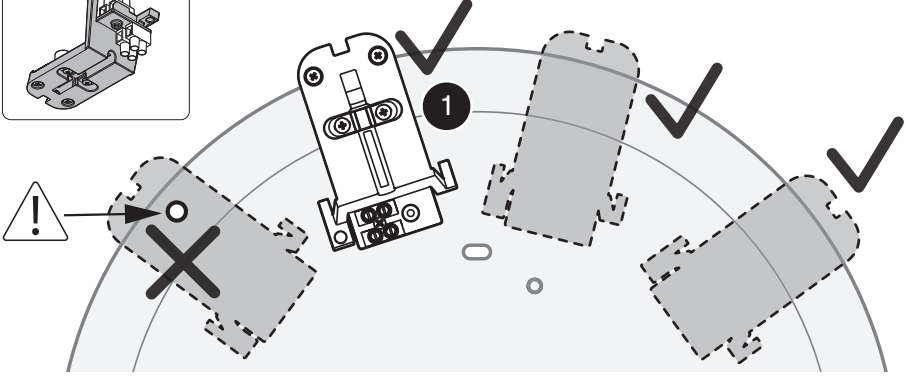
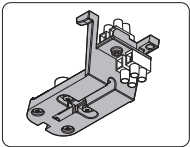
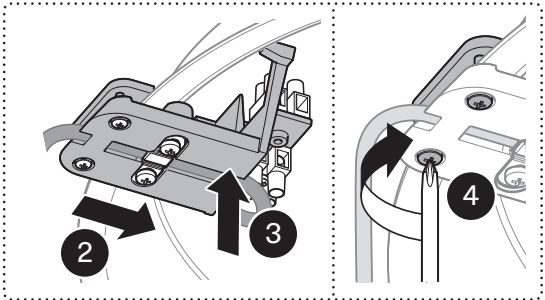

9 LIGHTS ROUND LARGE

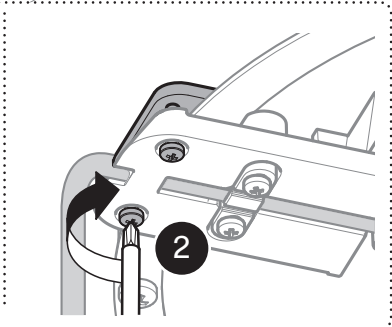
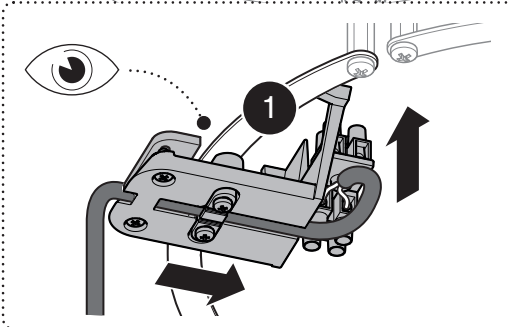
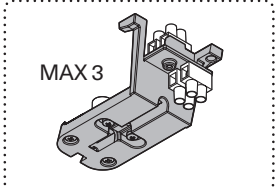
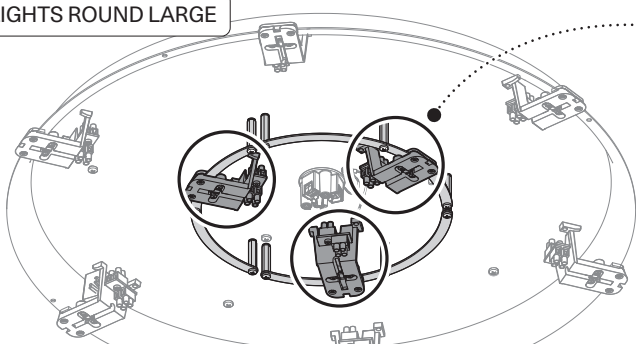

9 LIGHTS ROUND SMALL

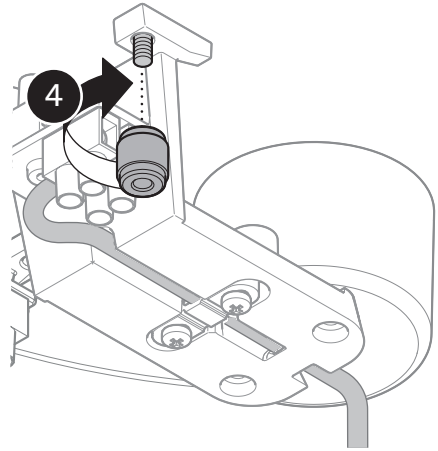
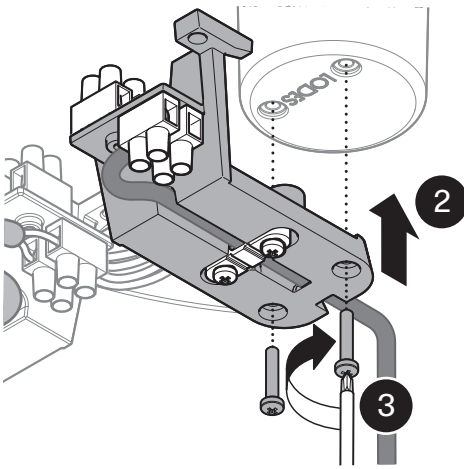
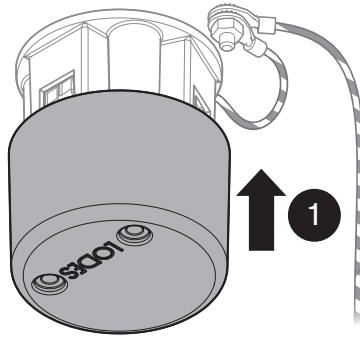

5 LIGHTS ROUND SMALL  
5 LIGHTS ROUND LARGE  
9 LIGHTS ROUND LARGE  
7 LIGHTS OVAL  
11 LIGHTS OVAL

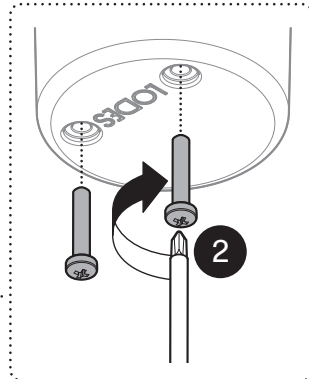
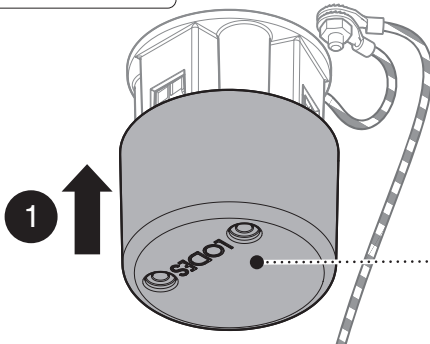

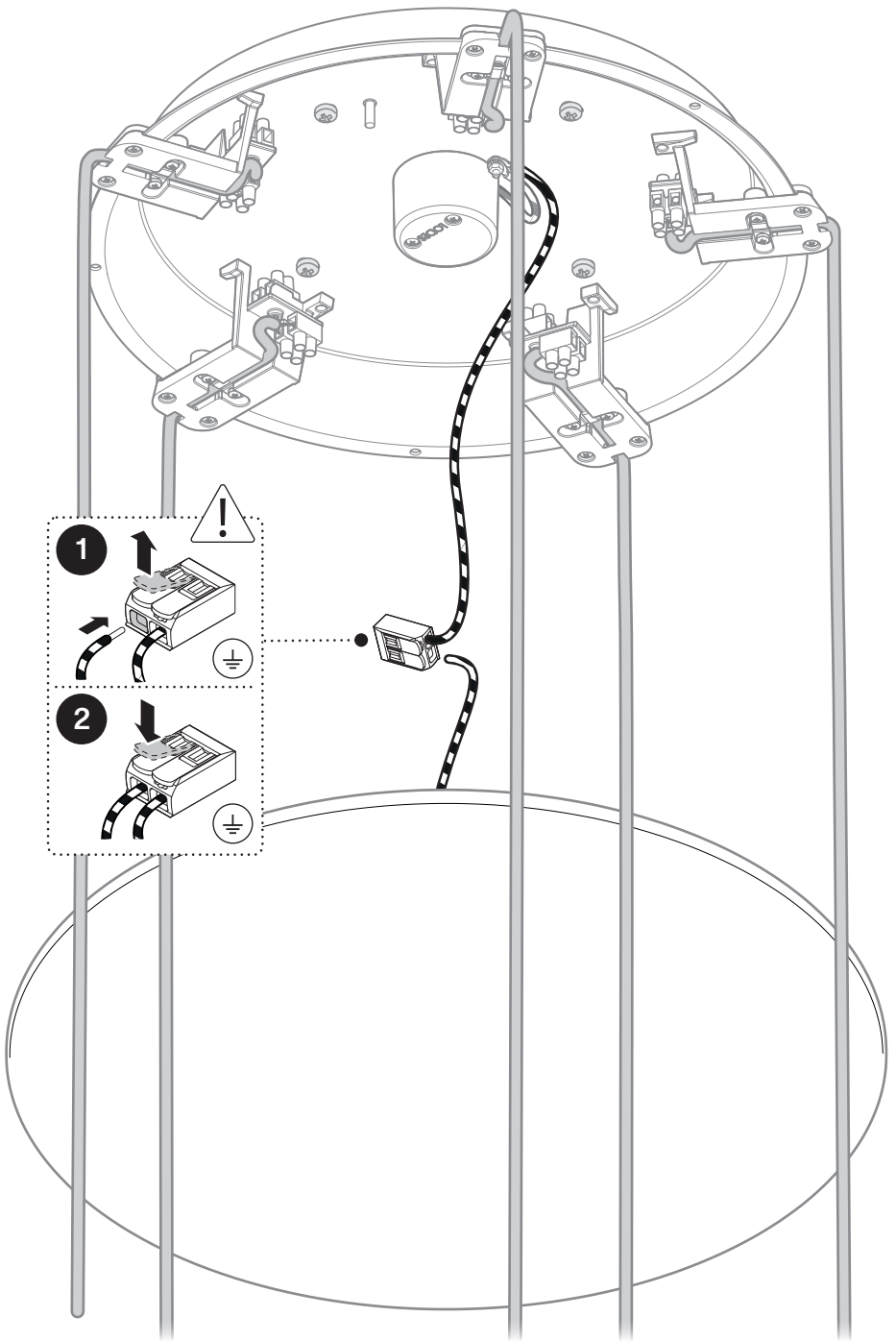

9 LIGHTS ROUND LARGE	x4
9 LIGHTS ROUND SMALL	x3

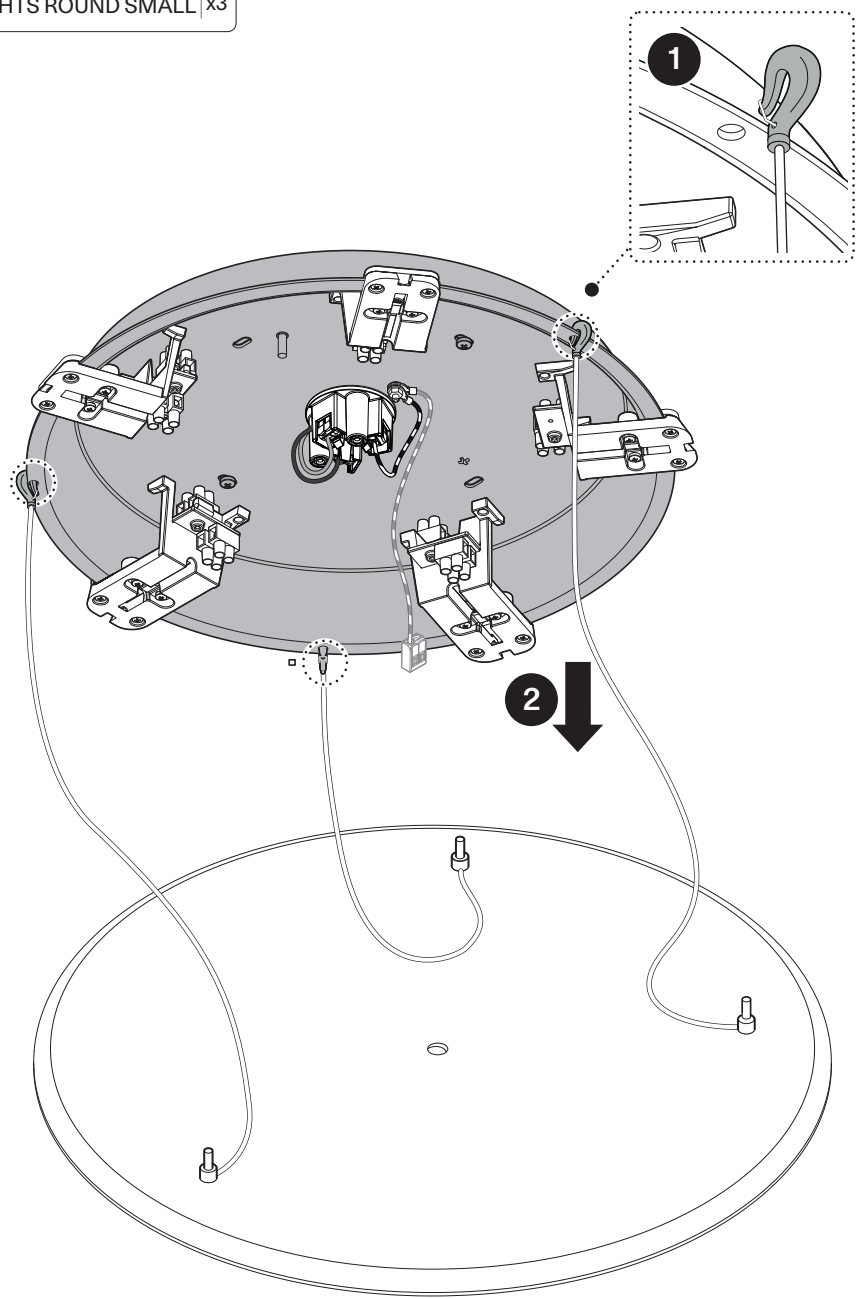

5 LIGHTS ROUND SMALL	x3
5 LIGHTS ROUND LARGE	x3
9 LIGHTS ROUND SMALL	x3
9 LIGHTS ROUND LARGE	x4
7 LIGHTS OVAL	x6
11 LIGHTS OVAL	x8

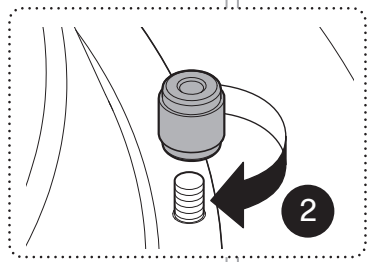
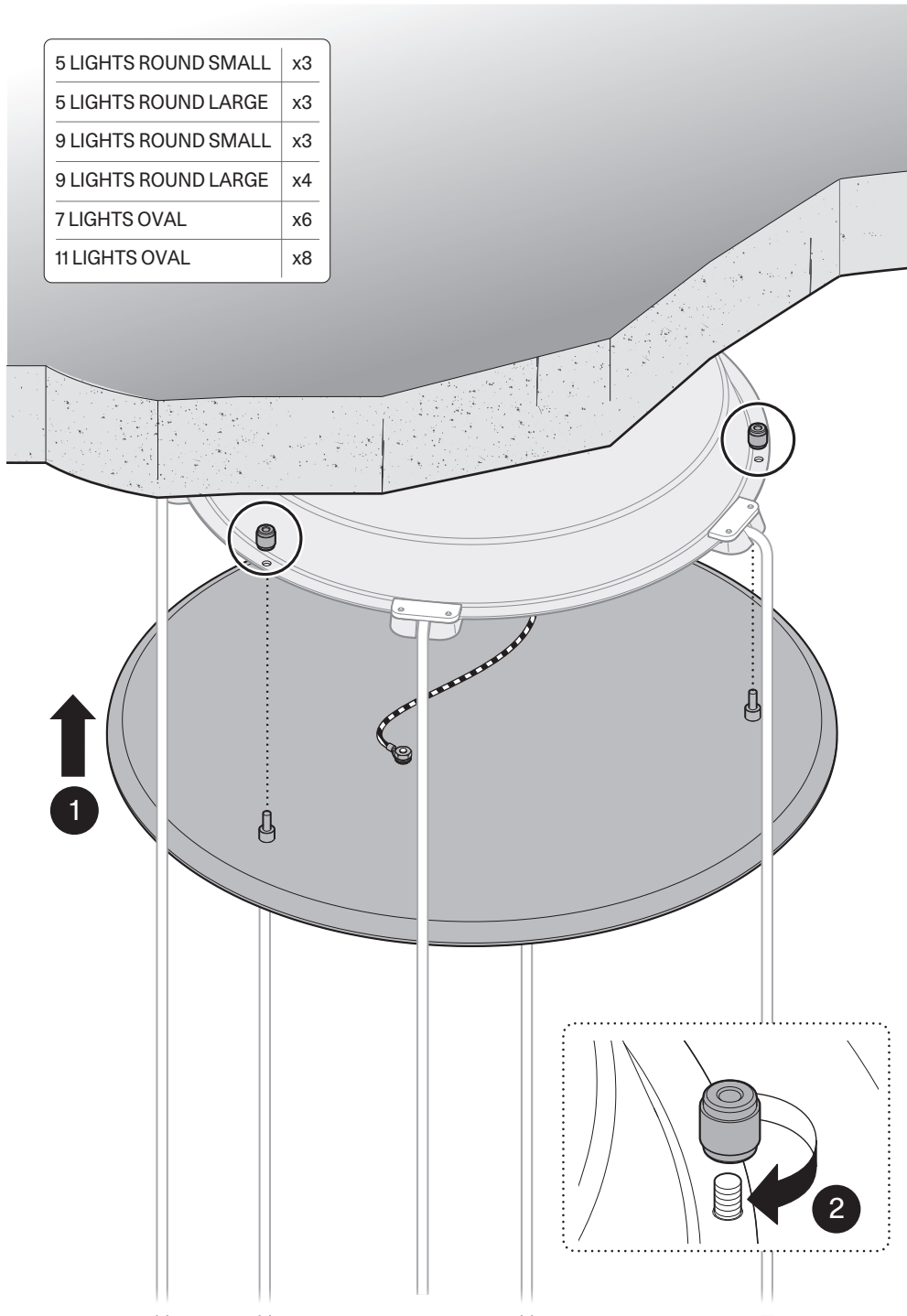

## English

Keep these instructions for future reference. The device must be installed by qualified personnel only.

### ● CAUTION

- ▶ Clean the product using a soft cloth, slightly dampened with soap or detergent, preferably diluted in water. Never use ethyl alcohol or detergents containing even small amounts of acetone, trichloroethylene, ammonia and solvents in general.
- ▶ Fix the device in place using a system that is appropriate for the installation surface.
- ▶ The device must not be installed in positions other than those specified in the assembly instructions.
- ▶ This appliance must only be used indoors. Do not use in damp, saline or aggressive environments.
- ▶ LODES light fixtures and canopies are made, tested and configured to be installed exclusively with one other.

## Italiano

Conservare queste istruzioni per una manutenzione futura. L'apparecchio deve essere installato da personale qualificato.

### ● ATTENZIONE

- ▶ Pulire il prodotto con un panno morbido leggermente inumidito di sapone o detersivi liquidi neutri, meglio se diluiti in acqua. Evitare assolutamente l'uso di alcool etilico o di detersivi contenenti anche in piccole quantità acetone, trielina, ammoniaca e solventi in generale.
- ▶ Fissare l'apparecchio utilizzando un sistema idoneo alla superficie di montaggio.
- ▶ L'apparecchio non deve

essere installato in posizioni diverse da quelle indicate nelle istruzioni di montaggio.

- ▶ Questo apparecchio deve essere utilizzato solo in ambienti interni; non utilizzare in ambienti umidi, salini o aggressivi.
- ▶ Gli apparecchi e i rosoni Lodes sono stati realizzati, testati e conformati per essere installati esclusivamente gli uni con gli altri.

## Français

Conservez ces instructions pour une maintenance future. L'appareil doit être installé par un personnel qualifié.

### ● ATTENTION

- ▶ Nettoyez le produit avec un chiffon doux, légèrement imbibé de savon ou de détergent, préféablement dilués dans de l'eau. Évitez absolument d'utiliser de l'alcool éthylique ou de détergents contenant même de petites quantités d'acétone, de trichloréthylène, d'ammoniac et de solvants en général.
- ▶ Fixer le luminaire en utilisant un système approprié à la surface de montage.
- ▶ L'appareil ne doit pas être installé dans des positions autres que celles indiquées dans les instructions de montage.
- ▶ Cet appareil doit être utilisé uniquement en intérieur ; ne pas l'utiliser dans des environnements humides, salins ou agressifs.
- ▶ Les appareils et les patères Lodes ont été réalisés, testés et conformés pour être installés exclusivement les uns avec les autres.

## Deutsch

Bewahren Sie diese Anweisungen zum späteren

Nachschlagen auf. Nur von einem qualifizierten Elektrofachmann installieren lassen.

### ● ACHTUNG

- ▶ Reinigen Sie das Produkt mit einem weichen Tuch, das leicht mit Seife oder Reinigungsmittel angefeuchtet ist. Verwenden Sie niemals Alkohol oder Reinigungsmittel, die auch nur geringe Mengen an Aceton, Trichlorethylen, Ammoniak oder Lösungsmitteln enthalten.
- ▶ Das Gerät mit einem für die Montagefläche geeigneten System befestigen.
- ▶ Das Gerät darf nicht in anderen als den in der Montageanleitung angegebenen Positionen installiert werden.
- ▶ Dieses Gerät darf nur in Innenbereichen verwendet werden. Nicht in feuchten, salzhaltigen oder aggressiven Umgebungen einsetzen.
- ▶ Die Lodes Geräte und Baldachine sind so gefertigt, geprüft und angeglichen, dass sie ausschließlich miteinander installiert werden können.

## Español

Conserve estas instrucciones para un futuro mantenimiento. El aparato debe ser instalado solo por personal cualificado.

### ● ATENCIÓN

- ▶ Limpie el producto con un paño suave, ligeramente humedecido con jabón o detergentes líquidos neutros, mejor si están diluidos en agua. Nunca use alcohol etílico o detergentes que contengan incluso pequeñas cantidades de acetona, tricloroetileno, amoniaco y solventes en general.
- ▶ Fijar el aparato utilizando un sistema idóneo en la

superficie de montaje.

► El aparato no se debe instalar en otras posiciones que no sean las que se indican en las instrucciones de instalación.

► Este aparato sólo se debe utilizar en interiores; no lo utilice en ambientes húmedos, salinos o agresivos.

► Los aparatos y los florones Lode se han realizado, testado y ajustado para ser instalados exclusivamente unos con otros.

## Русский

Храните эти инструкции для дальнейшего использования.

Для установки только квалифицированным электриком.

### ● ВНИМАНИЕ

► Выполните очистку продукта с помощью мягкой ткани, слегка смоченной мылом или моющим средством, разбавленным водой. Никогда не используйте этиловый спирт или моющие средства, содержащие даже небольшие количества ацетона, трихлорэтилена, аммиака и растворителя.

► Закрепите светильник с применением подходящей системы к монтажной поверхности.

► Запрещается устанавливать изделие в положениях, отличных от указанных в инструкции по монтажу.

► Этот прибор предназначен только для использования в помещении, не использовать его во влажных, агрессивных или содержащих соль помещениях.

► Светильники и крепления Lodes были изготовлены, испытаны и подходят для

установки исключительно друг с другом.

## 繁體中文

請妥善保管本說明書以便將來查閱。應由具備資質的人員安裝此設備。

### ● 請注意

► 用一塊稍稍浸濕皂液或中性清洗劑(最好稀釋)的濕布清潔產品。

禁止使用含有乙醇或含有(包括小劑量)丙酮、三氯乙烯、氨、一般劑的清洗劑。

► 請使用一部適宜系統將照明設備固定於安裝表面上。

► 不得將設備安裝在組裝說明指定位置之外的位置。

► 本設備僅可在室內使用,請勿在潮濕、含鹽或腐蝕性環境中使用。

► Lodes的照明設備和吊燈底座僅為兩者之間的搭配安裝而製造、測試及符合。

## LEGAL SECTION



### Legend of symbols



### EN USER INFORMATION ON RECYCLING WEEE

The WEEE symbol printed on this product indicates that, at the end of its service life, it must not be disposed of as household waste but is intended for separate collection. Contact your local waste collection agency or ask the seller for information about public waste collection centres in your area. Even the seller can collect the old product if you purchase a new one

of the same type. Incorrect disposal may harm people and the environment due to the presence of hazardous substances. Penalties are envisaged for the unlawful disposal of this type of waste.

**IT INFORMATIVA AGLI UTENTI SUL RICICLO RAEE**  
Il simbolo RAEE riportato su questo prodotto indica che quest'ultimo, a fine vita, non deve essere smaltito come rifiuto urbano ma deve essere destinato alla raccolta separata. Per determinare l'ubicazione delle aree pubbliche di raccolta contattare l'ente di raccolta dei rifiuti, o chiedere al venditore. Anche il venditore può ritirare il vecchio prodotto acquistandone uno nuovo dello stesso tipo. Lo smaltimento errato può causare danni alle persone e all'ambiente per la possibile presenza di sostanze pericolose. Sono previste sanzioni in caso di smaltimento abusivo dei suddetti rifiuti.

### FR NOTE D'INFORMATION À L'ATTENTION DES UTILISATEURS SUR E RECYCLAGE - DEEE

Le sigle DEEE utilisé pour ce produit indique qu'il peut être traité comme déchet ménager. L'élimination correcte de ce produit contribuera à la protection de l'environnement. Pour en savoir plus sur le recyclage de ce produit, s'adresser au bureau compétent du lieu de résidence, à la société chargée de l'élimination des déchets ménagers ou au magasin où le produit a été acheté.

### DE RECYCLING-INFORMATIONEN FÜR BENUTZER - WEEE

Das für dieses Produkt verwendete WEEE-Symbol zeigt an, dass dieses nicht als Hausmüll behandelt werden darf. Durch die korrekte Entsorgung des Produktes wird ein Beitrag zum Umweltschutz geleistet. Weitere Informationen zum Recycling dieses Produktes sind bei der örtlichen Stadtverwaltung, dem Hausmüllentsorgungsdienst oder dem Geschäft,

in dem das Produkt gekauft wurde, einzuholen.

### ES NOTA INFORMATIVA PARA LOS USUARIOS SOBRE EL RECICLAJE – RAEE

El símbolo RAEE utilizado para este producto indica que no se puede tratar como residuo doméstico. Eliminar correctamente este producto ayuda a proteger el medio ambiente. Para más información sobre el reciclaje de este producto, diríjase a la oficina de la autoridad local correspondiente, a la empresa encargada de la eliminación de los residuos domésticos o a la tienda donde ha adquirido el producto.

### RU ИНФОРМАЦИЯ ДЛЯ ПОЛЬЗОВАТЕЛЕЙ ПО УТИЛИЗАЦИИ - RAEE

Символ RAEE, используемый для данного изделия, указывает на то, что его нельзя утилизировать как бытовые отходы. Правильная утилизация данного изделия способствует защите окружающей среды. Для получения дополнительной информации об утилизации этого изделия просим обращаться в компетентное учреждение местного административного органа, в компанию, отвечающую за утилизацию бытовых отходов, или в магазин, где было приобретено изделие.

**ZH 致用户的回收信息 RAEE**  
号欧盟指令) 用于本产品的RAEE符号指示本产品不可作为生活垃圾进行处理。妥善处置本产品将有助于环境保护。有关本产品回收的更多信息,请联系当地政府的权威当局、生活垃圾处置公司或购买本产品的商店进行咨询。



EN This certifies that the product complies with the provisions of EC directives.

IT Attesta la conformità del prodotto alle disposizioni delle direttive comunitarie.

FR Atteste la conformité du produit aux dispositions des

directives communautaires.

DE Die Konformität des Produkts mit den Bestimmungen der Gemeinschaftsrichtlinien wird bescheinigt.

ES Certifica la conformidad del producto con las disposiciones de las directivas comunitarias.

RU Удостоверяет соответствие изделия положениям директив Сообщества.

ZH 证明产品符合欧盟指令的规定。



EN Danger of electric shock.

IT Pericolo di scossa elettrica.

FR Risque de secousse électrique.

DE Gefahr eines elektrischen Stromschlags.

ES Peligro de descarga eléctrica.

RU Опасность электрического разряда.

ZH 电击危险。



EN EAC marking confirms the compliance of the goods with the Eurasian Customs Union.

IT EAC è un marchio che attesta la conformità delle merci alle norme dell'Unione doganale euroasiatica.

FR EAC est une marque qui certifie la conformité des marchandises par rapport aux règles de l'Union douanière eurasienne.

DE EAC ist eine Kennzeichnung, die bescheinigt, dass die Waren den Vorschriften der Eurasischen Zollunion entsprechen.

ES EAC es un sello que certifica la conformidad de las mercancías con las normas de la unión aduanera euroasiática.

RU EAC - знак, удостоверяющий

соответствие товаров правилам Евразийского таможенного союза.

ZH EAC是一项证明商品符合欧亚关税同盟规范的标志。



EN Class I device: connection to the yellow / green protective conductor (earth) is compulsory.

IT Apparecchio in Classe I<sup>o</sup>: è obbligatoria la connessione al conduttore di protezione giallo / verde (messa a terra).

FR Appareil en classe I : la connexion au conducteur de protection jaune / vert (mise à la terre) est obligatoire.

DE Gerät der Klasse I: Der Anschluss an den gelb-grünen Schutzleiter (Erdung) ist zwingend erforderlich.

ES Aparato de Clase I: es obligatoria la conexión al conductor de protección amarillo / verde (puesta a tierra).

RU Прибор класса I: необходимо выполнить подключение к желто-зеленому защитному проводу (заземление).

ZH I<sup>o</sup>类设备:必须连接黄色/绿色保护导体(接地线)。

- EN** This product was made using specific processing techniques and treatments, aimed at creating unique results. Any differences between individual items are therefore designed to ensure that every single product is special and unique.
- IT** Questo prodotto è stato realizzato con particolari lavorazioni e trattamenti al fine di ottenere risultati unici. Per tale ragione, eventuali differenze da pezzo a pezzo sono volte a garantire specialità ed unicità ad ogni singolo prodotto.
- FR** Ce produit a été soumis à des ennobissements et des traitements spéciaux pour des résultats uniques. Pour cette raison, les éventuelles différences d'une pièce à l'autre garantissent la particularité et l'unicité de chaque article.
- DE** Dieses Produkt wurde mit speziellen Verfahren und Behandlungen hergestellt, um einzigartige Ergebnisse zu erzielen. Aus diesem Grund sind eventuelle Unterschiede von Teil zu Teil beabsichtigt, um die Besonderheit und Einzigartigkeit jedes Produkts zu gewährleisten.
- ES** Este producto se ha realizado con elaboraciones y tratamientos especiales para conseguir resultados únicos. Por ese motivo las diferencias que pueda haber entre una pieza y otra sirven para garantizar que cada producto es especial y único.
- RU** Данный продукт был реализован с применением особых методов обработки, для получения уникальных результатов. По этим причинам возможные отличия наших изделий гарантируют уникальность и особые характеристики каждого конкретного изделия.
- ZH** 为收获独具特色的效果, 本产品经由特殊工艺和处理制成。因此,每件产品之间可能存在的任何差异均为对单件产品之特殊性和独特性的保证。





## Head offices

Lodes, via Pialoi 32,  
30020 Marcon (Venezia) Italy  
T +39 041 45 69 266  
info@lodes.com

[@lodesbrand](#)



See our collections



## Showrooms

Lodes Paris  
Novaluce S.a.r.l.  
131 Rue du Faubourg  
Saint-Honoré  
75008 Paris, France  
T. +33 142 890 318  
paris@lodes.com

Lodes Doha  
Abensal Lighting  
C-Ring Road, St. 230  
Zone 41, Building no. 245  
Al Hilal – Doha, Qatar  
T. +974 4016 4866  
qatar@abensal.com